

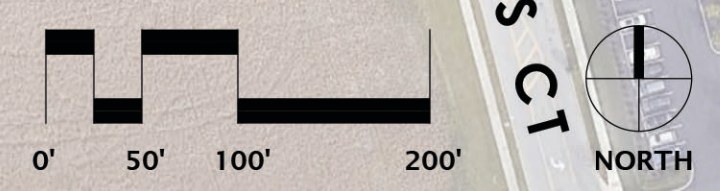

SITE DATA	
GROSS AREA:	+/- 14.4 AC
■ OPEN SPACE:	
REQUIRED:	15%
PROVIDED:	15%





CONCEPT PLAN

THE CRESCENT AT CENTRAL PARK OF GAHANNA

PREPARED FOR CANINI AND ASSOCIATES, LTD.
DATE: 12.16.20

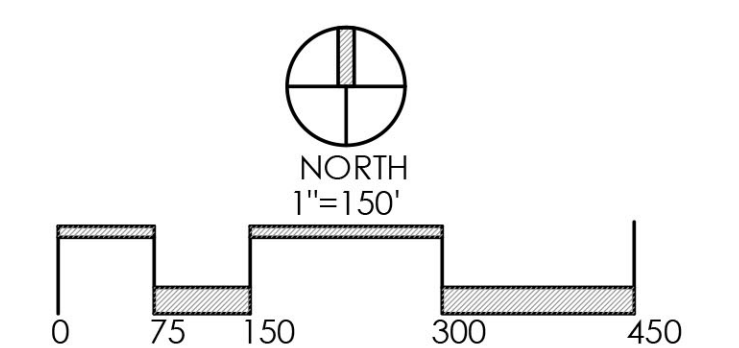

Faris Planning & Design
LAND PLANNING • LANDSCAPE ARCHITECTURE

243 N. 6th Street Suite 401 Columbus, OH 43216
p (614) 487-1944 www.farisplanninganddesign.com

LEGEND

- (A1) 16-UNIT GARDEN APARTMENT
- (A2) 14-UNIT GARDEN APARTMENT
- (A3) 6-UNIT TOWNHOUSE APARTMENT
- (B) CLUBHOUSE
- (C) AMENITY AREA
- (D) DETACHED GARAGES
- (E) RETENTION POND
- (F) GREENWAY CONNECTION
- (G) PARK AMENITY
- (H) PRESERVED TREES
- (I) COMMUNITY ID FEATURE

SITE DATA

GROSS AREA:	+/-14.4 AC.
TOTAL UNITS:	240 DU
1BR UNITS:	92 DU
2BR UNITS:	148 DU
TOTAL PARKING:	502 SPACES
SURFACE:	380 SPACES
GARAGE ATTACHED:	86 SPACES
GARAGE DETACHED:	36 SPACES
*Parking shall not be closer than 8 feet to the front or rear of a main building.	
LOT COVERAGE:	
MAXIMUM ALLOWED:	35%
PROPOSED:	35%
LOT WIDTH:	774 FEET
*The minimum lot width shall be 75 feet plus 2.25 feet for each dwelling unit.	
OPEN SPACE:	
REQUIRED:	15%
PROVIDED:	15%

