

GENERAL LAYOUT NOTES

- BOUNDARY, TOPOGRAPHIC AND UTILITY SURVEY WAS PREPARED BY : V-3 COMPANIES; 3500 SNOUFFER ROAD, SUITE 225, COLUMBUS, OH 43235; (614) 761-1661
- ALL DIMENSIONS ARE TAKEN TO FACE OF CURB OR BUILDING WHERE APPLICABLE UNLESS OTHERWISE NOTED.
- CONTRACTOR SHALL LAYOUT AND ADJUST AS REQUIRED FOR APPROVAL BY LANDSCAPE ARCHITECT PRIOR TO CONSTRUCTION.
- CONTRACTOR SHALL VERIFY DIMENSIONS AND NOTIFY LANDSCAPE ARCHITECT OF ANY DISCREPANCIES.
- BROOM FINISH ON CONCRETE SHALL BE PERPENDICULAR TO TRAFFIC FLOW.
- USE DIMENSIONAL INFORMATION GIVEN. DO NOT SCALE DRAWINGS.
- CONTRACTOR SHALL REFER QUESTIONS ON MATERIALS, FINISHES, LABOR, AND/OR PERFORMANCE STANDARDS NOT SPECIFIED HEREIN TO THE LANDSCAPE ARCHITECT.
- THE LOCATION OF THE EXISTING UNDERGROUND UTILITIES ARE SHOWN IN AN APPROXIMATE WAY ONLY AND HAVE NOT BEEN INDEPENDENTLY VERIFIED BY THE OWNER OR ITS REPRESENTATIVE. THE CONTRACTOR SHALL DETERMINE THE EXACT LOCATION OF ALL EXISTING UTILITIES PRIOR TO COMMENCING WORK AND AGREES TO BE FULLY RESPONSIBLE FOR ANY AND ALL DAMAGES WHICH MIGHT BE OCCASIONED BY THE CONTRACTOR'S FAILURE TO EXACTLY LOCATE AND PRESERVE ANY AND ALL UNDERGROUND UTILITIES.

CONSTRUCTION NOTES

1	LAWN AREA, PROVIDE POSITIVE DRAINAGE ACROSS ALL SURFACES.
2	LANDSCAPE AREA, PROVIDE POSITIVE DRAINAGE ACROSS ALL SURFACES.
3	6' HGT. WOOD FENCE. SEE DETAIL 1, SHEET L-4.
4	EXISTING 4' HGT. 4 RAIL FENCE OFF PROPERTY TO REMAIN.
5	PROPOSED FENCE 4' HGT. 4 RAIL FENCE.

VICINITY MAP

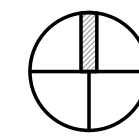
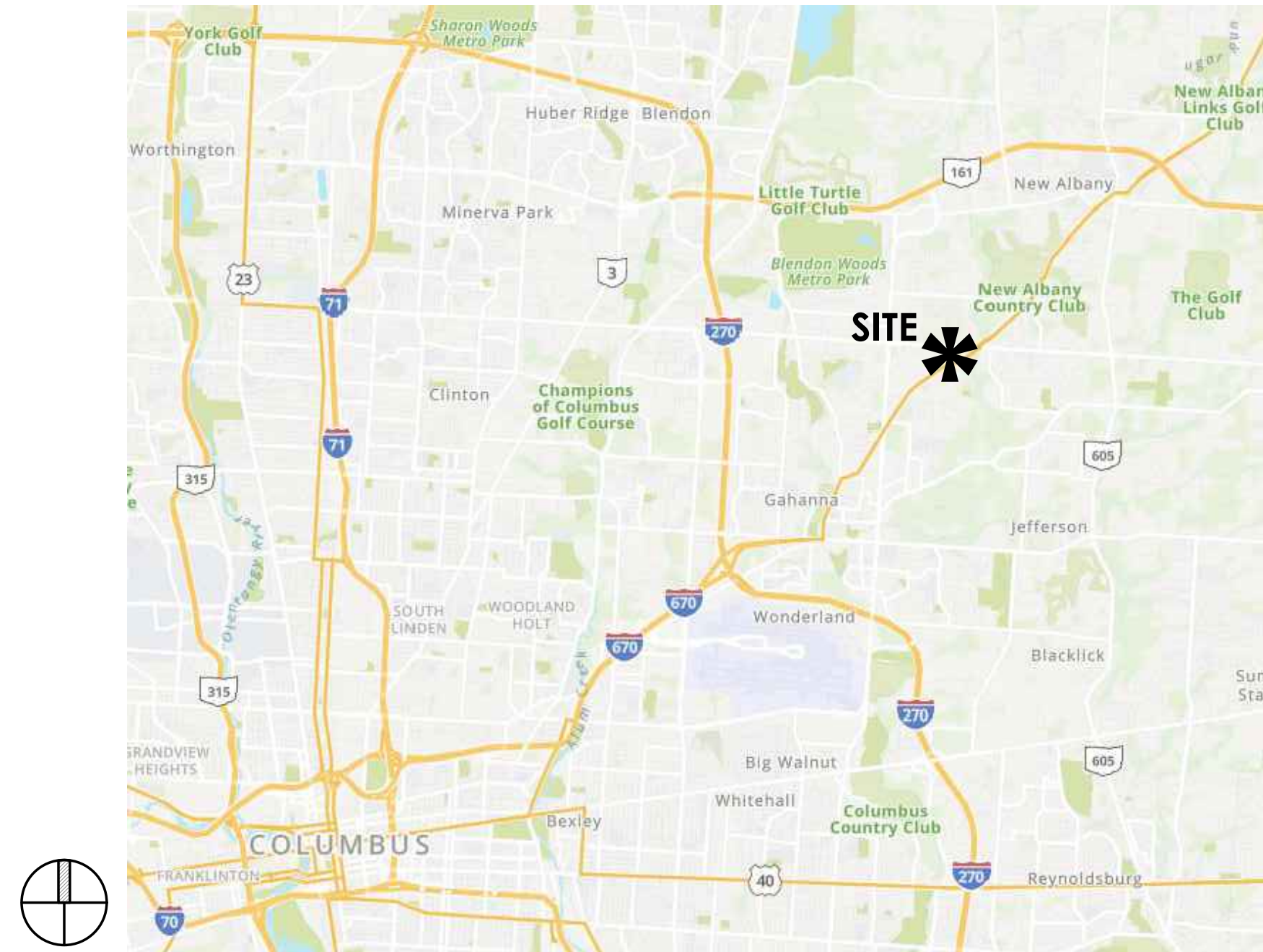

SHEETZ JOHNSTOWN ROAD

GAHANNA, OH

PREPARED FOR

SKILKEN GOLD REAL
ESTATE DEVELOPMENT

4270 MORSE ROAD
COLUMBUS, OH 43230
(614) 342-6632

PREPARED BY

Faris Planning & Design

LAND PLANNING

LANDSCAPE ARCHITECTURE

4876 Cemetery Road
p (614) 487-1964

Hilliard, OH 43026
www.farisplanninganddesign.com



LANDSCAPE REQUIREMENTS

REQUIREMENTS	REQUIRED	PROVIDED
MINIMUM TREES REQUIRED (914.05)		
(A) NEW STRUCTURES, PARKING AREAS, LOADING AREAS, OR OTHER IMPERVIOUS SURFACES SHALL PLANT A MINIMUM OF ONE SHADE TREE CALIPER INCH PER 1,000 SQUARE FEET OF IMPERVIOUS SURFACE. (B) PROTECTED TREES AND PREFERRED TREE SPECIES THAT ARE PRESERVED ONSITE MAY BE SUBSTITUTED FOR THE REQUIREMENTS ABOVE. (3) PRESERVED TREES THAT ARE PREFERRED TREE SPECIES, WITH A MINIMUM DBH OF 20 INCHES ARE AWARDED TWO CREDITS PER INCH.	±82,171 SF OF IMPERVIOUS SURFACE. 82.2 CAL. INCHES OF SHADE TREE REQUIRED, OR AT LEAST 83" CAL. EXISTING TREES PRESERVED ON SITE.	66" CAL. OF EXISTING TREES PRESERVED ON SITE. 18" CAL. PROVIDED. - 30" MAPLE NOT INCLUDED TOWARD PRESERVED TREES DUE TO BEING WITHIN 10' DISTANCE OF PROPOSED ENTRY DRIVE.
INTERIOR LANDSCAPE REQUIREMENTS (1163.08)		
THE REQUIRED AMOUNT OF INTERIOR LANDSCAPING AREA SHALL BE FIVE PERCENT OF THE TOTAL AREA OF THE PARKING LOT PAVEMENT. (1) TREE PER 100 SQUARE FEET OF REQUIRED LANDSCAPE AREA. THE MINIMUM CALIPER OF SUCH TREES SHALL BE THREE INCHES.	±72,296 SF OF PARKING LOT PAVEMENT. 5% = 3,614.8 SF OF LANDSCAPE AREA & 37 TREES REQUIRED	3,809 SF OF LANDSCAPE AREA & 11 DECIDUOUS TREES PROVIDED AT 3" CAL. VARIANCE TO BE REQUESTED FOR ADDITIONAL 26 TREES
PROPERTY PERIMETER REQUIREMENTS (1167.20)		
ANY RESIDENTIAL ZONE ADJOINING ANY COMMERCIAL ZONE, REQUIRED BUFFER ZONE IS 15 FEET ADJACENT TO ALL COMMON BOUNDARIES EXCEPT STREET FRONTAGE AND SHALL INCLUDE ONE TREE FOR EACH 40 FEET OF LINEAR BOUNDARY, OR FRACTION THEREOF, AND A CONTINUOUS SIX FOOT HIGH PLANTING, HEDGE, FENCE, WALL OR EARTH MOUND.	±367 LF OF BOUNDARY. 1 TREE PER 40 LF AND 6' HIGH PLANTING, HEDGE, FENCE OR WALL.	10 EVERGREEN TREES @ 6' HGT. & A 6' HIGH FENCE.

LANDSCAPE PACKAGE CONTENTS

- L-1 OVERALL LANDSCAPE PLAN
- L-2 LANDSCAPE ENLARGEMENTS
- L-3 TREE PRESERVATION PLAN
- SD-1 SITE DETAILS

SUBMISSION DATE:
02/24/23

REVISIONS:

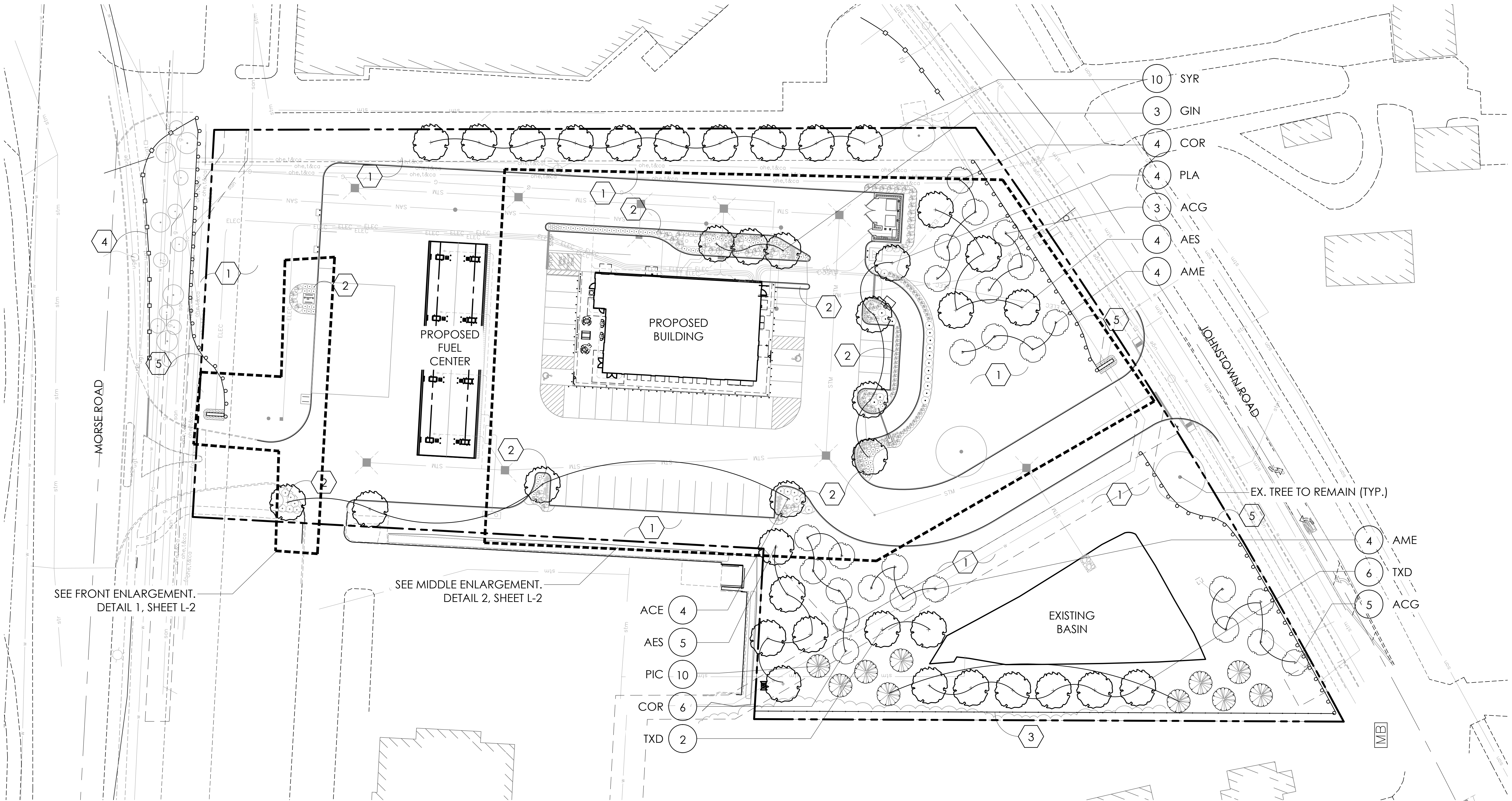

PLANT LIST

(CONTRACTOR RESPONSIBLE FOR ALL PLANTS SHOWN ON PLAN)

QTY	KEY	BOTANICAL NAME	COMMON NAME	SIZE	COND.	REMARKS
TREES						
4	ACE	ACER MIYABEI 'STATE STREET'	STATE STREET MAPLE	3" CAL.	B&B	
8	ACG	ACER GRISEUM	PAPERBARK MAPLE	7-8' HGT.	B&B	3 STEM MIN.
9	AES	AESCULUS OCTANDRA	YELLOW BUCKEYE	2" CAL.	B&B	
8	AME	AMELANCHIER X GRANDIFLORA 'AUTUMN BRILLIANCE'	AUTUMN BRILLIANCE SERVICEBERRY	7-8' HGT.	B&B	3 STEM MIN.
10	COR	CORNUS KOUSA 'MILKY WAY'	MILKY WAY DOGWOOD	7-8' HGT.	B&B	
3	GIN	GINKGO BILOBA 'AUTUMN GOLD'	AUTUMN GOLD MAIDENHAIR TREE	3" CAL.	B&B	
10	PIC	PICEA ABIES	NORWAY SPRUCE	6' HGT.	B&B	
4	PLA	PLATANUS ACERFOLIA 'EXCLAMATION'	EXCLAMATION LONDON PLANE TREE	3" CAL.	B&B	
10	SYR	SYRINGA RETICULATA 'SNOWDANCE'	SNOWDANCE JAPANESE TREE LILAC	2" CAL.	B&B	
8	TXD	TAXODIUM DISTICHUM	BALDCYPRESS	2" CAL.	B&B	

NOTE: ANNUALS TO BE PLANTED BY OWNER. NOT IN INITIAL LANDSCAPE COSTS

CONSTRUCTION NOTES

- ① LAWN AREA. PROVIDE POSITIVE DRAINAGE ACROSS ALL SURFACES.
- ② LANDSCAPE AREA. PROVIDE POSITIVE DRAINAGE ACROSS ALL SURFACES.
- ③ 6' HGT. WOOD FENCE. SEE DETAIL 1, SHEET L-4.
- ④ EXISTING 4' HGT. 4 RAIL FENCE OFF PROPERTY TO REMAIN.
- ⑤ PROPOSED FENCE 4' HGT. 4 RAIL FENCE.

PLANT KEY TYPICALS

SEE PLANT LIST FOR SPECIFIC PLANT SPECIES

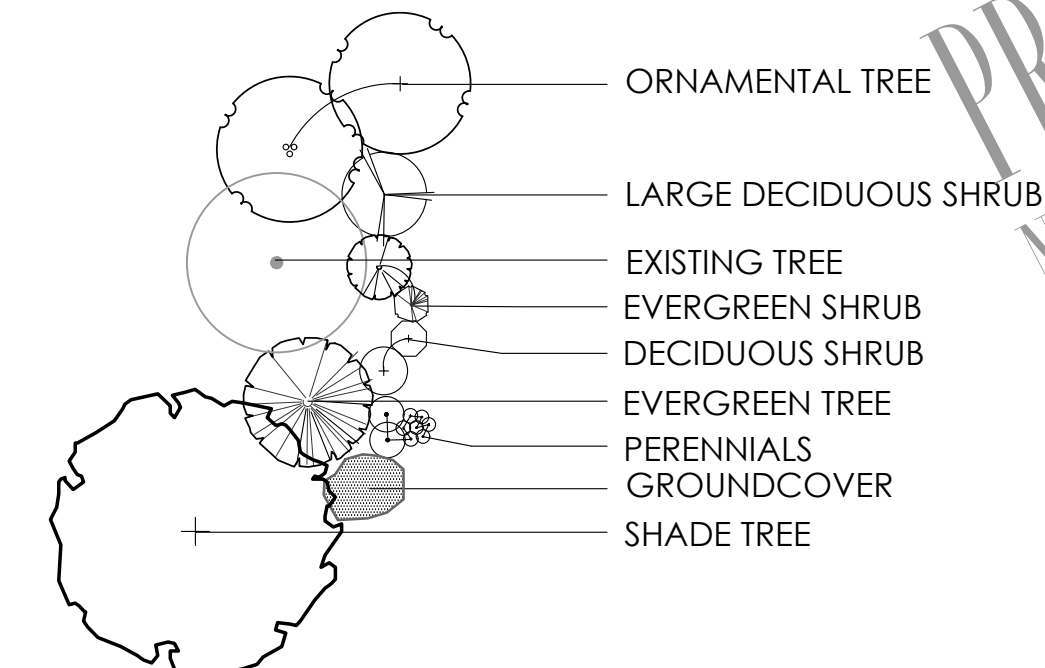

PRELIMINARY
NOT FOR CONSTRUCTION

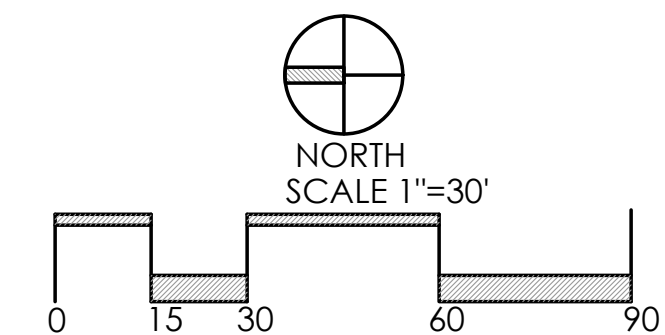

REVISIONS

**OVERALL
LANDSCAPE PLAN**

SHEETZ
JOHNSTOWN ROAD
PREPARED FOR
SKILKEN GOLD REAL ESTATE DEVELOPMENT
4270 MORSE ROAD
COLUMBUS, OH 43230
(614) 342-6632

Paris Planning & Design
LANDSCAPE ARCHITECTURE
Hilliard, OH 43026
www.parisplanninganddesign.com
4876 Cemetery Road
P (614) 487-1964

DATE	02/24/23
PROJECT	21149
SHEET	

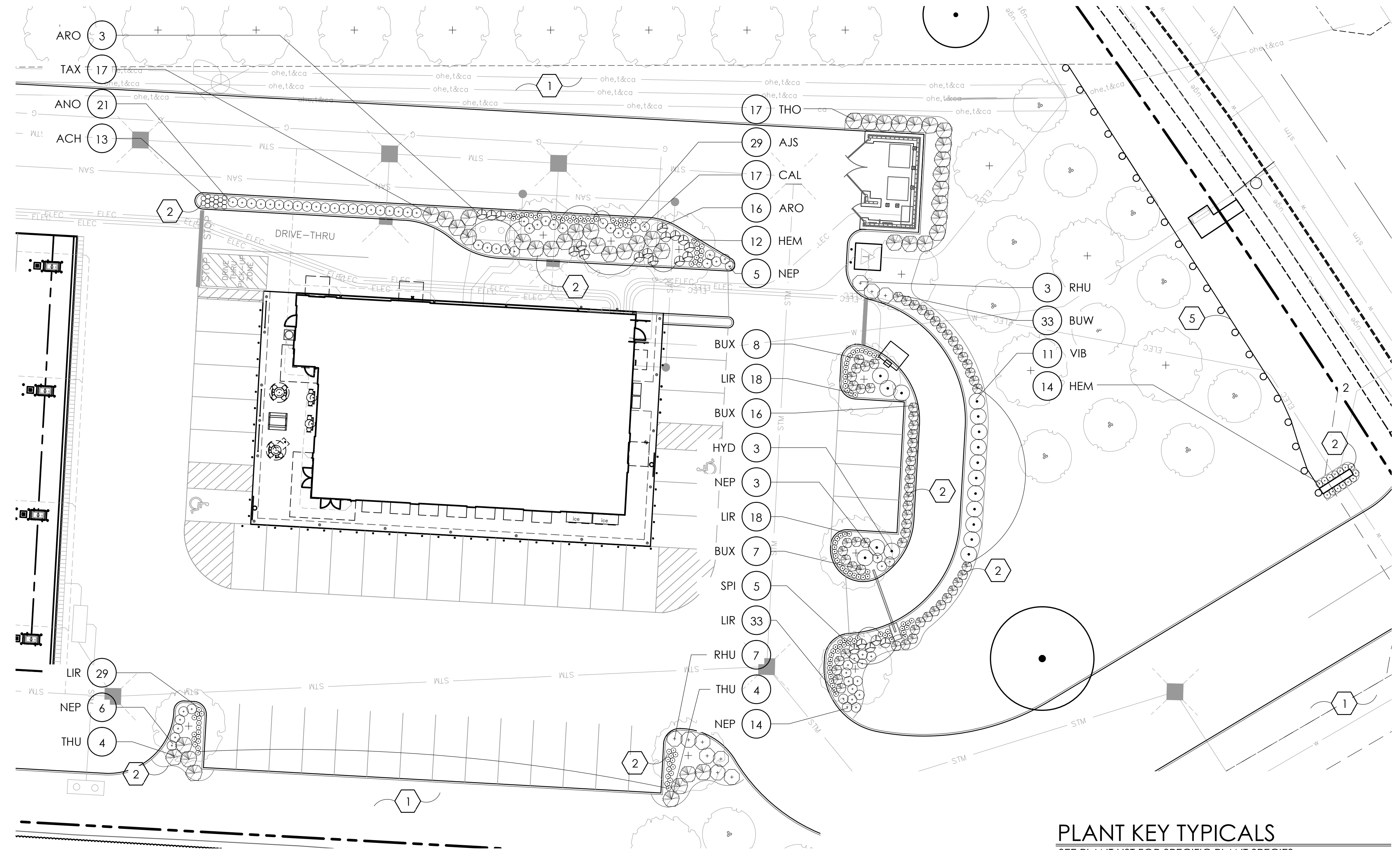
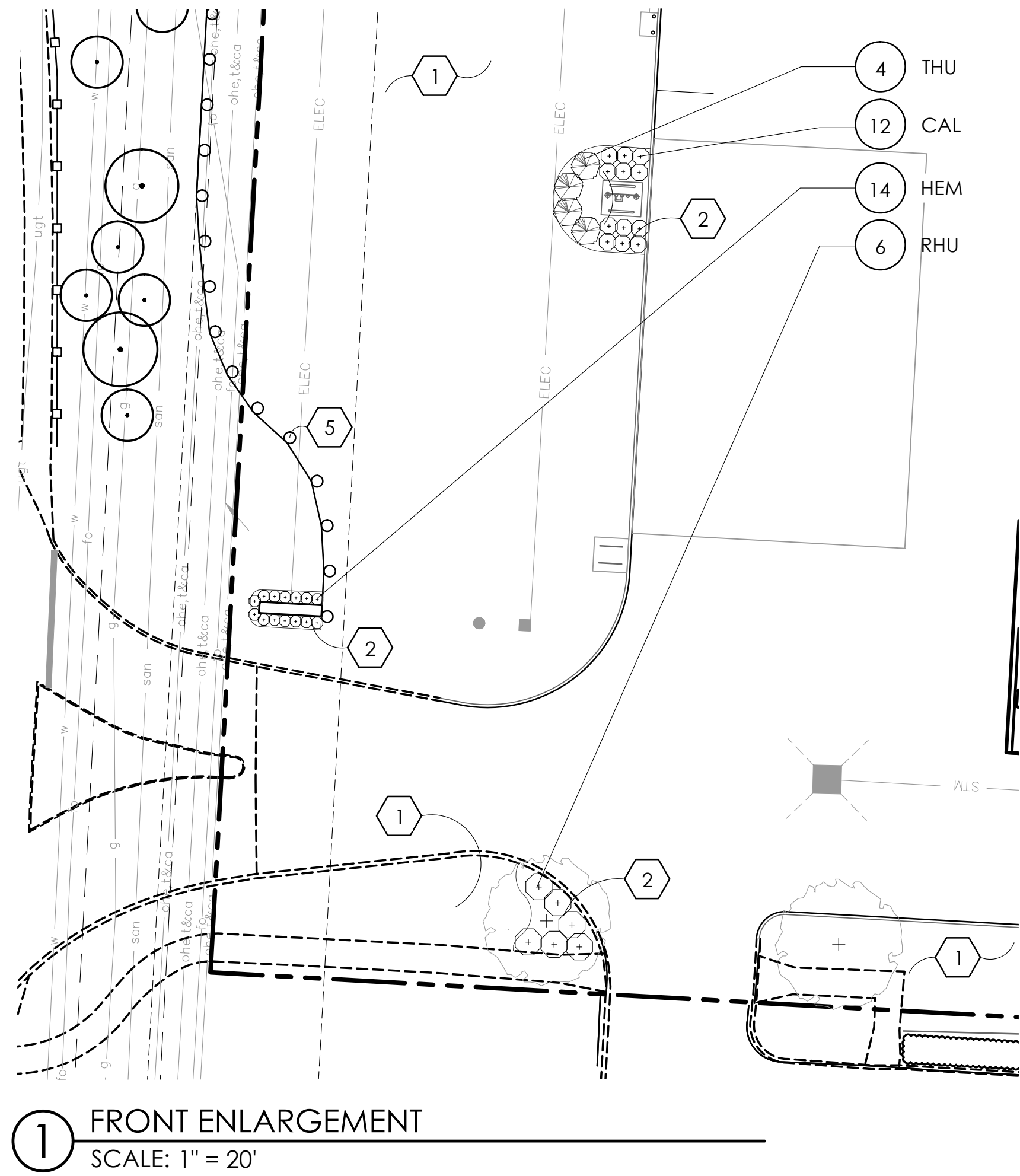

2 MIDDLE ENLARGEMENT
SCALE: 1" = 20"

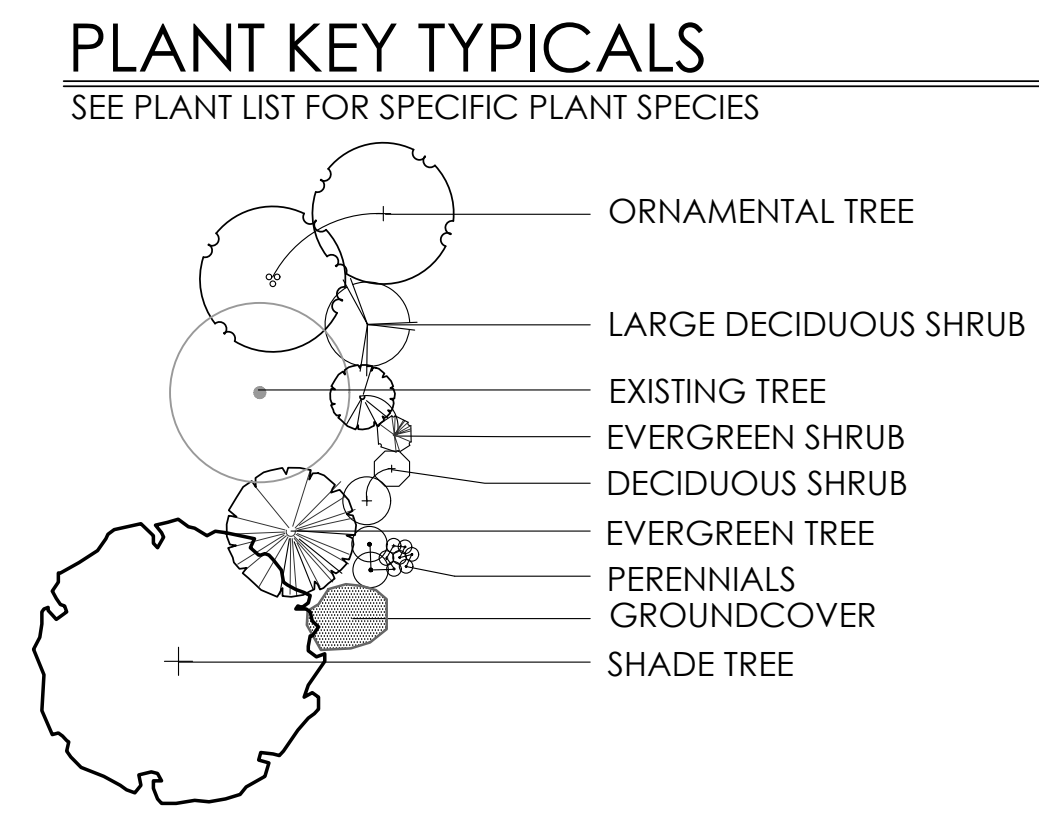

PLANT LIST

(CONTRACTOR RESPONSIBLE FOR ALL PLANTS SHOWN ON PLAN)

QTY	KEY	BOTANICAL NAME	COMMON NAME	SIZE	COND.	REMARKS
SHRUBS						
19	ARO	ARONIA MELANOCARPA 'LOW SCAPE MOUND'	LOW SCAPE MOUND CHOKEBERRY	18" HGT.	B&B	
33	BUW	BUXUS MICROPHYLLA VAR. 'WINTERGEM'	WINTERGEM BOXWOOD	18" HGT.	B&B	
31	BUX	BUXUS X 'GREEN GEM'	GREEN GEM BOXWOOD	18" HGT.	B&B	
3	HYD	HYDRANGEA PANICULATA 'JANE'	LITTLE LIME HYDRANGEA	18" HGT.	B&B	
16	RHU	RHUS AROMATICA 'GRO-LOW'	GROW LOW SUMAC	18" HGT.	B&B	
5	SPI	SPIRAEA 'GOLDMOUND'	GOLDMOUND SPIREA	18" HGT.	B&B	
17	TAX	TAXUS MEDIA HICKSII	HICKSII YEW	18" HGT.	B&B	
17	THO	THUJA OCCIDENTALIS 'SMARAGD'	EMERALD GREEN ARBORVITAE	5' HGT.	B&B	
12	THU	THUJA OCCIDENTALIS 'WOODWARDII'	WOODWARD GLOBE ARBORVITAE	18" HGT.	B&B	
11	VIB	VIBURNUM X JUDDII	JUDDII VIBURNUM	18" HGT.	B&B	
PERENNIALS/ORNAMENTAL GRASSES						
13	ACH	ACHILLEA MILLEFOLIUM 'STRAWBERRY SEDUCTION'	STRAWBERRY SEDUCTION YARROW	NO. 1	CONT.	
29	AJS	SEDUM SPECTABILE 'AUTUMN JOY'	AUTUMN JOY SEDUM	NO. 1	CONT.	
21	ANO	ANDROPOGON GERARDII 'RED OCTOBER'	RED OCTOBER BLUESTEM	NO. 2	CONT.	
29	CAL	CALAMAGROSTIS X ACUTIFLORA 'KARL FOERSTER'	KARL FOERSTER GRASS	NO. 2	CONT.	
40	HEM	HEMEROCALLIS 'HAPPY RETURNS'	HAPPY RETURNS DAYLILY	NO. 1	CONT.	
88	LIR	LIRIOPE MUSCARI 'VARIEGATA'	VARIEGATED LIRIOPE	NO. 1	CONT.	
28	NEP	NEPETA X FAASSENII 'WALKER'S LOW'	WALKER'S LOW CATMINT	NO. 1	CONT.	

NOTE: ANNUALS TO BE PLANTED BY OWNER. NOT IN INITIAL LANDSCAPE COSTS

CONSTRUCTION NOTES

- 1 LAWN AREA, PROVIDE POSITIVE DRAINAGE ACROSS ALL SURFACES.
- 2 LANDSCAPE AREA, PROVIDE POSITIVE DRAINAGE ACROSS ALL SURFACES.
- 3 NOT USED.
- 4 NOT USED.
- 5 PROPOSED FENCE 4' HGT. 4 RAIL FENCE.

PRELIMINARY
NOT FOR CONSTRUCTION

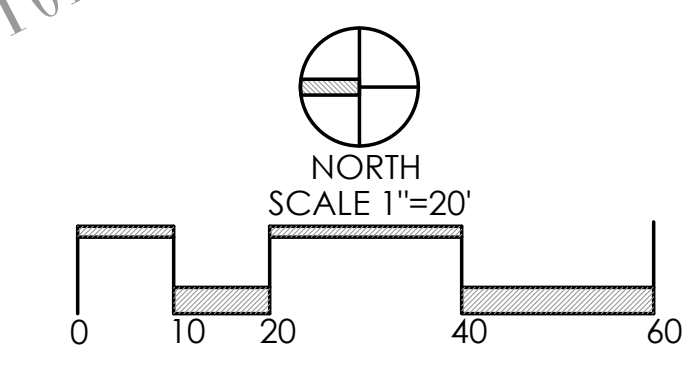

REVISIONS	

LANDSCAPE ENLARGEMENTS

SHEETZ
PREPARED FOR
JOHNSTOWN ROAD
SKILKEN GOLD REAL ESTATE DEVELOPMENT
4270 MORSE ROAD
COLUMBUS, OH 43230
(614) 342-6632

Paris Planning & Design
LANDSCAPE ARCHITECTURE
Hilliard, OH 43026
www.parisplanninganddesign.com
4876 Cemetery Road
P (614) 487-1964

DATE	02/24/23
PROJECT	21149
SHEET	

L-2

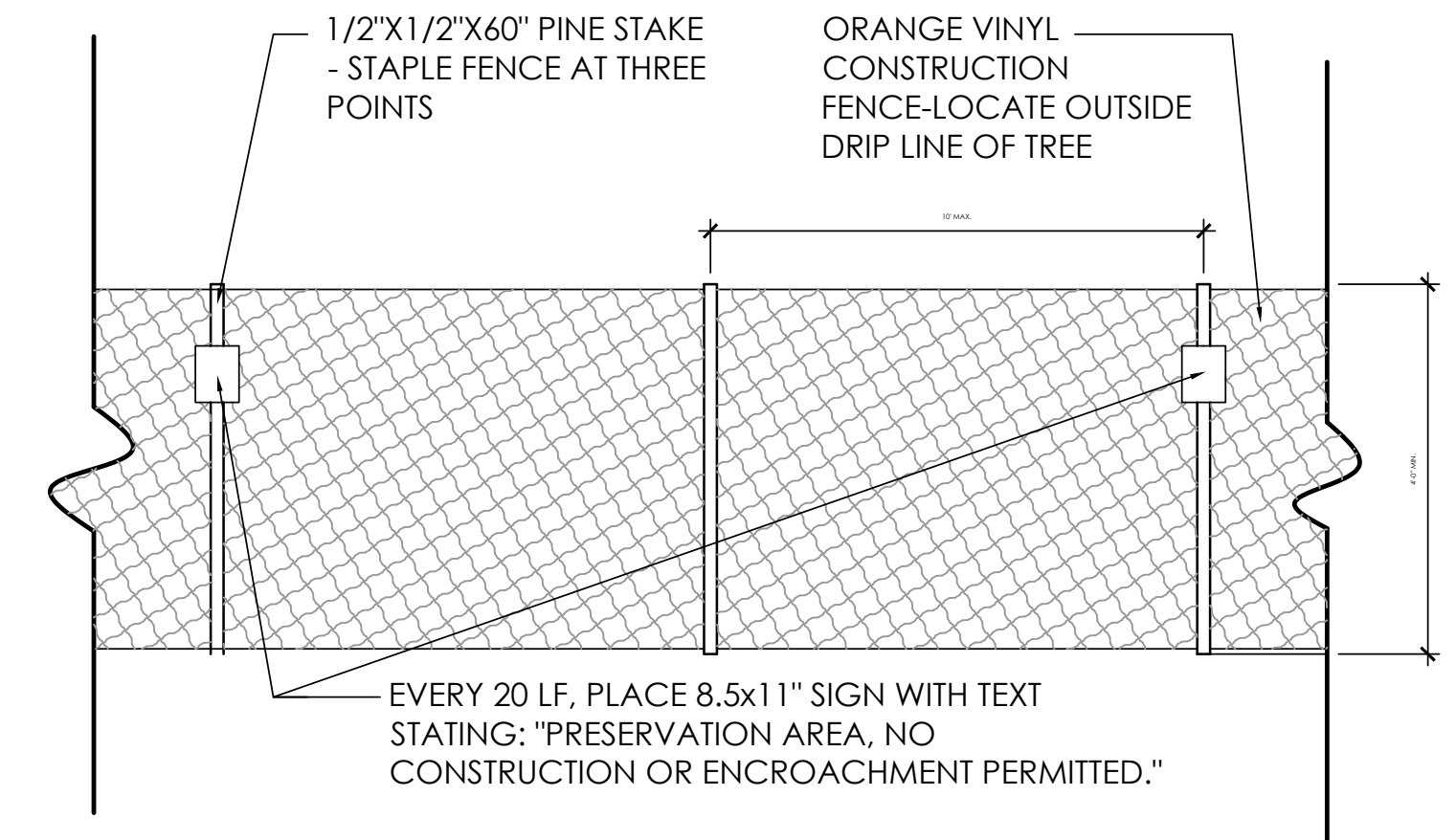
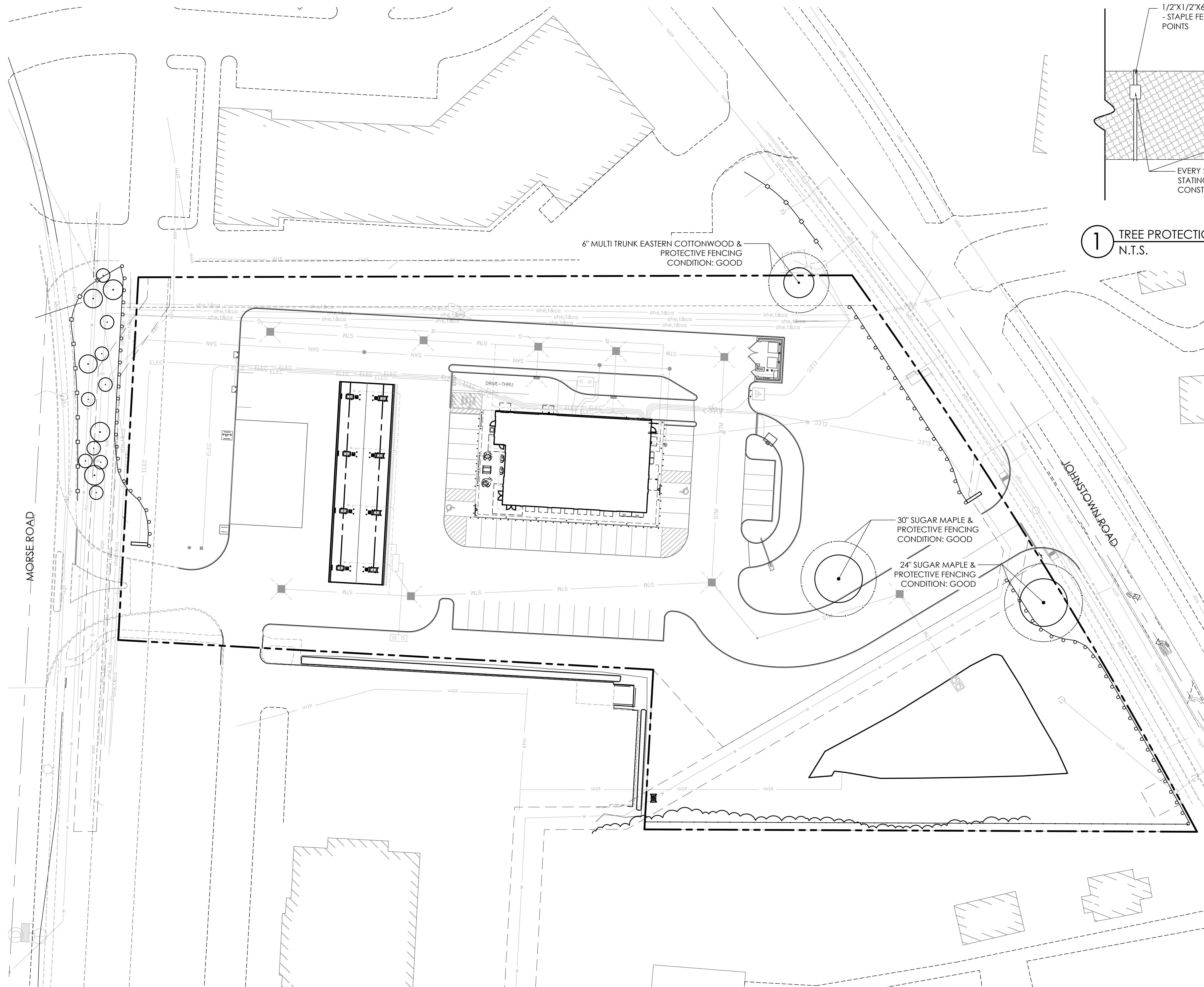

1 TREE PROTECTION FENCE
N.T.S. 05-2809

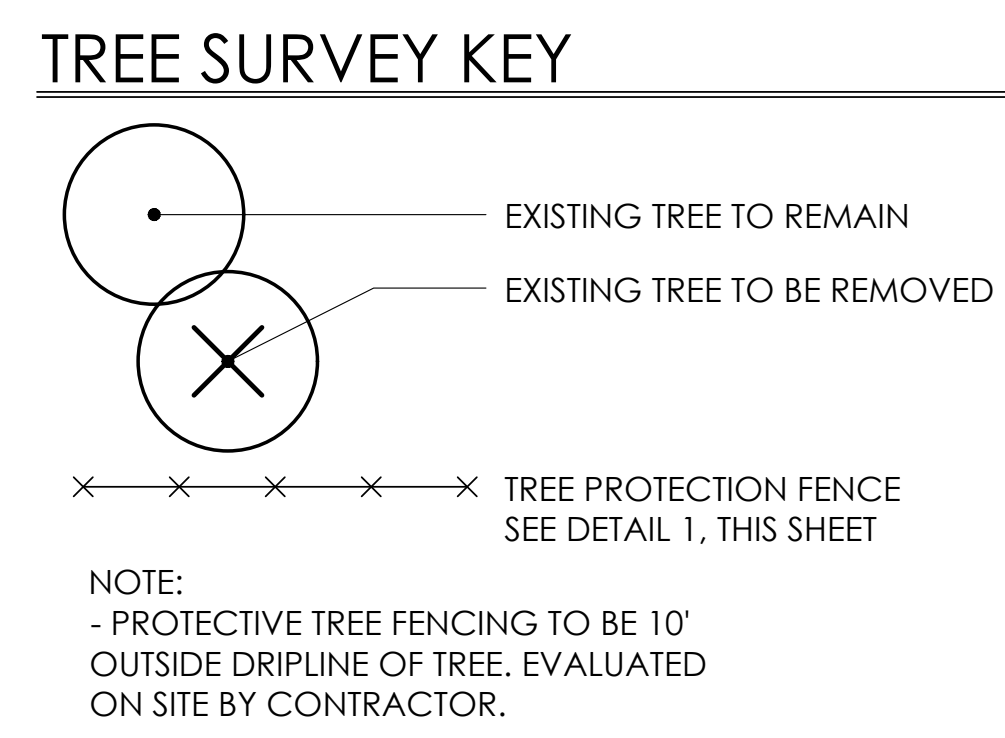

PRELIMINARY
NOT FOR CONSTRUCTION

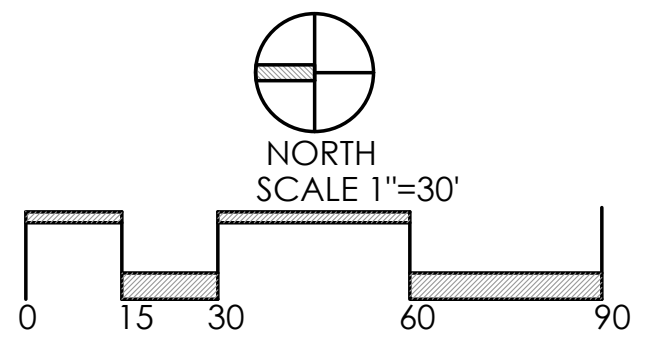

REVISIONS	

**TREE
PRESERVATION
PLAN**

SHEETZ
JOHNSTOWN ROAD
PREPARED FOR
SKILKEN GOLD REAL ESTATE DEVELOPMENT
4270 MORSE ROAD
COLUMBUS, OH 43230
(614) 342-6632

Paris Planning & Design
LANDSCAPE ARCHITECTURE
4876 Cemetery Road
P (614) 487-1964
www.parisplanninganddesign.com
Hilliard, OH 43026
www.crisplanninganddesign.com

DATE	02/24/23
PROJECT	21149
SHEET	

L-3

NOTE:
 -ALL WOOD TO BE PRESSURE TREATED AS APPROVED BY OWNER
 -WOOD SCREWS TO BE FLAT HEAD WEATHER MASTER DACROTIZED STEEL COARSE, THREAD 12x2
 MANUFACTURED BY TEXTRON INC. OR OWNER APPROVED EQUAL
 -ALL WOOD MEMBERS TO BE PAINTED/STAINED TO MATCH FENCE COLOR OF ADJACENT CONDOMINIUM ASSOCIATION TO THE EAST. SUBMIT SAMPLE FOR OWNERS APPROVAL.

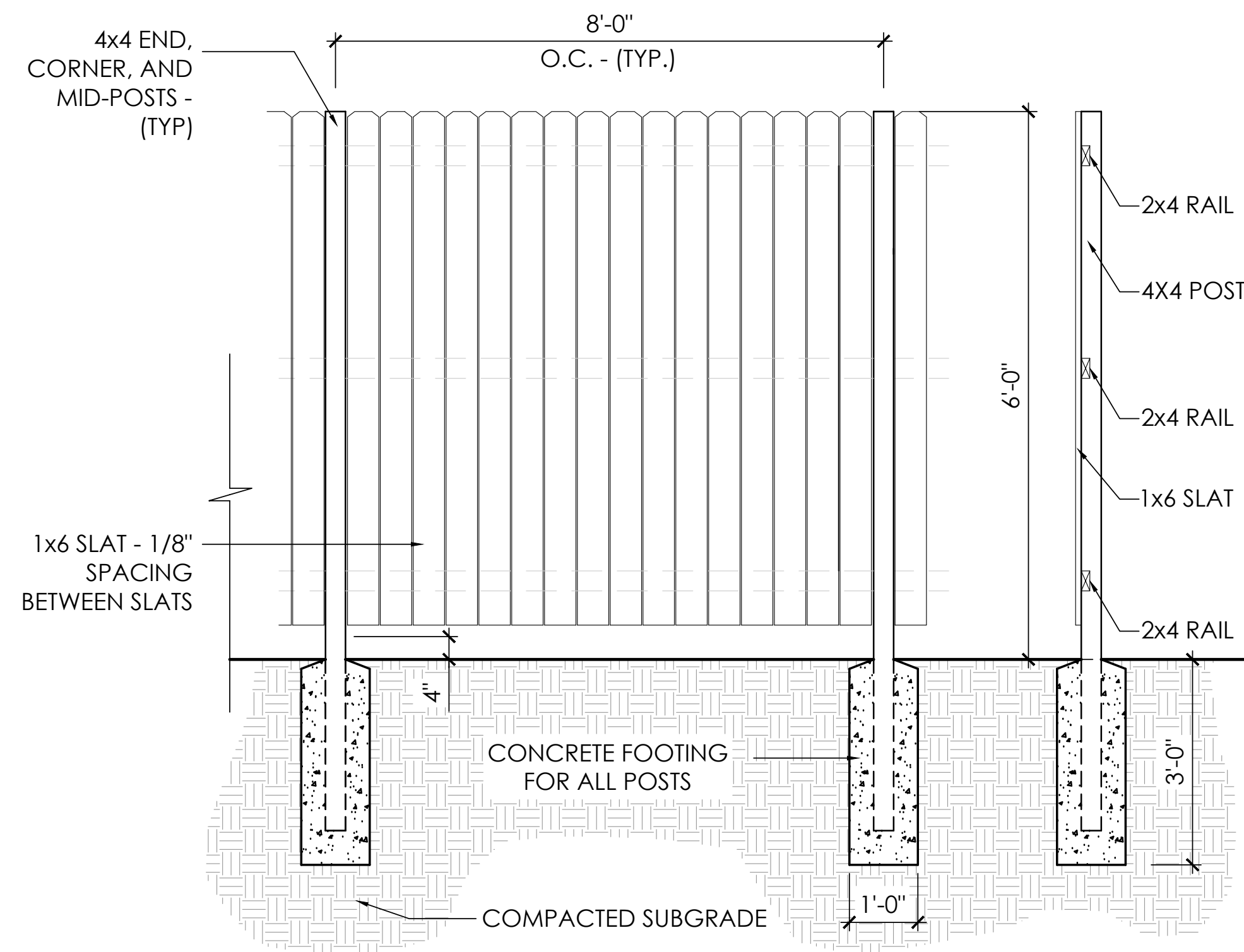

1 6' WOOD PRIVACY FENCE
 N.T.S. 05-1004

NOTE:
 PLANT TREES, SHRUBS, & EVERGREENS AT SAME GRADE AS GROWN IN NURSERY

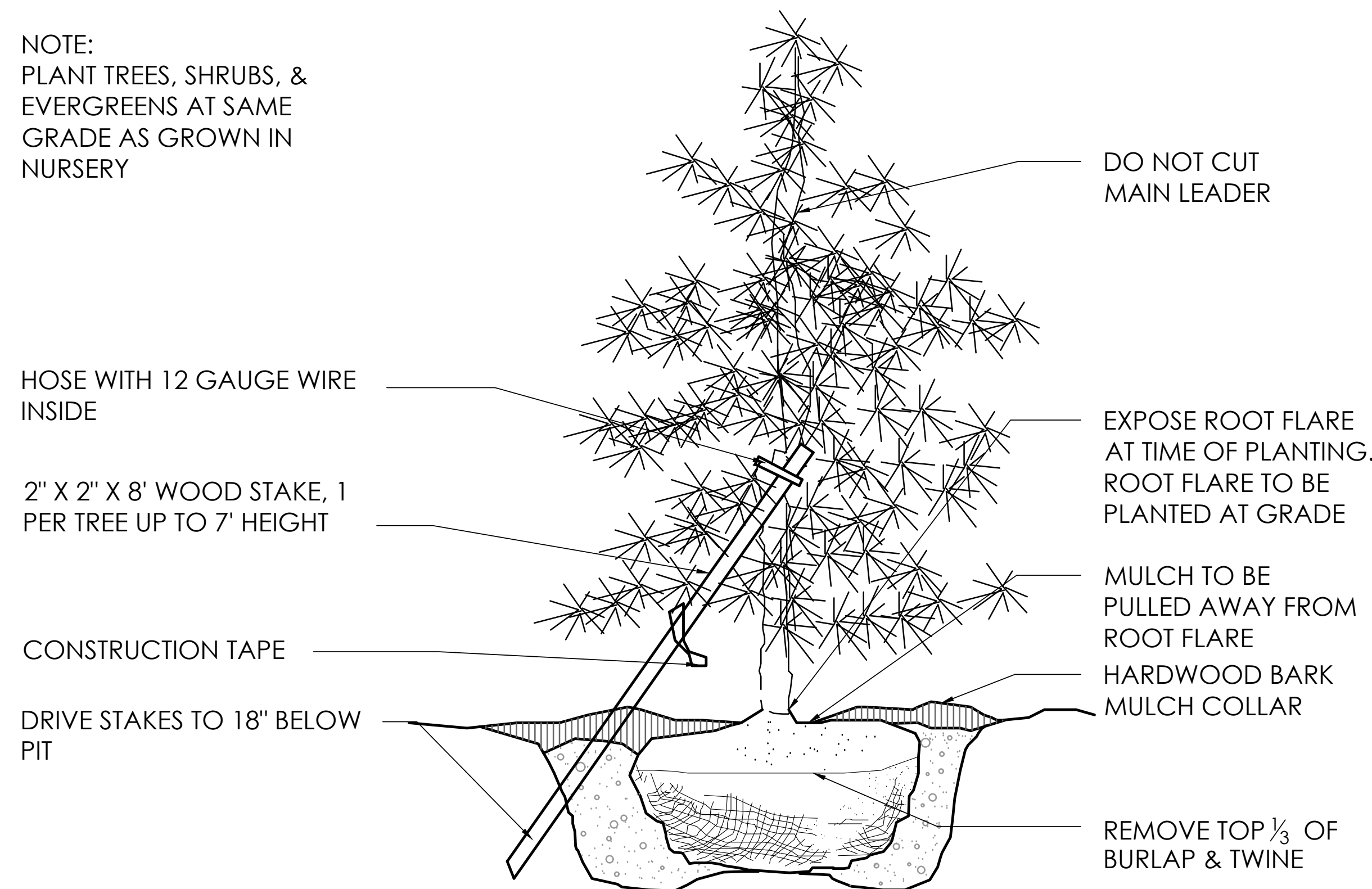

3 EVERGREEN TREE UNDER 7' HGT.
 N.T.S. 01-1100

NOTE:
 THE AMOUNT OF TREE AND SHRUB PRUNING SHALL BE LIMITED TO THE MINIMUM NECESSARY TO REMOVE DEAD OR INJURED TWIGS & BRANCHES, & COMPENSATE FOR THE LOSS OF ROOTS FROM TRANSPLANTING. RETAIN NORMAL SHAPE. PLANT TREES, SHRUBS (EVERGREENS AT SAME GRADE AS GROWN IN NURSERY.

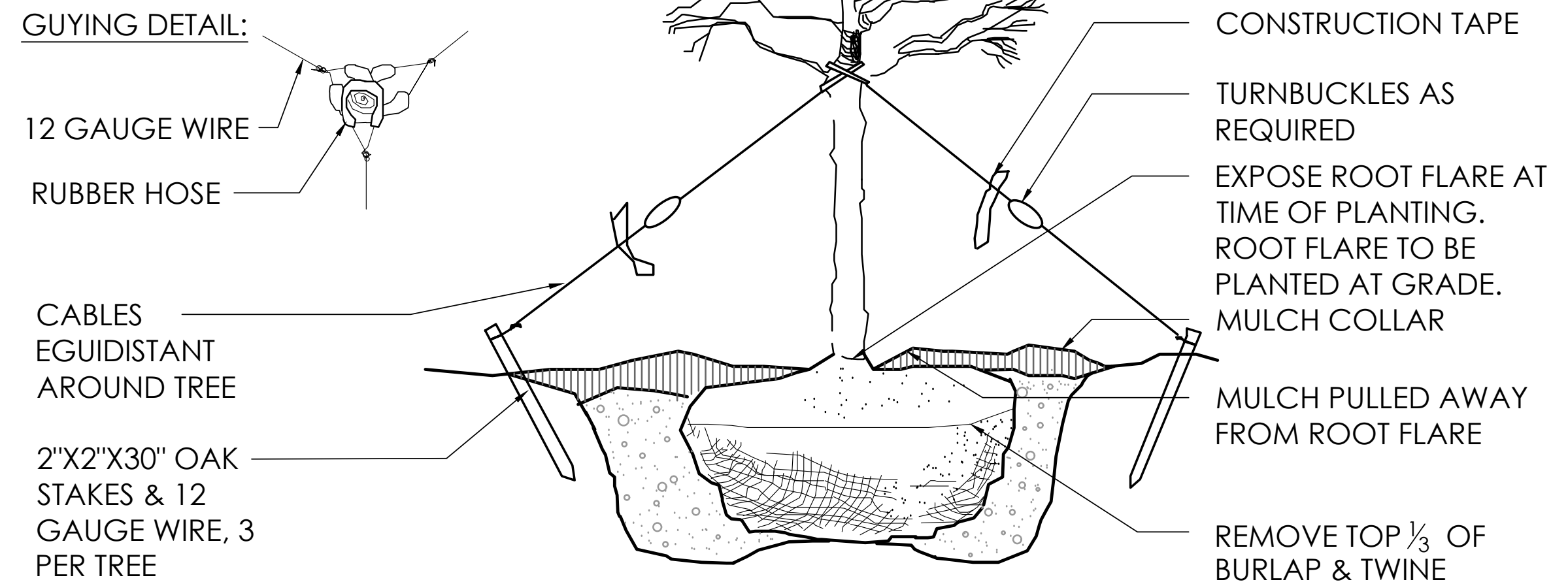

2 DECIDUOUS TREE UNDER 3-1/2" CALIPER
 N.T.S. 01-1001

NOTE:
 THE AMOUNT OF TREE AND SHRUB PRUNING SHALL BE LIMITED TO THE MINIMUM NECESSARY TO REMOVE DEAD OR INJURED TWIGS & BRANCHES. RETAIN NORMAL SHAPE. REMOVE EXCESS SOIL FROM THE TOP OF ROOT MASS. PLANT SHRUBS WITH TOP OF ROOT MASS AT FINISH GRADE.

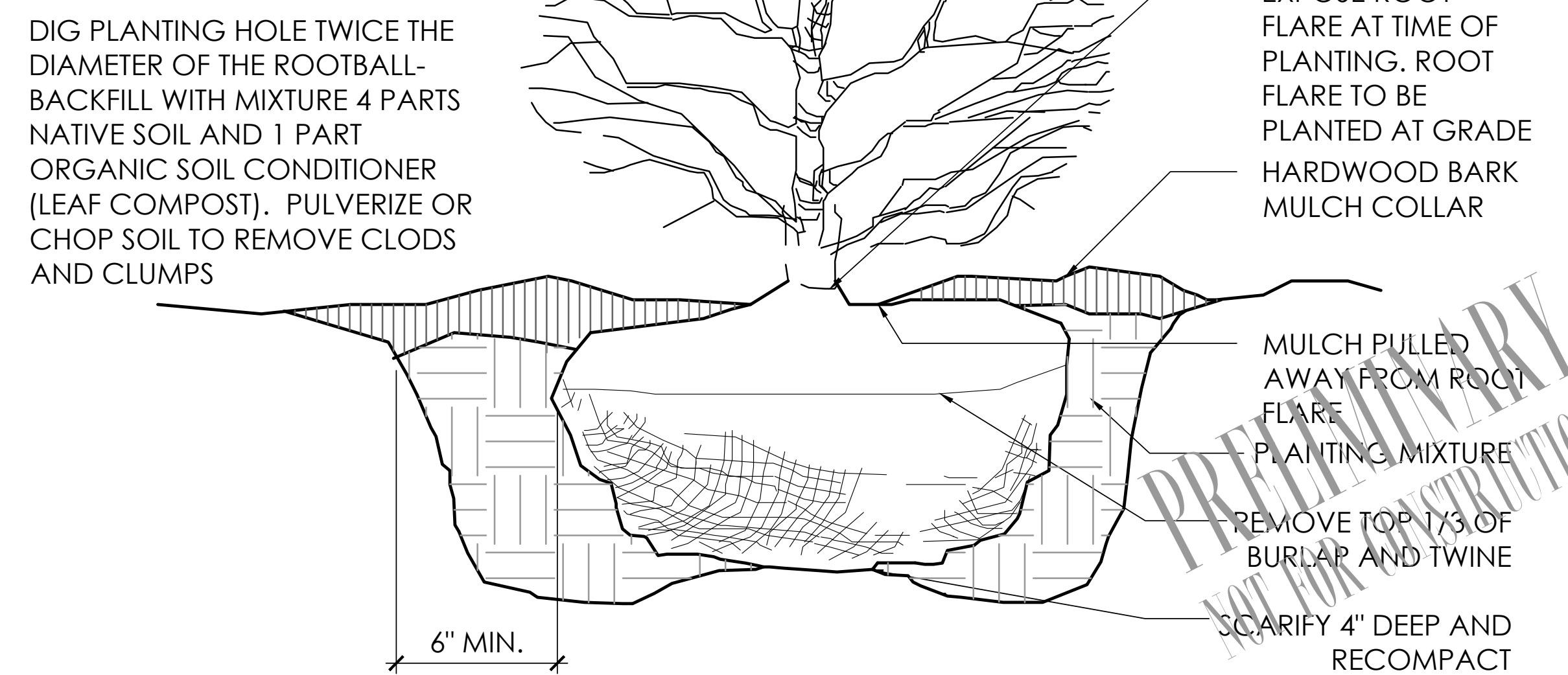

4 SHRUB PLANTING DETAIL
 N.T.S. 01-1300

REVISIONS	

SITE DETAILS

SHEETZ
 PREPARED FOR
JOHNSTOWN ROAD
 SKILKEN GOLD REAL ESTATE DEVELOPMENT
 4270 MORSE ROAD
 COLUMBUS, OH 43230
 (614) 342-6632

Paris Planning & Design
 LANDSCAPE ARCHITECTURE
 Hilliard, OH 43026
 4876 Cemetery Road
 P (614) 487-1964
 www.parisplanninganddesign.com

DATE	02/24/23
PROJECT	21149
SHEET	

SD-1