



Gahanna

**825 Tech Center Dr  
Schematic Design Update**

February 13, 2023

## Project Objectives

- Inviting & Approachable
- Create a Clear Civic Presence
- Community & Service Focused
- Efficient in Planning
- Allow for Future Expansion
- Safe & Secure
- Meets Addition/Renovation SF Goals
- Meets Program Goals
- Building Re-branding/Unique Identity
- Daylight/Quality of Interior Spaces





MORRISON RD

I-270

TECH CENTER DR.

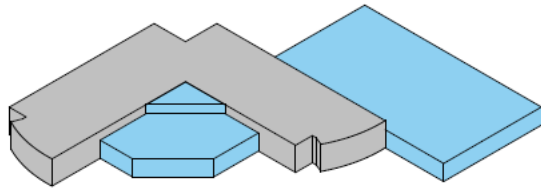

**OPTION 1** ADDITION AT FRONT & BACK

PROJECT OBJECTIVES	
INVITING & APPROACHABLE	●
CREATE A CLEAR CIVIC PRESENCE	●
COMMUNITY & SERVICE FOCUSED	●
DEVELOP INTUATIVE & CLEAR CIRCULATION	⦿
EFFICIENT IN PLANNING	⦿
ALLOW FOR FUTURE EXPANSION	●
SAFE & SECURE	●
MEETS ADDITION / RENOVATION SF GOALS	⦿
MEETS PROGRAM GOALS	●
BUILDING REBRANDING / UNIQUE IDENTITY	●
DAYLIGHTING	⦿

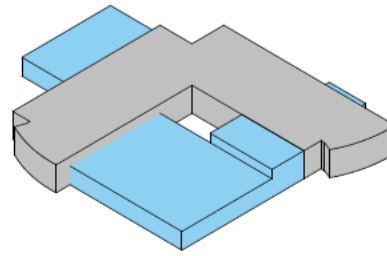

**OPTION 2** ATRIUM

PROJECT OBJECTIVES	
INVITING & APPROACHABLE	●
CREATE A CLEAR CIVIC PRESENCE	●
COMMUNITY & SERVICE FOCUSED	●
DEVELOP INTUATIVE & CLEAR CIRCULATION	●
EFFICIENT IN PLANNING	●
ALLOW FOR FUTURE EXPANSION	○
SAFE & SECURE	●
MEETS ADDITION / RENOVATION SF GOALS	⦿
MEETS PROGRAM GOALS	●
BUILDING REBRANDING / UNIQUE IDENTITY	⦿
DAYLIGHTING	●

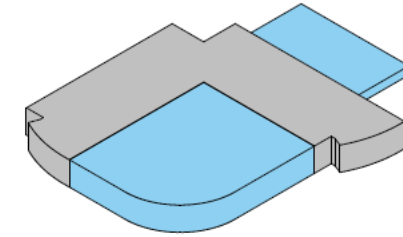

**OPTION 3** INFILL

PROJECT OBJECTIVES	
INVITING & APPROACHABLE	⦿
CREATE A CLEAR CIVIC PRESENCE	●
COMMUNITY & SERVICE FOCUSED	●
DEVELOP INTUATIVE & CLEAR CIRCULATION	⦿
EFFICIENT IN PLANNING	●
ALLOW FOR FUTURE EXPANSION	⦿
SAFE & SECURE	●
MEETS ADDITION / RENOVATION SF GOALS	⦿
MEETS PROGRAM GOALS	●
BUILDING REBRANDING / UNIQUE IDENTITY	●
DAYLIGHTING	⦿

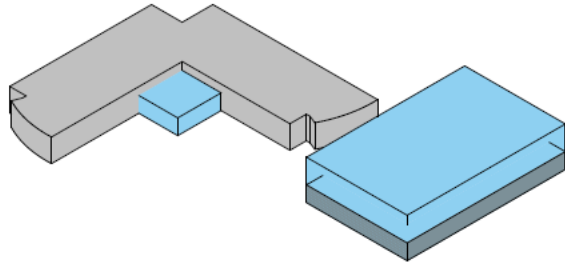

**OPTION 4** SEPARATE POLICE

PROJECT OBJECTIVES	
INVITING & APPROACHABLE	●
CREATE A CLEAR CIVIC PRESENCE	●
COMMUNITY & SERVICE FOCUSED	●
DEVELOP INTUATIVE & CLEAR CIRCULATION	⦿
EFFICIENT IN PLANNING	⦿
ALLOW FOR FUTURE EXPANSION	●
SAFE & SECURE	●
MEETS ADDITION / RENOVATION SF GOALS	○
MEETS PROGRAM GOALS	●
BUILDING REBRANDING / UNIQUE IDENTITY	⦿
DAYLIGHTING	●

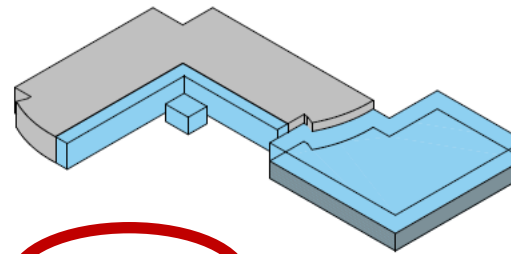

**OPTION 5** HUB & SPOKE

PROJECT OBJECTIVES	
INVITING & APPROACHABLE	●
CREATE A CLEAR CIVIC PRESENCE	●
COMMUNITY & SERVICE FOCUSED	●
DEVELOP INTUATIVE & CLEAR CIRCULATION	⦿
EFFICIENT IN PLANNING	⦿
ALLOW FOR FUTURE EXPANSION	●
SAFE & SECURE	●
MEETS ADDITION / RENOVATION SF GOALS	⦿
MEETS PROGRAM GOALS	●
BUILDING REBRANDING / UNIQUE IDENTITY	●
DAYLIGHTING	⦿

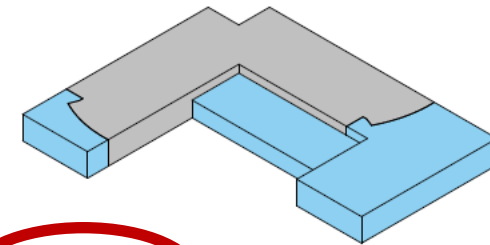

**OPTION 6** BUILDING EXTENSIONS

PROJECT OBJECTIVES	
INVITING & APPROACHABLE	●
CREATE A CLEAR CIVIC PRESENCE	●
COMMUNITY & SERVICE FOCUSED	●
DEVELOP INTUATIVE & CLEAR CIRCULATION	●
EFFICIENT IN PLANNING	●
ALLOW FOR FUTURE EXPANSION	●
SAFE & SECURE	●
MEETS ADDITION / RENOVATION SF GOALS	○
MEETS PROGRAM GOALS	●
BUILDING REBRANDING / UNIQUE IDENTITY	●
DAYLIGHTING	●



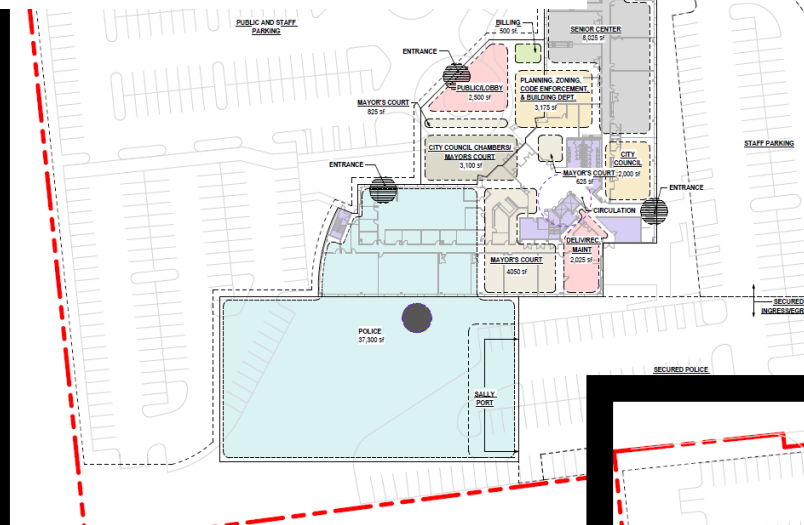
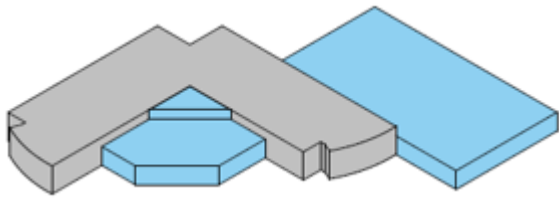

PROJECT OBJECTIVES	
INVITING & APPROACHABLE	●
CREATE A CLEAR CIVIC PRESENCE	●
COMMUNITY & SERVICE FOCUSED	●
DEVELOP INTUATIVE & CLEAR CIRCULATION	⓪
EFFICIENT IN PLANNING	⓪
ALLOW FOR FUTURE EXPANSION	●
SAFE & SECURE	●
MEETS ADDITION / RENOVATION SF GOALS	⓪
MEETS PROGRAM GOALS	●
BUILDING REBRANDING / UNIQUE IDENTITY	●
DAYLIGHTING	⓪

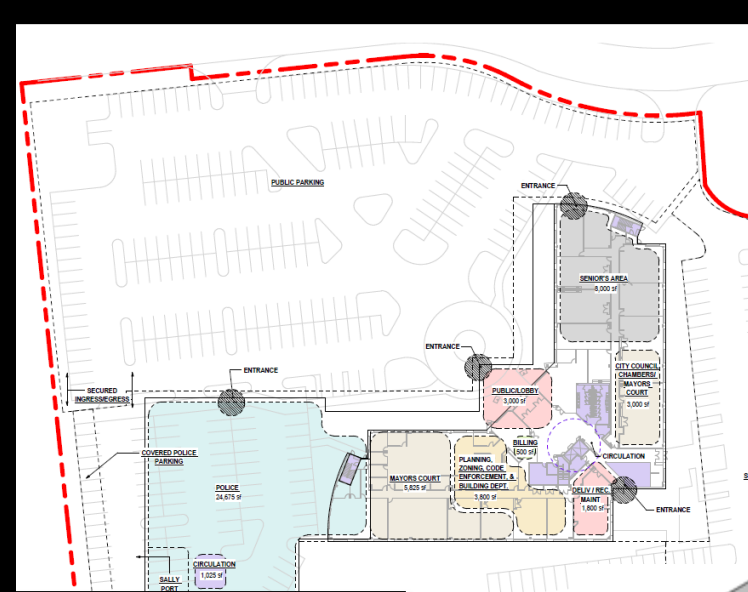

PROJECT OBJECTIVES	
INVITING & APPROACHABLE	●
CREATE A CLEAR CIVIC PRESENCE	●
COMMUNITY & SERVICE FOCUSED	●
DEVELOP INTUATIVE & CLEAR CIRCULATION	⓪
EFFICIENT IN PLANNING	⓪
ALLOW FOR FUTURE EXPANSION	●
SAFE & SECURE	●
MEETS ADDITION / RENOVATION SF GOALS	⓪
MEETS PROGRAM GOALS	●
BUILDING REBRANDING / UNIQUE IDENTITY	●
DAYLIGHTING	⓪

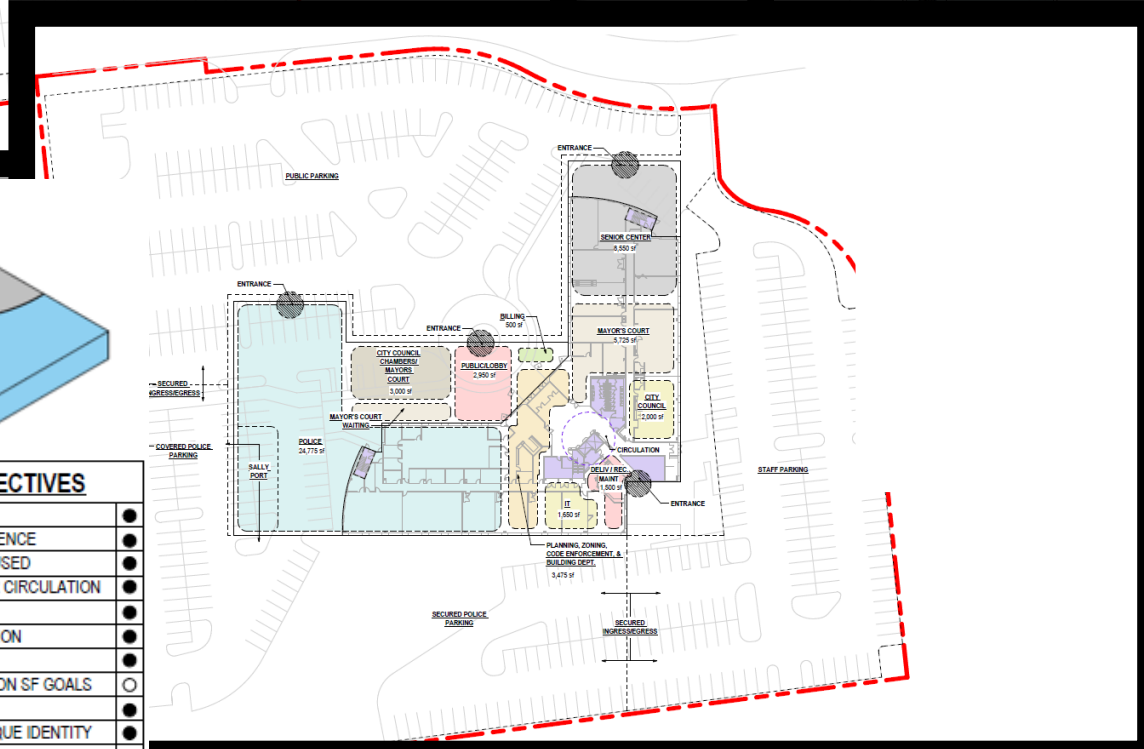

PROJECT OBJECTIVES	
INVITING & APPROACHABLE	●
CREATE A CLEAR CIVIC PRESENCE	●
COMMUNITY & SERVICE FOCUSED	●
DEVELOP INTUATIVE & CLEAR CIRCULATION	●
EFFICIENT IN PLANNING	●
ALLOW FOR FUTURE EXPANSION	●
SAFE & SECURE	●
MEETS ADDITION / RENOVATION SF GOALS	○
MEETS PROGRAM GOALS	●
BUILDING REBRANDING / UNIQUE IDENTITY	●
DAYLIGHTING	●

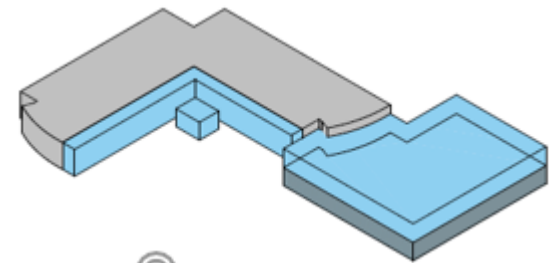

# MASSING STRATEGY

## 1 PUBLIC CIRCULATION & ENTRY

create easy to navigate public spine with light and strong identity

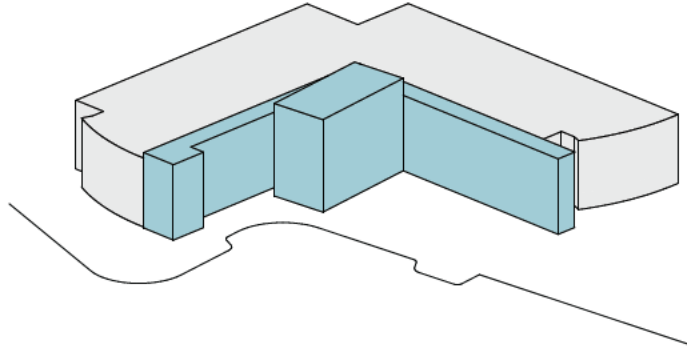

## 2 REQ'D DOUBLE HEIGHT SPACES

+council chamber  
+multi-purpose room  
+vehicle bays/sally port

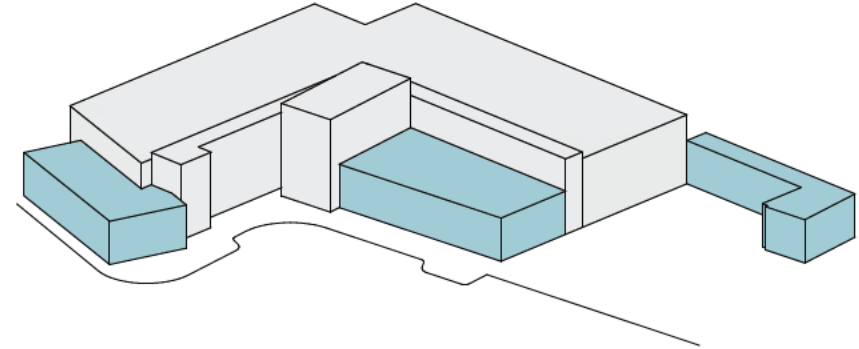

## 3 ISOLATE SENSITIVE FUNCTIONS

secure police functions with isolated entries & sensitive functions in lower level

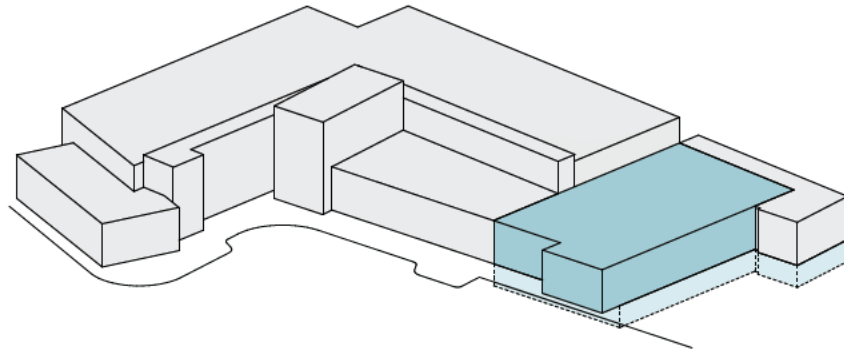

## 4 EXPERIENCE NATURE

+rear patio overlooking nature

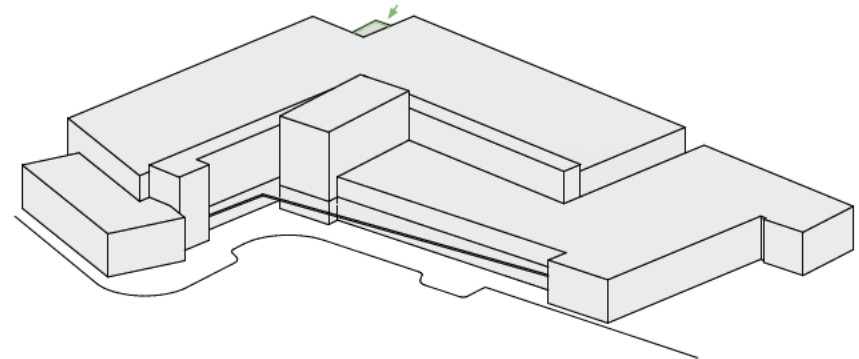

# SITE PLAN

TOTAL PARKING: 381



Public Parking:  
123

Secured Police  
Parking 68

Employee  
Parking: 34

Secured  
Employee  
Parking: 156