



CITY OF GAIHANNA

**ADDENDUM #1**

**2018 STREET PROGRAM, ST-1054**

1. The Engineer's Estimate has been revised to reflect moving Worman Drive from the base bid to an Alternate Bid #1. The Revised Engineer's Estimate is **\$3,146,600.00**.

Please attach with sealed proposal due on **March 09, 2018 @ 11:00 AM**

**ADDENDUM #1** is hereby acknowledged:

*Carl M. School* *President*  
Signature and Title

*Declar Construction Company*  
Company Name

*3/6/2018*  
Date

**Issued:** March 6, 2018

# Table of Contents

## 2018 STREET PROGRAM, ST-1054

<u>Item</u>	<u>Page</u>
Notice to Bidders .....	1
Information and Requirements for Bidders.....	2
General Provisions .....	8

### Appendix A: Supplemental Specifications

### Appendix B: Prevailing Wage

**Appendix C: Bid Documents** (all documents in this appendix must be completed and submitted at time of bid opening along with any addenda and clarifications if they were issued)

- Statement of Qualifications
- Subcontractors List
- Affidavit
- Affidavit, ORC 5719.042
- Noncollusion Affidavit
- Escrow Waiver
- Bid Guaranty and Contract Bonds
- Proposal
- Bid Tab\*

### Appendix D: Maps & Exhibits

**Appendix E: Contract** (only to be filled out *after* project is awarded)

**\*DISCLAIMER:** If a paper copy of the Bid Tab is not included within the sealed bid package, the city reserves the right to reject the bid.

## **NOTICE TO BIDDERS**

Sealed bids will be received by the City of Gahanna in the office of the Public Service Director, 200 South Hamilton Road, Gahanna, OH 43230 until 11:00am (local time) on **March 9, 2018** and publicly opened and read thereafter for:

### **2018 Street Program, ST-1054**

**Engineer's Estimate (Base Bid): \$3,629,520.00**

The base bid project consists of pavement milling, asphalt resurfacing, crack sealing, Street rebuilds, striping, and waterline improvements. The work shall commence no sooner than **April 9, 2018** and be completed by **August 14, 2018**.

Copies of the contract documents are available for review in the office of the Public Service Director, City Hall, 200 South Hamilton Road, Gahanna, Ohio 43230 without charge. Copies may be purchased for \$25, which is non-refundable.

All bids must be accompanied by a bid guaranty payable to the City of Gahanna. The preferred type is a bond for the full amount of the bid, including all add alternates, as prescribed by Section 153.571 of the Ohio Revised Code. This method must use the Bid Guaranty and Contract Bond form included in the bid documents and must be issued by a surety company or corporation licensed in the state of Ohio.

Other acceptable types of bid guaranty include a certified check, cashier's check or irrevocable letter of credit equal to ten percent (10%) of the bid, including all add alternates. If the bid is accepted using this method, a satisfactory Performance and Payment Bond must be furnished equal to one hundred percent (100%) of the bid within ten (10) days after notice of award.

If State Labor Standards Provisions and State Wage Decisions are applicable to this project it will be a part of the contract documents.

No bidder may withdraw their bid for a period of sixty (60) days after the date of the bid opening. The City will award the contract to the bidder submitting the lowest and best bid. The City reserves the right to reject any and all bids including those which in the opinion of the Public Service Director show evidence of unbalanced prices. The City also reserves the right to waive technical defects as the interest of the City may require.

Dottie Franey, Public Service Director  
Advertise: February 22, 2018 & March 1, 2018

## **INFORMATION AND REQUIREMENTS FOR BIDDERS**

**INTERPRETATION OF CONTRACT DOCUMENTS.** If any person, firm or corporation contemplating the submission of a proposal for this contract is in doubt as to the true meaning of any part of the drawings, specifications, or other contract documents, they may submit, to the Engineer a written request for an interpretation thereof. The person firm or corporation submitting the request shall be responsible for its prompt delivery. Such interpretations will be made only by a Memorandum duly issued by the Engineer and a copy of such Memorandum will be mailed or delivered to each person securing a set of the contract documents, provided that a sufficient period of time is available for the issuance and the delivery of such Memorandum prior to the receipt of bids. The Owner and the Engineer will not be responsible for any other explanations of the contract documents made prior to the receipt of bids.

**RECEIPT AND OPENING OF BIDS.** Bids will be received by the City of Gahanna, Ohio at the office of the Director of Public Service, 200 South Hamilton Road, Gahanna, Ohio 43230 until the date and time listed on the notice to bidders and will be publicly opened and read aloud at that time, all in accordance with the contract documents and any addenda thereto.

Bids must be submitted in a sealed envelope, addressed to the Director of Public Service, 200 South Hamilton Road, Gahanna, Ohio 43230. Each sealed envelope containing a bid should be plainly marked 'bid' on the outside along with the name of the stated project. The envelope should bear on the outside the name of the bidder and the bidder's address. If forwarded by mail, the sealed envelope containing the bid should be enclosed in another envelope addressed to the Director of Public Service, 200 South Hamilton Road, Gahanna, Ohio 43230.

It is the sole responsibility of the bidder to see that their bid is received in the proper time.

**ADDENDA AND CLARIFICATIONS.** If any person contemplating submitting a bid for the proposed project is in doubt as to the true meaning of any part of the contract document, they may submit to the Director of Engineering, a minimum of five (5) working days prior to the bid date, a written request for an interpretation thereof. The person submitting the request will be responsible for its prompt delivery. Please see contact information below:

**Robert Priestas, P.E. - [robert.priestas@gahanna.gov](mailto:robert.priestas@gahanna.gov) - 614-342-4050**

Any interpretation of the contract documents will be made only by addendum duly issued, a minimum of 72 hours prior to the bid opening date and time, and will be sent by both email and facsimile to each person that has obtained the bid package from the City or asked to be added to the plan holders list.

**WORKERS' COMPENSATION INSURANCE.** The contractor shall take out and maintain during the life of this contract, adequate Workers' Compensation Insurance for all his employees employed at the site of the project, and in case any work is sublet, the contractor shall require the subcontractor similarly to provide Workers' Compensation Insurance for the latter's employees, unless such employees are covered by the protection afforded by the contractor. In case any

class of employees engaged in hazardous work under the contract at the site of the project is not protected under the Workers' Compensation Statute, the contractor shall provide and shall cause each subcontractor to provide suitable insurance for the protection of his employees not otherwise protected.

In order to comply with the above requirements the contractor shall furnish and attach to each executed copy of the contract, a Workers' Compensation Certificate signed by the Ohio Industrial Commission, showing that the contractor has paid his industrial insurance premium.

**BID TAB.** The standard forms contained in the contract documents shall be used by all bidders when submitting bids. The blank spaces in the bid tab shall be properly filled in. No additional or qualifying clauses shall be written in. Unit prices shall govern in the case of a discrepancy and mathematical errors in the proposal and will be subject to correction.

**WAGE RATES.** Attention of the bidder is called to the statutory requirements of the State of Ohio included in the contract documents regarding prevailing rates of wages to be paid for all applicable work under this contract.

The contractor to whom the award is made and all of his subcontractors will be required to pay not less than the rates indicated or the various classes of work required for this improvement.

**LICENSING OF CORPORATIONS.** Particular attention is called to the statutory requirements of the State of Ohio relative to Licensing of Corporations organized under the laws of any other state.

**NON-APPROPRIATION CLAUSE.** In the event funds for this contract are not appropriated by the Council of the City of Gahanna, then the contract will automatically be cancelled without recourse to the City.

**AMOUNT OF INSURANCE REQUIRED.** The amount of such public liability insurance shall be adequate to provide full coverage for any one accident of not less than \$1,000,000 for personal injury to any one person and a total of not less than \$1,000,000 for personal injury to all persons involved. The amount of such property damage insurance shall be adequate to provide full coverage for any one accident of not less than \$1,000,000 and total of not less than \$1,000,000 for all accidents.

**AWARD OF CONTRACT.** The contract will be awarded to the lowest and best bidder. In determining the lowest and best bid, the following elements will be considered: whether the bidder involved (a) maintains a permanent place of business; (b) has adequate equipment to do the work properly and expeditiously; (c) has a suitable financial status to meet obligations incident to the work; (d) has appropriate technical experience. The city reserves the right to accept or reject any or all portions of the bid proposal.

**CITY INCOME TAX TO BE WITHHELD.** Said contractor hereby further agrees to withhold all City Income Tax due or payable under the provisions of Chapter 161 of the Codified Ordinances of Gahanna (as amended) for wages, salaries, and commission paid to its employees

and further agrees that any of its subcontractors shall be required to agree to withhold any such City Income Tax due under said Ordinance for services performed under this contract. In order to comply with this section and to avoid delay in receiving payment for work performed under this contract, it will be necessary that said contractor complete and file an "Income Tax Business Registration Form", if he/she is not already registered with the Gahanna Finance Department.

**OCCUPATIONAL SAFETY AND HEALTH ACT OF 1970.** The contractor and subcontractor shall comply with the Occupational Safety and Health Act of 1970 during the conduct and performance on and in connection with this project.

The U.S. Department of Labor, Safety and Health Regulations identified as Chapter XVII of Title 29, Code of Federal Regulations (CFR) Parts 1910 and 1926 and subsequent amendments are hereby made a part of these contract documents. All federal OSHA standards must be enforced by contractors.

**SAFETY REQUIREMENTS.** The bidder's particular attention is directed to safety requirements under Section 0.32 of the General Provisions.

**NON-DISCRIMINATION/EQUAL EMPLOYMENT OPPORTUNITY CLAUSE:**

Pursuant to ORC 125.111, the contractor agrees that the contractor, any subcontractor, and any person acting on behalf of the contractor or subcontractor, will not discriminate, by reason of race, creed, color, religion, sex, age, handicap, national origin, or ancestry, against any citizen of this state, in the employment of any person qualified and available to perform the work under this contract. The contractor further agrees that the contractor, any subcontractor, and any person acting on behalf of the contractor or subcontractor, shall not, in any manner, discriminate against, intimidate, or retaliate against any employee hired for the performance of work under this contract, on the account of race, creed, color, religion, sex, age, handicap, national origin, or ancestry. The contractor represents that it has a written affirmative action program for the employment and effective utilization of disadvantaged persons and will file a description of that program, and a progress report on its implementation, annually with the Ohio Civil Rights Commission and the minority business development office. The City agrees to post in conspicuous places, available to employees and applicants for employment, notices to be provided by the Department setting forth provisions of this nondiscrimination clause.

**PRE-CONSTRUCTION CONFERENCE.** A Pre-Construction Conference involving the Owner, the Principal Contractor, and all available subcontractors will be held, if necessary, prior to the start of construction.

**LIABILITY INSURANCE REQUIRED.** The Contractor shall hold the City free and harmless from any and all claims for damages of every nature arising out of the performance of this contract, and shall defend, at their own cost and expense, each and every suit or action brought against the City by reason thereof, until the contract has been completed. The Contractor shall furnish proof to the City of liability insurance of not less than \$1,000,000 each occurrence, \$1,000,000 aggregate for bodily injury and \$1,000,000 each occurrence, \$1,000,000 aggregate for property damage.

Umbrella Excess Liability Insurance to extend existing policies to the required limits shall be accepted.

Certificates of Insurance, naming the City as additional insured, shall be filed with the City prior to commencement of the work. These certificates shall contain a provision that coverage afforded under the policies will not be canceled unless at least thirty (30) days PRIOR WRITTEN NOTICE has been given to the city.

**NONPERFORMANCE.** Nonperformance shall constitute cause for cancellation; however, such notification shall be in writing and shall take effect thirty (30) days after said notification.

**DATE OF COMPLETION.** The Contractor shall have completed the work on or before the calendar date specified in the Notice to Bidders, or on or before a later date determined as specified herein, otherwise the owner shall proceed as provided in sections A1 and/or A2.

If the contract is revised in any material respect and it is determined that said revision will cause delay in the completion of the work, the Owner will postpone the completion date by the number of calendar days as agreed to upon by the Owner, the Contractor and Project Engineer.

If the Contractor finds it impossible for reasons beyond their control to complete the work by the date as specified or as extended in accordance with the provisions of this subsection, they may, at any time prior to the expiration of the contract item as extended, make a written request to the Owner for an extension of time setting forth therein the reasons which they believe will justify the granting of their request. The Contractor's plea that insufficient time was specified is not a valid reason for extension of time.

If the Owner finds that the work was delayed because of conditions beyond the control and without the fault of the Contractor, they may extend the time for completion in such amount as the conditions justify. The extended time for completion shall be in full force and affect the same as though it were the original time for completion.

**INCLEMENT WEATHER.** Delays caused by weather or seasonal conditions should be anticipated and will be considered as a basis for an extension of time only when the actual work days lost exceeds the number of work days lost each month due to inclement weather as determined by the following schedule:

**Number of Work Days Lost Due to Weather**

<b>Month</b>	<b># of Days</b>
May	5
June	5
July	4
August	4
September	5
October	5
November	5

The time between December 1 and April 30 is considered winter months and no extensions will be granted for this time. A workday will be counted as lost if the contract's efficiency is reduced more than fifty (50%) percent on the critical item under construction at that time. Weekends and holidays will not be counted as lost workdays.

The extended time for completion shall then be in full force and affect the same as though it were the original time for completion.

If the Owner should suspend the work in whole or in part as provided in Section 0.33 of the General Provisions, the date for completion shall be postponed the number of days that the suspension directly or indirectly delays the completion of the work.

**A-1 FAILURE TO COMPLETE ON TIME.** For each calendar day that any work shall remain uncompleted after the Contract completion date, the sum specified herein will be deducted from any money due the Contractor, not as a penalty but as Liquidated Damages; provided however, that due account shall be taken of any adjustment of the completion date granted under the provisions of this section.

Schedule of Liquidated Damages under this contract are set at **one thousand dollars per calendar day.**

The Contractor shall complete the work by the calendar dates specified in the Proposal, or by a later date determined in accordance with the specified within this provision. Requests for extension of the completion date shall be in writing and should be submitted to the Owner, prior to the calendar date set for completion in the Proposal. Failure to request an extension of the completion date, in writing, prior to the calendar date set for completion in the Proposal, will **AUTOMATICALLY** cause the deduction of Liquidated Damages, as set forth in this provision, from all estimates due and payable to the Contractor after such completion date.

Permitting the Contractor to continue and finish the work or a part of it after the date fixed for its completion, or after the date to which completion may have been extended, will in no way operate as a waiver on the part of the City of any of its rights under the Contract.

The Owner may waive such portions of the Liquidated Damages as may accrue after the work is in condition for safe and convenient use.

**A2 – CANCELLATION OF CONTRACT.** If the work to be done under this Contract shall be abandoned by the Contractor, or if this Contract shall be assigned or the work under this Contract sublet by the Contractor, otherwise than herein specified; or if before the completion of the work under this Contract, the Contractor shall become financially unable to meet their current obligations or shall become bankrupt or shall make a general assignment for the benefit of the creditors or shall have a receiver appointed for them or to take charge of their affairs or shall have their property levied upon or taken in execution or under attachment; or if, at any time, the Owner shall be in the opinion that the performance of the Contract is unnecessarily or unreasonably delayed or that the contractor is violating any of the conditions or agreements of this Contract, or is executing the same in bad faith or is not fulfilling the terms thereof, or is not



making progress in the execution of the work as to indicate its completion within the same time specified in the Contract, or within the time to which the completion of the Contract may have been extended by the Owner, then the Owner, at their discretion may at any time declare this Contract or any portion thereof, terminated by written notice served upon the Contractor, a copy of which shall be given to the Surety or the authorized agent of the Surety.

Upon the service of such notice, the contractor shall discontinue the work or such part thereof as the Owner shall designate, whereupon the Surety may, at its option, assume this Contract or the portion thereof on which the Owner has ordered the Contractor to discontinue work and proceed to perform the same and may, with the written consent of the Owner, sublet the work or portions of same taken over, provided, however, that he Surety shall exercise its option if at all, within two weeks after written notice to discontinue work has been served upon the Contractor and upon the Surety of its authorized agent. The Surety, in such event, shall take the Contractor's place in all respects and will be paid by the City for all work performed by it in accordance with the terms of this contract and if the Surety, under the provisions hereof, shall assume said entire Contract, all monies remaining due to the Contractor at the time of Contractor's default, shall thereupon become due and payable to the Surety as the work progresses, subject to all the terms of this Contract.

In the event the Owner has ordered the Contractor to discontinue work on the project, the City shall have the absolute right, without liability on the part of the City to the Contractor or their Surety, to continue and complete the project herein described. The Surety and the Contractor shall then be jointly and severally liable for all expenditures made by the City to complete the said project expecting and providing that the Surety shall not be liable for any amount over the obligation of its bond.

Any and all balances of payments due to the Contractor by the City shall be forfeited to the City and the Contractor agrees that they shall lose all right, title, and interest to the said balances, excepting and providing that the said balances shall be used, after forfeiture, for a set off to the benefit of the Contractor and the Contractor's Surety on the expenditures of the City to complete this project.

In the event, any item specified herein this section (Information for Bidders) is in direct conflict with the General Provision of the said Contract, the Information for Bidders shall take precedent.

## GENERAL PROVISIONS

**Sec. 0.01 DEFINITIONS.** Whenever the "Owner" is used or implied in these specifications, it shall refer to the City, the Party of the First Part in this Contract.

Whenever the word "Council" is used or implied in these Specifications, it shall refer to the Council of the City.

Whenever the word "Director" is used or implied in these Specifications, it shall refer to the Director of Public Service of the City, the Party of the First Part in this Contract.

Whenever the word "Engineer" is used or implied in these Specifications, it shall refer to the Director of Engineering, or his authorized assistants, acting within the scope of the duties assigned to them.

Whenever the word "Contractor" is used or implied in these Specifications, it shall refer to the Contractor, Partnership, or firm of Contractors or his or their agent or agents undertaking a contract under these Specifications.

**Sec. 0.02 AUTHORITY OF ENGINEER.** The Engineer shall have full power and authority to do any or all of the following things:

- (a) ***Interpret Plans, etc.*** To interpret the meaning of plans and specifications when necessary and to decide all questions that may arise relative to the fulfillment of this Contract.
- (b) ***Judge of Quality.*** To be the sole judge of the quality and fitness of all material and workmanship; to supervise all tests; to inspect all work and material either at the factory, on the grounds of after placing in the ground; and to condemn any work or material which, in his judgment, does not fully conform to the plans and specifications.
- (c) ***Power to Condemn.*** He may so condemn faulty work or material at any time prior to the final acceptance of the work, notwithstanding that it may have been previously overlooked or may have become damaged after previous inspection, even though it may have been estimated or paid for. Any condemned work shall be promptly taken out and replaced by the Contractor without payment and any condemned material shall be removed from the job by the contractor and not returned to any part of the work.
- (d) ***Judge Foundation Material.*** To judge the suitability of all foundations and to order unsuitable foundation material excavated to such depth as he considers necessary and the excavation refilled in such manner and with such material as he may deem proper.
- (e) ***Fix Time and Place of Work.*** To fix the time and place where work shall be started and carried on, and to order the work carried on simultaneously at two or more points if he deems necessary.

- (f) ***Length of Trench.*** To determine the length of trench which shall be kept open at any time.
- (g) ***Precautions Against Damage.*** To require additional precautions against damage to the work or any public or private property. This power shall not, however, relieve the Contractor of any responsibility for providing proper safe guards, or for any such damage or accident.
- (h) ***Extra Work.*** To sign and give orders for extra work, when such work is necessary, under the provisions of this Contract.
- (i) ***Cleaning Up.*** To order all dirt, rubbish and other material cleaned up immediately after backfilling and to have such cleaning done at the expense of the Contractor in case such cleaning done at the expense of the Contractor in case such order is not complied with within three days.
- (j) ***Remove Employees.*** To order the Contractor to remove from the project any employee who is disorderly or disrespectful or who persistently does careless or unsatisfactory work.
- (k) ***Reject Work.*** To reject work if any provision of the Contract or Specifications is being violated.
- (l) ***Repair After Completion.*** To notify the Contractor of any break, settlement or failure within one year after the date of the final acceptance of the work, and to repair the same at the expense of the Contractor if not immediately attended to by the Contractor.
- (m) ***Assistants.*** To deputize assistants and inspectors to act for him in any of his powers and duties and such assistants and inspectors shall exercise all powers of the engineer within the limits of the specific authority given by him to each.
- (n) ***Lay Out Work.*** To lay out all work, set all stakes both for lines and grade, and locate all structures and appurtenances.
- (o) ***Amount and Quality.*** To determine the amount and quality of the several kinds of work which are to paid for thereunder, including extra work.
- (p) ***Monthly Estimates.*** To prepare and sign approximate monthly estimates.
- (q) ***Final Estimate.*** To examine the work when notified of its completion and, if fully completed to his satisfaction, to make the necessary measurements and prepare and sign the final estimate.
- (r) ***Violation of Contract.*** To notify the Owner in writing of any violation of the Contract.

(s) **Extension of Time.** To determine the proper length of any extension of time provided for under this Contract.

(t) **The Engineer.** On the basis of on-site observations, shall endeavor to guard the Owner against apparent defects and deficiencies in the permanent work constructed by the Contractor; but does not guaranty the performance of the Contractor and is not responsible for construction means, methods, techniques, sequence or procedures, time of performance, programs, or for any safety precautions in connection with the construction work. The Engineer is not responsible for the Contractor's failure to execute the work in accordance with the construction contract and shall not be responsible for defects of omissions in the work result of the Contractor's or any Sub-Contractor's employees or that of any other person and entities responsible for performing any of the work result as contained in the construction contract.

**Sec. 0.03 ENGINEER TO GIVE INSTRUCTIONS.** It is mutually agreed that wherever in this contract the words "as directed", "as required", "permitted", "approval", "suitable", "ordered", "proper", "satisfactory", or words of similar import are used, they shall be understood to refer to the instructions and judgment of the Engineer as applied to each particular case.

**Sec. 0.04 PLANS AND SPECIFICATIONS.** The drawings referred to in these Specifications consist of such plans, profiles, details and drawings as may be furnished by the Engineer before or as the work progresses. Work shown on the plans and not mentioned in the Specifications, or vice versa, shall be done as if shown on both, and should any actual or apparent conflicts, inconsistencies or errors be found, the Contractor shall notify the Engineer as soon as they are discovered and shall not proceed with any work affected thereby until the matter has been properly clarified or corrected by the Engineer.

**Sec. 0.05 WORK TO BE COMPLETE.** The intent of these Specifications is to provide for the work herein outlined to be full and complete in every detail for the purposes designated, and the Contractor hereby agrees to furnish everything necessary for such construction, notwithstanding any omissions or errors in the Contract Documents.

**Sec. 0.06 EXTRA WORK.** The Contractor shall do any other work not herein provided for and which may be found necessary in order to carry out and complete more fully the work herein agreed to be done and performed, when and as ordered writing by the Engineer. Any such work may be paid for at a fair and reasonable price to be mutually agreed upon in a duly authorized supplementary contract.

Any such work, the price for which cannot be mutually agreed upon, shall be paid for at reasonable cost plus 15 percent.

The Engineer shall include in such reasonable cost, the cost to the Contractor, at current rates, of all materials used, of all labor either common or skilled, including foremen, and the fair rental of all machinery or power tools used upon the extra work for the period of such use. If said extra work requires the use of machinery not upon the work, then the cost of transportation of such

machinery to and from the work shall be added to the fair rental, provided, however, that said transportation shall not cover a distance exceeding 100 miles. The Engineer shall also include in said reasonable cost, the cost to the contractor of employer's liability insurance, workmen's compensation insurance and of public liability and property damage insurance covering bodily injuries or damage to the public resulting from the extra work.

The Engineer shall not include in said reasonable cost any cost or rental of small tools, buildings or any portion of the time of the Contractor or his Superintendents or any allowance for use of capital, or any profits, commissions or percentage of subcontractor these items being considered as in and covered by the 15 percent added to the reasonable cost, nor shall the Engineer include in said reasonable cost any cost to the Contractor of delays to the carrying out of the work occasioned by the extra work or any cost to the contractor of plant or equipment idle during the performance of the extra work.

The Contractor shall on or before the 10th day of the month succeeding that in which any extra work shall have been completed, file with the Engineer an account giving the itemized cost of such extra work, except where a supplementary contract has been entered into and shall give the Engineer access to all accounts, bills and vouchers relating thereto. In case the Contractor shall fail to file, within the time above mentioned, such accounts for extra work, he shall have no claim for compensation for the same against the Owner. No extra work will be paid for unless specifically ordered as such in writing by the Engineer or his properly authorized agents as aforesaid.

If for any reason it becomes necessary to issue an extra work order, the total payment for which will exceed \$1,000.00, the same shall be done upon written order from the Engineer duly authorized by the Owner, the work to be done and payment to be made as hereinabove specified.

**Sec. 0.07 LINES, GRADES AND ELEVATIONS.** Such lines, grades and elevations as may be deemed necessary will be given by the Engineer but this shall not be construed to mean all lines, grades and elevations. The Contractor shall provide all stakes and such other materials and give such assistance as may be required, and the marks shall be carefully preserved. He shall inform the Engineer a reasonable length of time in advance of the time and places at which he intends to work, in order that lines, grades and elevations may be furnished and so that necessary measurements for record and payment may be made with the minimum of inconvenience to the Engineer or delay to the Contractor. There shall be not special compensation to the Contractor for the cost of any of the work or delay occasioned by giving lines, grades and elevations or making other necessary measurements or by inspection; but such costs shall be considered as having been included in the prices stipulated for doing the work called for in this Contract.

**Sec. 0.08 INSPECTION.** Whenever any work is in progress an inspector shall be appointed by the Engineer to inspect the same, and it will be the duty of such inspector to see that all materials used and work performed shall be strictly in accordance with the specifications.

**Sec. 0.09 NOT RELIEVED BY INSPECTION.** The inspection of the work shall not relieve the Contractor from any of his obligations to fulfill his Contract as herein prescribed and defective work shall be made good, and unsuitable materials will be rejected notwithstanding

such work and materials have been previously overlooked by the Engineer and accepted or estimated for payment.

**Sec. 0.10 ABSENCE OF INSPECTORS.** No work shall be done in the absence of an inspector deputized by the Engineer.

Any work done in the absence of the inspector shall be removed and replaced by the Contractor at his own expense. Blasting shall be done only in the presence of an Inspector.

**Sec. 0.11 COMMENCEMENT AND COMPLETION.** The contractor shall commence work as specified in the "Notice to Contractors". The rate of progress shall be uniform insofar as contiguous work will permit, and such that on or before the time herein specified, the whole work shall have been performed and the restoration completed in accordance with the terms of the contract.

**Sec. 0.12 FAILURE TO COMPLETE ON TIME.** In case of default in completing the whole work to be done under this Contract on or before the date herein specified, or on or before a later date to which the time of said completion may have been extended by the Owner, the Contractor shall be liable for all expenses incurred by the Owner by reason of such default, including all expenses of engineering and inspection after the date set for completion. The Owner shall have the right to deduct all or any unpaid balance of said expenses from any money due or to become due the contractor. The amount still owing, if any, after such deduction, shall be paid on demand by the Contractor or his surety from any other obligations under this Contract. It is also expressly agreed that the Contractor shall be liable to the Owner for all damages from his failure to complete the work within the time limit fixed.

**Sec. 0.13 OLD MATERIAL.** All materials removed from old construction and all materials, or articles of value, found in the excavation or on the site of the work shall be brought to the attention of the Engineer; and if he shall so order, shall be the property of the Owner and shall be placed conveniently for removal. If not claimed by the Owner, such material or articles shall be removed and disposed of by the Contractor at his own expense.

**Sec. 0.14 PERMITS, LAWS AND REGULATIONS.** The contractor shall keep himself fully informed of all existing and future ordinances or resolutions of the Owner, and of all municipal, state, and national laws in any manner affecting the work herein specified and shall at all times comply with such resolutions or ordinances and laws. The contractor shall take out all permits legally required at his own expense, and shall pay all fees and charges incident to prosecution and completion of the work. He shall notify the Chiefs of Police and the appropriate Fire Department and the Engineer whenever a street or section of a street is about to be closed to traffic, also when it is to be reopened.

**Sec. 0.15 NIGHT, HOLIDAY, OR WEEKEND WORK.** No work shall be done during the Night or on Weekends or Holidays, except in case of emergencies and weather related delays encountered during the normal weekly work hours, or when written permission is given.

The contractor agrees that all work on the Contract, including any and all subcontractors, shall be conducted only during the period from one-half hour before sunrise to one-half hour after sunset, as determined by the U. S. National Weather Service. Authorization of work during any other time shall only be upon written permission of the Engineer. Whenever a valid reason exists, however, for the use of a regular night work force for continuous work, the same shall be authorized in writing by the Engineer.

The Contractor shall pay all inspection related costs, including inspector supervision on all Night, Holiday and Week-end work conducted during any hours over 40 hours per week. Inspection fees shall be paid at the overtime rate of one and one-half times the inspector's regular per diem rate.

**Sec. 0.16 WRITTEN ORDERS BY THE ENGINEER.** The Engineer shall have full authority to reject work when the Contractor refuses to follow written instruction concerning said work when such instructions are not contrary to the Specifications. Any work done subsequent to and contrary to such an order, given in writing by the Engineer, shall be at the Contractor's risk; and the Owner shall be relieved of all claims for payment for same under this Contract.

**Sec. 0.17 PUBLIC UTILITIES.** The Contractor shall assume complete responsibility for, and make satisfactory arrangements with, the management of all utilities concerned or affected by the construction of the work covered by this contract. In no case shall the services of any utilities be disrupted or interfered with without the consent of the Owner thereof, and in case any sewer, pipe, conduit, pole line, track, or other public utility property is damaged or has to be removed, the repair or removal, or removal and reconstruction if required, shall be done by the Owner of the utilities and the Contractor shall pay for the expense thereof, unless herein otherwise provided for. Call OUPS 1-800-362-2764.

**Sec. 0.18 EXISTING SURFACE, OVERHEAD AND SUB-SURFACE STRUCTURES.** An effort has been made to show on the plans such existing sub-surface structures, except service connections, as may be encountered in connection with the work under this Contract; however, it is understood by both parties hereto that all existing sub-surface, surface and overhead structures are not necessarily correct. The Contractor shall make such investigations as are necessary to determine the extent to which existing sub-surface, surface or overhead structures may interfere with the prosecution of the work contemplated under this contract.

In order to avoid damages to private sub-surface utility lines and services, as a result of excavating operations, the contractor shall give advance notice of each line or service crossing to the particular company concerned.

Should the Engineer deem it necessary, during the progress of the work, to move or relocate existing surface, overhead or sub-surface structures because of physical interference with the proposed work or to otherwise facilitate construction, the Contractor shall cause the same to be done at his own cost and expense, unless otherwise ordered or herein provided for. The Owner, however, reserves the right to make minor changes in the location of the proposed structures within the streets, alleys and easements if this is deemed advisable.

Existing surface, overhead or sub-surface structures damaged or destroyed by reason of the Contractor's operations, whether shown on the drawings or not, shall be promptly repaired or replaced in a manner satisfactory to the owners of the same at the cost and expense of the Contractor.

The Contractor shall not claim, nor shall he be entitled to receive, compensation for damages sustained by reason of the inaccuracy or incompleteness of any of the information given on the drawings or for delays occasioned in moving or relocating any existing surface, overhead or sub-surface structure or by reason of his failure to support and maintain such structures as specified.

**Sec. 0.19 PROTECTION OF EXISTING STRUCTURES.** Special attention is called to the existing structures which are located adjacent to or across the work to be constructed under this Contract. The timbering and the method of excavating shall be such as to prevent any loss of the supporting ground under or around these existing structures or damage to these structures. If directed, the Contractor shall adopt and use such special timbering, methods of excavating or safety precautions as may be necessary or required.

Extreme care shall be taken at all times during construction of the work adjacent to or across the sewers, water mains, gas mains, telephone and electric conduits, and other utilities, to the end that they will not be disturbed in any way. Smoking or any kind of open flame shall be prohibited on or about the work during the time any portion of the gas mains are exposed.

The cost of this work shall be included in the price for the various items.

**Sec. 0.20 RIGHT OF WAY.** Where shown on the plans, permanent right-of-way agreements or temporary construction easements, or both, have been obtained or are in the process of being obtained from the owner of the property. Any additional temporary construction easements required by the Contractor shall be obtained by him at the Contractor's cost. Whenever work is located in private property, it shall be done in conformity with all agreements between the Owner and the property owner or between the Contractor and the property owner as applicable.

**Sec. 0.21 INTERFERENCE WITH TRAFFIC.** The Contractor shall so pile up his material as to interfere as little as possible with traffic on the roads, streets, alleys, crossings and sidewalks. When material is piled in gutter of ditches, suitable drains of sufficient size to carry all the storm water flowing in the gutters or ditches shall first be laid. Where the drainage from cross-streets of alleys is interfered with or cut off by reason of the nature of the work, suitable crossings shall be provided for pedestrians. No material shall be piled within 20 feet of any fire hydrant and a clear way for traffic shall be provided at intersections.

In the event it becomes necessary to close any highway, street, alley or private drive to vehicular traffic, the Contractor shall, at least 24 hours in advance of such closure, notify the occupants of all premises which may be affected thereby.

**Sec. 0.22 BARRICADES AND LIGHTING.** The Contractor shall place proper barricades along and around all excavations and obstructions to traffic where danger exists, and shall place and maintain sufficient red lights at night to prevent accidents. If the Engineer is of the opinion



that sufficient barricades, warning signs and red lights have not been provided by the Contractor, at or along any of the work, the Engineer may provide such additional barricades, signs and lights as may be deemed necessary and the Contractor shall pay all costs incurred by the Owner in connection therewith. This section and any procedure by the Engineer conforming thereto shall not relieve the Contractor from properly protecting his work or from any of his obligations or responsibilities herein provided.

**Sec. 0.23 CONTIGUOUS WORK.** The Contractor shall permit the Owner, its agents, contractors for adjoining work, or contractors for additional work on the same site, to construct or install such work as the Owner may desire. Such adjoining or additional work will be constructed or installed with as little hindrance or interference as possible to the Contractor. The Contractor hereby agrees not to interfere with or prevent the performance of any adjoining or additional work by the agent or agents of the Owner. Any dispute which may arise between Contractors in regard to their adjoining work shall be adjusted by the Engineer. Furthermore, no claims for extra payment shall be made as a result of delays which may occur due to work on any contiguous or adjoining work or project.

**Sec. 0.24 SANITARY REGULATIONS.** Such sanitary regulations as may be prescribed shall be obeyed and followed by the Contractor without extra charge. Suitable sanitary convenience and plenty of pure water shall be furnished by the Contractor for the use of employees. Offensive or unsanitary conditions will not be permitted and any objectionable matter found or deposited in the trenches or excavations or about the work shall be removed by the Contractor at his own expense.

**Sec. 0.25 PATENTS.** The Contractor shall indemnify, keep and save harmless the Owner for all liabilities, judgments, costs, damages, and expenses which may in any wise come against the Owner by reason of the use of any patent material, machinery, devices, equipment, or processes furnished or used in the performance of the work under this Contract or by reason of the used of patented designs furnished by the Contractor and accepted by the Owner.

In the event that any claim, suit or action at law or in equity of any kind whatsoever is made or brought against the Owner involving any such patents, then the Owner shall have the right to retain from the money due and to become due the Contractor, a sufficient amount of money as shall be considered necessary by the Owner, to protect itself against loss until such claim, suit or action shall have been furnished to the satisfaction of the Owner. The bond given by the Contractor shall be held to protect the Owner against all claims or demands of every kind, character, and description for patent rights, licenses, and infringements.

**Sec. 0.26 BIDDERS TO EXAMINE THE SITE.** All bidders for work under this Contract are required, before submitting bids, to examine the site of work and adjacent premises and the various means of approach to the site, and to make all necessary investigations in order to inform themselves thoroughly as to the character and magnitude of all the work involved to completely execute this Contract, also as to the facilities for delivering or handling materials and plant at the site, and conditions and difficulties that will be encountered in the performance of the work specified herein. No plea of ignorance of conditions that exist, or that may hereinafter exist, or of difficulties that will be encountered in the execution of the work thereunder, as a result of

failure to make necessary examinations and investigations will be accepted as a sufficient excuse for any failure or omission on the part of this Contract, or will be accepted as a basis for any claims whatsoever for extra compensation.

**Sec. 0.27 OBLIGATIONS OF CONTRACTOR.** The Contractor shall furnish all the labor, tools, scaffolding, shoring, timbering, bracing, appliances and equipment necessary to properly and safely complete the work under this Contract, in the manner specified and within the time specified. He shall also provide all necessary machinery and plant for the proper and safe execution of the work under this Contract, and shall cover and protect the work from damage due to any cause whatsoever.

All necessary day and night watchmen, barricades, lights warning signs and such other precautions as may be necessary to protect the health and safety of the general public shall be employed, erected and performed by the Contractor who hereby agrees to hold the Owner harmless from any and all claims for damages, costs, expenses, judgments or decrees, resulting from any operations of the Contractor, his sub-contractors, agents or employees. Watchmen, lights, barricades, and warning signs provided or erected by anyone other than the Contractor shall not relieve the Contractor of his responsibility under this section.

The Contractor shall assume the defense of and indemnify the Owner and its officers and agents from all claims relating to labor and material furnished for the work, or to damage to adjacent property or premises, or to the injury of any person or persons by reason of the construction of the work under this contract, or the manner of doing the work, and shall pay any judgments obtained upon or growing out of any or all such claims.

The Contractor shall take out and maintain during the life of this Contract such Public Liability and Property Damage Insurance, including vehicle coverage issued to the CONTRACTOR and protecting him from all claims for personal injury, including death, and all claims for destruction of or damage to property, arising out of or in connection with any operations under the CONTRACT DOCUMENTS, whether such operations be by himself or by any SUBCONTRACTOR under him, or anyone directly or indirectly employed by the CONTRACTOR or by a SUBCONTRACTOR under him. Insurance shall be written with a limit of liability of not less than \$1,000,000 for all damages arising out of bodily injury, including death, at any time resulting therefrom, sustained by any one person in any one accident; and a limit of liability of not less than \$1,000,000 aggregate for any such damages sustained by two or more persons in any one accident. Insurance shall be written with a limit of liability of not less than \$1,000,000 for all property damage sustained by any one person in any one accident; and a limit of liability of not less than \$1,000,000 aggregate for any such damage sustained by two or more persons in any one accident.

Umbrella Excess Liability Insurance to extend existing policies to the required limits will be accepted.

Certificate of Insurance naming the OWNER as additional insured shall be filed with the OWNER prior to commencement of the WORK. These certificates shall contain a provision that

coverage afforded under the policies will not be canceled unless at least 30 days prior WRITTEN NOTICE has been given to the OWNER.

**Sec. 0.28 RESPONSIBILITY OF CONTRACTOR.** The Contractor shall assume full responsibility for the work, shall bear all losses resulting to him on account of the amount or character of the work, or from any unforeseen delays, obstructions or difficulties which may be encountered, or because the nature of the ground, earth or rock in or on which the work is to be done, is different from what is assumed or was expected, or on account of the weather, floods or other causes; and he shall assume the defense of, and indemnify and save harmless the Owner and its authorized agents from all claims of any kind arising from the performance of this Contract.

**Sec. 0.29 REPRESENTATIVE ALWAYS PRESENT.** The Contractor shall give his personal supervision to the faithful prosecution of the work, but in case of his absence he shall have a competent representative or foreman on the work who shall have full authority to act for him and to supply labor and material immediately and who shall follow without delay all instructions of the Engineer or his assistants in the prosecution and completion of the work and every part thereof.

**Sec. 0.30 EMPLOY ONLY COMPETENT PERSONNEL.** The Contractor shall employ only competent and skillful personnel to do the work and whenever the Engineer shall inform him that any person on the work, is, in his opinion, incompetent, unfaithful, or disorderly, or is refusing to carry out the provision of the Contract, or who persistently does careless or unsatisfactory work, or uses disrespectful, threatening or abusive language to any official having supervision of the work or to the public, such person shall be removed from the work, and shall not again be employed on this project without the written consent of the Engineer.

**Sec. 0.31 PROPER METHODS OF WORK TO BE USED.** If at any time before the commencement of or during the progress of the work, the materials or appliances used, or to be used, appear to the Engineer to be insufficient or inappropriate for securing the quality of work required, or the required rate of progress, he may order the Contractor to increase their quality and efficiency and improve their character; and the Contractor shall conform to such order; but the failure of the Engineer to demand such increase or improvement shall not release the contractor from his obligations to secure the quality of work and rate of progress specified. All materials and workmanship where the quantity, dimensions and quality are not shown on the plans, or specified in the specifications, shall be furnished in sufficient dimensions and quantities for the proper execution of the work as directed by the Engineer.

**Sec. 0.32 SAFETY REQUIREMENTS AND PRECAUTIONS.** The Contractor and Sub-Contractor shall be solely responsible for all federal, state, and local safety requirements, together with exercising precautions at all times for the protection of persons (including employees) and property. It is also the sole responsibility of the Contractor and Sub-Contractor to initiate, maintain and supervise all safety requirements, precautions and programs in connection with the work.

**Sec. 0.33 SUSPENSION OF WORK.** The Engineer or the Owner reserves the right to suspend the whole or any part of the work. If such suspensions are due to any act or failure on the part of the Contractor, or to any breach of contract on his part, he shall receive no compensation or extension of time.

Should the weather be such that any part of the work cannot be done in the proper manner with due regard to quality of materials or workmanship, or should such be the case from any other cause, then the Engineer may order such part of the work to be suspended until a more suitable season, in which case the Contractor shall cover and otherwise sufficiently protect the several parts of the work so that it will not be injured by the weather or by any other cause or agency. In such case of suspension, the time within which the Contractor is required to complete the work shall be extended by as many calendar days as the work was suspended.

Upon any stoppage of the work for any reason, all material is to be piled up snugly, so as not to impede the travel on the sidewalk or traveled way, or the use of fire plugs, and all rubbish or surplus material is to be removed immediately thereafter from the site of the work by the Contractor. The several parts of the work done are to be covered and otherwise sufficiently protected, so that it will not be injured by the weather or any other cause or agency.

**Sec. 0.34 RATE OF PROGRESS.** The rate of progress shall be as nearly uniform as practicable and shall be such that all work under this Contract will be completed within the time herein specified or on or before a later date to which the time of completion may have been extended by the Owner.

If at any time, the Engineer shall be of the opinion that the work under this Contract is unnecessarily delayed and will not be finished in the prescribed time, he shall so notify the Contractor in writing. If the Contractor fails, within 10 days thereafter, to take such measures as will, in the judgment of the Engineer, insure the satisfactory completion of all work under this Contract on or before the date specified, the Owner may then notify the Contractor to discontinue all work under the Contract in accordance with the provisions of the paragraph entitled in accordance with the provisions of the graph entitled "Breach of Contract - Surety or Owner to Complete Work," as elsewhere included herein.

**Sec. 0.35 EXTENSION OF TIME.** If the Contractor is obstructed or delayed in the prosecution or completion of the work by the neglect, delay, or default of any other contractor for adjoining or contiguous work, or by any damage that may occur to his work by the unusual action of the elements, or by any delay on the part of the Owner in doing any work or furnishing any material which may be herein provided, the Contractor shall have no claim for damages or loss of profits.

If the Contractor is obstructed or delayed as a result of one or more of the reasons mentioned above or for any other reason not herein mentioned and which the Engineer may consider just cause, the Contractor shall be entitled to such extension of the time herein specified, for completion of the work, as the Owner, upon recommendation of the Engineer, may consider fair and just. The Owner, however, shall be under no obligation to consider any

extension of time unless the Contractor has made a request in writing for such extension, within one (1) week immediately following the time when any alleged delays shall have occurred.

**Sec. 0.36 STATEMENT OF DAMAGES.** If the Contractor claims compensation for any alleged damage, make a written statement to the Engineer of the nature of said damage, and shall on or before the 10th day of the month succeeding that in which such damage shall have been sustained, file with the Engineer an itemized statement of the details and itemized amounts of such claims. Unless such statement is made, his claim for compensation shall be forfeited and invalid, and he shall not be entitled to payment on account of any such damage.

**Sec. 0.37 LOSSES.** The Contractor shall bear all losses resulting to him on account of the amount or character of the work, or because any condition encountered is different from what was expected, or on account of the weather, elements or other cause, and the Contractor hereby waives all claim for damage or loss because of ignorance of conditions on, above or under the ground, or facilities for delivery or handling materials, or any other conditions pertaining to the work, or on account of any error in the statement of approximate quantities used for comparing bids. It is expressly understood that no attempt has been made to show all underground objects on the plans and that, if any such are indicated, their location and character is not known to be even approximately correct.

**Sec. 0.38 PROTECTION OF PAVED SURFACES.** The Contractor shall so conduct his operations as to avoid damages to pavement surfaces. Mechanical equipment with lug or cleat equipped caterpillars will not be permitted on macadam, surface treated, asphalt, concrete, or other types of pavement surfaces which may be damaged thereby, unless the lugs or cleats are covered with rubber pads or otherwise protected. Any and all damage resulting from the Contractor's operations shall be satisfactorily repaired and maintained as directed by the Engineer and as herein provided at the expense of the Contractor.

**Sec. 0.39 DAMAGE TO PROPERTY.** All damage caused by the carrying out of this Contract to any pipes or conduits or other public or private property of any nature whatsoever, whether above or under the ground, including trees and crops, shall be made good to the satisfaction of the Owner of the same, at the expense of the Contractor.

**Sec. 0.40 ESTIMATED QUANTITIES.** The Contractor agrees that the estimated quantities are only for the purpose of comparing, on a uniform basis, the bids offered for the work under this Contract, and he further agrees that he is satisfied with and will at no time dispute the said estimated quantities as a means of comparing the bids aforesaid; that he will make no claim for anticipated profits or loss of profits or damages because of a difference between the quantities of the various classes of work actually furnished, and the said estimated quantities; and he agrees that the Owner shall not be held responsible if, in the construction of the work, any of the said estimated quantities should be found to be not even approximately correct, and that the Engineer may without alteration or modification of this Contract, increase, decrease, or omit the amount of any class or portion of the work as may be deemed necessary.

If any error, omission or misstatement is discovered in the said quantities, the same shall not invalidate this Contract or release the Contractor from any obligations or liabilities herein

stipulated or from the execution and completion of the whole or any part of the work, herein specified, in accordance with the specifications and plans therefore, and as required by the Engineer at the prices herein agreed upon.

**Sec. 0.41 ADDITIONS OR OMISSIONS.** The Owner may, without alteration or modification of this Contract, increase, diminish, or omit the work covered by any item of this Contract. When such item is covered by a unit price the amount actually required will be paid for; if by a lump sum price, the net addition or deduction, representing the actual value of the work added or dispensed with, shall be agreed upon before the work is done, and if agreement claim for loss of anticipated profits or damages shall be made or allowed on account of such changes, and the validity of the Contract or bond shall not be affected thereby.

**Sec. 0.42 SUBCONTRACTORS.** The contractor shall not, without the written permission and approval of the Owner, assign or sub let any part of the work to be done under this Contract.

In the event that the Contractor desires to sub let any part of the work, he shall first submit to the Owner a statement showing to whom it is proposed to sub let and the party or parties to whom it is proposed to sub let the same and his or their experience, financial ability, technical and other qualifications for properly carrying out and completing the same and the decision of the Owner as to said qualifications, financial ability, experience and competency shall be final and binding upon both parties hereto.

It is further understood and agreed that such sub letting, although approved by the Owner, shall not directly or indirectly release or modify the responsibility of the Contractor for the satisfactory and entire completion of the work under this Contract, and each and every part and portion thereof.

In case any party or parties to whom any work under this Contract shall have been sub let shall disregard the direction of the Engineer or his duly authorized representatives, or shall furnish any unsatisfactory work or shall fail or refuse in any way to conform to any of the conditions of the Contract, then, in that case, upon written order of the Engineer the Contractor shall require said party or parties in default to discontinue work under this Contract.

Any defective work done by any sub-contractor shall be removed and replaced with work which is satisfactory to the Engineer and without cost to the Owner.

**Sec. 0.43 BREACH OF CONTRACT-SURETY OR OWNER TO COMPLETE WORK.** If the Contractor fails to commence work under this Contract within the time required, or abandons the work, or any part thereof, or fails to make such progress as may be required to show reasonable promise of completion within the specified time, or violates any of the conditions of this Contract, or executes the work in bad faith, or fails to pay in lawful money for labor and material used within a reasonable time, or assigns this Contract or any part thereof without the written consent of the Owner, or if the Contractor becomes bankrupt, or makes a general assignment, or a receiver be appointed for him, the Owner may make a finding to that effect and so notify the Contractor and the Sureties in writing. The Contractor shall not remove any materials from the work after receiving such notice. If the Contractor fails, within three (3) days

thereafter, to correct the conditions set forth in such findings, or fails to continue the work thereafter in a manner satisfactory to the Owner, the Owner shall notify the Contractor to stop work and shall take possession of the work and all materials thereon (not including tools, machinery, and equipment) and the right of the Contractor to perform, control or supervise the work and to occupy the ground, shall immediately cease and the Contractor shall receive no further payment except as hereinafter stated. The Contractor shall look after and be responsible for his machinery, tools and equipment.

The Owner shall give notice to the Surety on the Bond of the Contractor that such action has been taken and the Surety shall thereupon have the right to enter upon and complete the work and to use all materials found thereon for such purpose. In case said Surety elects to so complete the work, and within ten (10) days after receiving notice of the action of the Owner, notify the Owner in writing to that effect, and within thirty (30) days after receiving such notice, enter upon and proceed with the completion of said work and carry on the work with reasonable diligence satisfactory to the Owner and in accordance with this Contract and pay all proper and legal claims for labor and material employed or purchased for the work, whether by the Contractor prior to the order to stop work or by said Surety subsequent thereto, and all legal obligations of the Contractor under this Contract for which the Surety is liable, then said Surety shall be entitled to receive all further pavements due, overdue or to become due for work done by said Contractor or said Surety under this Contract at the prices and under the conditions stated in this Contract, and the Contractor hereby agrees that under such conditions said Surety shall be surrogated to the rights of the Owner in the funds as against any other assignee. Provided, however, that if conditions on any part of the work are such that immediate work is necessary to protect life or property, or to avoid financial loss, and the Sureties fail to do such work immediately on notice from the Engineer, the Owner may cause such work to be done and charge the same to the Contractor and the Surety.

Should said Surety fail to so notify the Owner that they have elected to complete the work, or, having so notified the Owner, should said Surety fail to enter upon and proceed with the work as hereinabove stipulated, or to carry out all the obligations of the Contractor under this Contract, the Owner shall notify the Contractor under this Contract, the Owner shall notify the Contractor under this Contract, the Owner shall notify the Contractor and the Surety in writing to that effect and shall thereupon continue or resume possession of the work and all materials thereupon and all rights of said Surety to possession of the work or to receive any further payments from the Owner shall cease and the Owner shall complete the work by Contract so such other method as they deem best and may procure such tools, equipment, labor, and material as may be necessary, and charge the cost thereof and all other expenses incident to such completion to the Contractor and the Surety, who shall be credited with the value of the work done at the Contract prices herein stated. On receipt of such notice, the Contractor or the Surety shall remove all tools and equipment from the site of the work and the Owner shall not in any way be responsible for the same. If such tools and equipment are not removed within ten (10) days after such notice, the Owner shall remove the same and charge the cost of such removal to the Contractor and the Surety. Provided, however, that by written agreement between the Owner, the Contractor and the Surety, the Owner may retain and use the tools and equipment found on the work or any part thereof for the purpose of completing the work and on such completion and settlement of all obligations by the Contractor and Surety, the Owner shall release such tools and equipment, or

the remainder thereof, to the Contractor and the Surety. It is hereby agreed that there shall be no claim against the Owner for any loss or damage of such tools and equipment, whether removed by the Contractor, the Surety, or the Owner, or whether or not used by the Owner.

In case sworn claims for labor performed on the work are on file or are filed with the Owner or with the Engineer, when or after the Contractor is ordered to stop work and a schedule of such claims furnished to the Contractor and to the Surety the Owner may pay and charge to the Contractor and to the Surety such claims, or such portions thereof, as are not disputed by the Contractor or the Surety as incorrect or fraudulent within five (5) days after such schedule is furnished to them and such claims or the payment thereof shall not be later contested. The amount of any such claims disputed by the Contractor or the Surety, together with the amount of all other unpaid claims against the Contractor or the Surety filed with the Owner of the Engineer shall be withheld by the Owner for the amount thereafter to be paid to the Contractor and the Surety until such claims are settled by agreement, or litigation. In case the amounts so withheld are not sufficient to pay such claims the Contractor and the Surety shall protect, defend and save harmless the Owner, its officers and agents, from all loss and damage by reason of such claims.

If, on the completion of the work, there is a balance due the Contractor, it shall be paid to the Contractor or the Surety, as their interests may appear, under the conditions of this section and as elsewhere herein provided. If the charges against the Contractor exceed the total amount due him, the balance shall be paid to the Owner by the Contractor or his Surety within thirty (30) days after demand is made on them.

**Sec. 0.44 PRICES.** The Owner agrees to pay, and the Contractor agrees to accept, as full compensation, satisfaction and discharge for all work done and materials furnished, whether mentioned in the Estimated Quantities or not and also for costs and expenses incurred and loss or damage sustained by reason of the action of the elements or because of the nature of the work or because of any unforeseen obstruction or difficulty encountered in the prosecution of the work and also for all expenses incurred by or in consequence of, the suspension of the work was herein specified, and also for well and faithfully completing the work and the whole thereof, in accordance with the terms, conditions and provisions of this Contract and the instructions, orders and directions of the Engineer thereunder, and also for maintained the work in good condition until the final payment is made and for one (1) year thereafter, except extra work and modifications and supplementary contract which shall be paid for as elsewhere herein provided, a sum of money equal to the amount of the actual work done and material furnished, as determined by the Engineer, under each item listed in the Proposal multiplied by the unit price applicable to each such item as set forth in the Proposal attached hereto.

**Sec. 0.45 PARTIAL ESTIMATES.** The Engineer shall at least once each month make an approximate estimate of the value of the work done and materials incorporated into the work by the Contractor during the previous calendar month, whenever said monthly work exceeds One Thousand Dollars (\$1,000.00) in value. The Contractor shall assist the Engineer in the preparation of this estimate by submitting to him at the start of each month, an estimate of the work he has accomplished during the preceding month, broken down by items and containing substantiating data and computations. Allowable will be made for non-perishable materials which are to be incorporated into the work and which have been delivered and properly stored



upon the site; but if such material is stolen, destroyed, or damaged by casualty before being used, the Contractor will be required to replace it at his own expense. Payment for materials and equipment delivered and stored as specified above shall be on the basis of ninety-two percent (92%) of the paid invoices for both lump sum and unit price items. Materials and equipment delivered to the site shall become the property of the Owner upon payment therefore. The Quantities included in monthly estimates will not be determined by strict measurement or with exactness, and it shall be satisfactory if they are approximate.

**Sec. 0.46 PARTIAL PAYMENTS.** After each partial estimate has been prepared and certified and signed by the Engineer and approved by the Owner, the Owner shall, within thirty days after the date of the estimate, pay the Contractor ninety-two percent (92%) of the amount stated in the estimate; provided however, that the Owner at all times reserves and retains from any partial payment in addition to the eight percent (8%) above mentioned to be retained and reserved, any sum or sums which by the terms hereof, or of any law of the State of Ohio passed prior to the date hereof, it is or may be authorized to reserve or retain. Partial payments may at any time be withheld or reduced if, in the opinion of the Engineer, the work is not proceeding in accordance with the Contract.

**Sec. 0.47 ADJUSTMENTS OF RETAINED PERCENTAGE.** All labor performed and materials furnished and incorporated into the work after the job is fifty percent completed (as determined by the Engineer) shall be paid for at the rate of One Hundred Percent of the estimates submitted by the Contractor and approved by the Engineer. Such adjustment of retained percentage shall in no way reduce the Contractor's responsibility or in any way affect any of the other provisions of this contract. All retained funds at fifty percent (50%) completion shall be deposited in an escrow account as designated in Section 153.63 of the Ohio Revised Code.

It is further understood and agreed by the Contractor that the sums retained by the Owner, as provided in Sec. 0.46, shall be held by the Owner until completion of the entire work.

**Sec. 0.48 FINAL ACCEPTANCE.** The Contractor shall, after all work has been finished, notify the Engineer, and the Engineer shall, by personal inspection, satisfy himself as to the hereto that the actual date of completion and date of final acceptance for all purposes herein stated, shall be the date of the final estimate.

**Sec. 0.49 FINAL ESTIMATE.** The Engineer shall, as soon as practicable, after all work has been finished as required by this Contract and after the inspection by the Engineer specified above, make a final estimate of the amount of work done and the value thereof. Such final estimate will be signed by the Engineer, and the Owner shall (after such final estimate has been made and approved by the Owner) pay ninety-six percent (96%) of the sum so found to be due, after deducting therefrom all previous payments and all amounts to be kept and retained under the provisions of this contract. All prior estimates shall be subject to correction in the final estimate and payment.

**Sec. 0.50 FOUR PERCENT RETENTION.** The Contractor hereby further agrees that the Owner is hereby authorized to retain for a period of thirty days subsequent to the date of final acceptance of the work, out of the money payable to said Contractor under this agreement, the

sum of four percent (4%) of the amount of the Contract, and to expend the same in making such repairs of the said work, or in filling or grading settlements or irregularities of surfaces as may be deemed necessary, in case the same are neglected by the Contractor after reasonable notice, or are a menace to public safety.

**Sec. 0.51 MAINTENANCE.** The Contractor shall keep the work in good repair for one (1) year after date of the final acceptance and shall correct and repair promptly during that time, all breaks and failures of whatever description, and all settlement and irregularities of street or ground surfaces, and shall deliver the work in all respects in good condition at the end of that time; provided, however, that the Contractor surfaces replaced by the Owner.

**Sec. 0.52 FINAL PAYMENT.** Upon expiration of said thirty day period as herein before set forth in Sec. 0.50, the Owner shall, provided all the work covered by this Contract shall at that time be in good order and all obligations of the Contractor fulfilled, pay the Contractor such part of the four percent (4%) retained as may remain after the expense of making any repairs shall have been deducted therefrom, plus any interest accumulated from the retainage escrow account specified in Sec. 0.47. Provided that before any final payment shall be made to the Contractor, he may be required to sign a certificate that all claims for material furnished and labor performed have been paid and satisfied in full.

**Sec. 0.53 NO WAIVER OF RIGHTS.** No inspection, estimate, certificate, payment or acceptance of money, acceptance, possession, extension of time, or any other act except a specific waiver by resolution of the Owner shall operate or be construed as a waiver of any rights of the Owner under this Contract; nor shall any waiver or any breach of any condition of the Contract constitute a waiver of any other breach or condition.

All remedies in this Contract shall be taken and construed as cumulative; that is, in addition to each and every other remedy herein provided, the Owner shall have any and all equitable and legal remedies which it would in any case have.

**Sec. 0.54 RELEASE OF LIABILITY.** It is hereby agreed that no person or corporation, other than the signer of this Contract as Contractor, or the principals herein named, has any interest thereunder and no claim shall be made or be valid, nor shall the Owner or any official or agent thereof be liable for or be held to pay any money, except as provided herein. The acceptance by the Contractor of the payment of the final estimate shall operate as and shall be a release to the Owner and every officer and agent thereof, from all claims of and liability to the Contractor for anything done or furnished, for or relating to the work, or for any act or neglect of the Owner, or any person relating to or affecting the work.

**Sec. 0.55 DISCRIMINATION BECAUSE OF RACE, ETC.** In connection with the performance of work under this Contract, the Contractor agrees not to discriminate against any employee or applicant for employment because of race, religion, sex, age, handicap, color or national origin. The aforesaid provision shall include but not be limited to the following: employment, upgrading, demotion or transfer, recruitment or recruitment advertising, lay-off or selection for training including apprenticeship. The Contractor agrees to post hereafter in

conspicuous places, available for employees or applicants for employment, notices to be provided by the contracting officer setting forth the provisions of the nondiscrimination clause.

The Contractor further agrees to insert the foregoing provisions in all contracts thereunder, except sub-contracts for standard commercial supplies or raw materials.

**Sec. 0.56 ALTERATION OF CONTRACT.** When, in the opinion of the Owner, it becomes necessary in the prosecution of any work or improvement under Contract to make alterations or modifications shall only be made upon the order of the Owner, but such order shall be of no effect until the price to be paid for the work and material or both under the altered or modified Contract, has been agreed upon in writing and signed by the Owner and the Contractor.

No Contractor may recover anything for work or material because of any such alteration or modification unless the Contract is made in such manner, nor shall he be allowed to recover for such work and material, or either, more than the agreed price. The law relating to the requiring of bids and the awarding of contracts for public buildings and improvements, so far as it applies, shall remain in full force and effect.

**Sec. 0.57 OWNER INCOME TAX TO BE WITHHELD.** Said Contractor hereby further agrees to pay all Income taxes due or payable under the provisions of Codes. Contractor further agrees to withhold all Income Taxes for wages, salaries and commissions paid to his employees and further agrees that any of his sub-contractors shall be required to agree to withhold any such Income Taxes due for work performed under this Contract.

**Sec. 0.58 AWARD AND EXECUTION OF THE CONTRACT.** The award and execution of the Contract shall be made within sixty days after the date on which the bids are opened.

The failure to award and execute the Contract by the Owner within sixty days invalidates the entire bid proceedings and all bids submitted, unless the time for awarding and executing the Contract is extended by mutual consent by written agreement between the Owner or its representatives and the bidder whose bid the Owner accepts, and with respect to whom the Owner subsequently awards and executes a Contract.

If the time for awarding the Contract is extended by mutual consent, or if the Owner or its representative fails to issue a timely notice to proceed as required, the Owner or its representative shall issue a change order authorizing delay costs to the Contractor, which does not invalidate the Contract. The amount of such a change order to the Owner shall be determined in accordance with the provisions of the Contract for change orders or force accounts. In the event of a dispute between the Owner and the Contractor concerning such change order, then the cost to the Owner shall be the Contractor's actual costs including wages, labor costs other than wages, wage taxes, materials, equipment costs and rentals, insurance, and sub-contracts attributable to the delay, plus a reasonable sum for overhead.

**Sec. 0.59 BID OPENING.** The bid for which the award is to be made shall be opened at the time and place name in the Advertisement for Bids, unless extended by the Owner or its representative or unless, within seventy-two hours prior to the published time for the opening of bids, excluding Saturdays, Sundays and legal Holidays, any modification of the plans or

specifications for the project for which bids are solicited is issued and mailed or otherwise furnished to persons who have obtained plans or specifications for the project, for which the time for opening of bids shall be extended one week, with no further advertising of bids required.

**Sec. 0.60 INDEMNIFICATION.** To the fullest extent permitted by law, the Contractor shall indemnify and hold harmless the Owner and the Engineer and their agents and employees from and against all claims, damages, losses and expenses, including but not limited to attorney's fees, arising out of or resulting from the performance of the work, provided that any such claim, damage, loss or expense:

- (1) is attributable to bodily injury, sickness, disease or death, or to injury to or destruction of tangible property (other than the work itself) including the loss of use resulting therefrom, and
- (2) is caused in whole or in part by any negligent act or omission of the Contractor, any Subcontractor, anyone directly or indirectly employed by any of them or anyone for whose acts any of them may be liable, regardless of whether or not it is caused in part by a party indemnified thereunder. Such obligation shall not be construed to negate, abridge, or otherwise reduce any other right or obligation of indemnify which would otherwise exist as to any party or person described in this section.

In any and all claims against the Owner or the Engineer or any of their agents or employees by any employee of the Contractor, any Subcontractor, anyone directly or indirectly employed by any of them or anyone for whose acts any of them may be liable, the indemnification obligation under this Section shall not be limited in any way by any limitation on the amount or type of damages, compensation or benefits payable by or for the Contractor or any Subcontractor under worker's or workmen's compensation acts, disability benefit acts or other employee benefit acts.

# **Appendix A**

---

## **Supplemental Specifications**

**2018 STREET PROGRAM, ST-1054  
SUPPLEMENTAL SPECIFICATIONS**

**PROPOSAL** - No extra compensation will be paid to the contractor by reason of compliance with any of the requirements indicated in the specifications, but payment shall be deemed to be included among the several items, as bid upon, unless otherwise specifically provided.

**COMPLETION DATE** – The work under this contract shall be completed in a manner acceptable to the City on or before the date listed in the notice to bidders unless an extension of time is granted in writing by the Director of Public Service.

**REFERENCE SPECIFICATIONS** – The requirements of the City of Gahanna, together with the “Construction and Material Specifications, City of Columbus, Ohio” including all supplements thereto in force on the date of the contract, shall govern all materials and workmanship involved in the improvements, except as such specifications are modified herein.

**MAINTAINING TRAFFIC** – One lane, two-way traffic shall be maintained at all times, except for Canterwood Court, Gary Lee Drive, Oberlin Court, Walnut Street, Gamewood Drive, Shepard Street, Denwood Drive South/Foxwood Drive, Worman Drive, Brookhaven Drive East, Baroness Way, and Kenilworth Court. All traffic control devices, including lights, signs, and barricades shall be constructed, erected, and maintained in accordance with the “Ohio Manual of Traffic Control for Construction and Maintenance”.

The cost of all lights, signs, barricades, police patrolmen, and watchmen necessary to maintain the aforementioned condition shall be included in the price bid for the various items as set forth in the proposal.

Contractor shall perform and finish ALL work relative to sidewalks before performing work in the adjacent roadway. Performing sidewalk work first provides access for the adjacent properties and their residents while the roadway is under construction.

Contractor shall not perform any work in the Walnut Street/Shepard Street area until after the Blues and Jazz Festival (June 15 – 17).

**ITEM 202 SIDEWALK REMOVAL** – This item shall include the removal and disposal of existing sidewalks and curb ramps identified for removal in the proposal, where shown on the plans or deteriorated sidewalks marked for replacement by the Engineer. Also included under this item are any saw cuts necessary to provide a clean joint at the removal limits. Payment for this item will be made at the contract unit bid price per square foot.

**ITEM 203 EXCAVATION (Canterwood Court, Gary Lee Drive, Oberlin Court, Walnut Street, Gamewood Drive, Shepard Street, Denwood Drive South/Foxwood Drive, Worman Drive, Brookhaven Drive East, Baroness Way, and Kenilworth Court)** – This item shall include the removal of existing pavement, expansion joints,

additional subgrade, abandoned gas piping, and curbs as identified by the Engineer, and any other miscellaneous excavation necessary for the reconstruction of the roadway. Disposal of excavated materials shall be the responsibility of the Contractor.

Also included under this item shall be subgrade fine grading and compaction, and any saw cutting necessary between remaining sections and the sections to be removed. Payment for this item will be made at the contract lump sum price.

**ITEM 253 FULL DEPTH PAVEMENT REPAIR** – In accordance with the City of Columbus Construction and Material Specifications. This work consists of removing existing asphalt concrete, brick, PCC, or aggregate pavement courses, shaping, and compacting the exposed base material.

All repairs shall be left in a condition that is suitable to support traffic at the end of each work day, and during times of non-work periods. All repair areas shall be completed within 3 calendar days from when the work begins. “Bump” signs shall be supplied for all areas of where there is an uneven surface.

Also included under this item shall be the correction of any subgrade material as directed by the engineer.

Payment is full compensation for furnishing of all materials, labor, and equipment, including aerosol spray paint and replacement and restoration materials; cutting, removing, and disposing of existing pavement; shaping and compacting the underlying material, subgrade correction, placing new pavement; and restoring the shoulders for all labor, equipment, and incidentals necessary to complete this work.

Replacement pavement sections for roadway types shall adhere to the following:

Base repair as needed, 7” 301 asphalt concrete base (placed in two lifts), and 2” asphalt concrete surface course. The binder shall be PG64-22.

Payment for this item will be made at the contract unit price per square yard.

**ITEM 254 PLANING** – In accordance with the City of Columbus Construction and Material Specifications. Prior to asphalt concrete placement, all loose material shall be removed and disposed of by the Contractor. The edges of the remaining asphalt concrete shall be painted with RS-1, or an approved equal tack coat.

The procedure for *1” to 3” Planing* shall be to plane the existing asphalt surface down to the existing concrete surface with the exception of streets with Water-Bound Macadam base where a minimum of ½” of asphalt is to remain. Payment for this item will be made at the contract unit price per square yard.

*Butt joints* are to be 6’ wide at a depth beginning at 2” and tapering to zero to allow for 2” of asphalt to be feathered into an existing asphalt surface. This item shall be included with the unit price bid for ITEM 254 Planing. No separate payment will be made for Butt Joints.

**All planed surfaces shall be overlaid within 7 calendar days of planing completion. After the existing surface is planed, "BUMP" signs shall be provided until the surface is overlaid to provide notification of an uneven surface.**

**ITEM 306 7" CONCRETE BASE** - Item 306 – 7" Concrete Base shall reference Item 452 -- Non-Reinforced Portland Cement Concrete Pavement. The concrete proportioning shall meet the requirements of Item 499, Concrete, Class C.

**ITEM 410 TRAFFIC COMPACTED SURFACE** – This item has been included for use in aiding ingress/egress during the construction activities, Traffic Maintenance, and to achieve proper subgrade densities, as approved by the engineer. Payment for this item will be made at the contract unit price per cubic yard.

**ITEM 423 CRACK SEAL** – Type I, in accordance with the City of Columbus Construction and Material Specifications. Payment will be made at the contract unit price per square yard.

**ITEM 448 ASPHALT CONCRETE** – During the installation of the 448 intermediate and surface asphalt courses, the Contractor must be able to obtain compaction test results that are a minimum of 96% of the Maximum Theoretical Density. Prior to the start of production, the asphalt supplier shall submit the JMF (Job Mix Formula) proposed for each mix, including the Maximum Theoretical Density values.

During construction, the City will utilize nuclear gages to continually test the density of the asphalt as it is being installed to ensure that the compaction of the asphalt falls within these ranges. The Contractor shall be responsible for ensuring that proper rolling equipment is utilized to produce the densities specified. In the event the equipment is not capable of producing the densities specified, the placed material shall be removed and replaced at the Contractor's expense. These requirements are in addition to the other requirements contained within the Columbus Construction Materials Specifications.

Payment for 448 intermediate and surface courses shall be made at the contract unit bid price per cubic yard according to thickness as specified in the proposal.

**Patching** is intended to allow for 1-1/2" of asphalt to be placed on top of the milled surface to ensure the transition from the curb ramp to the pavement is compliant, as defined by the Engineer. Payment for this item will be made at the contract unit price per square yard.

**ITEM 608 CONCRETE WALK** – This work shall include the construction of new sidewalks to the lines, grades, and cross sections to meet the requirements of ADA compliant curb ramps identified in the proposal, where shown on the plans or deteriorated sidewalks marked for replacement by the Engineer. Concrete walks shall be 4" in thickness and increased to 6" in thickness for residential driveway aprons, and 8" for commercial driveway aprons. Sidewalks shall be constructed with a 3/16" per foot (1.56%) cross slope. The sidewalk construction on and Gary Lee Drive is to be a 5' wide walk with a 4' green area between the curb and sidewalk. The sidewalk construction on Walnut Street is to be a 4' wide walk with a 4' green area between the curb and sidewalk. The sidewalk is to be



installed in such a manner as to meet the existing drives, in an effort to minimize changes to existing driveways. This item shall include all excavation, removal of existing sidewalk and curb ramps as directed by the project plans or engineer including backfill, topsoil, seeding, and disposal of surplus excavation.

Included under this item shall be the adjustment, to grade, of any valve boxes, manholes, or misc. appurtenances encountered during sidewalk construction. The contractor shall furnish and install expansion material around all existing appurtenances and sidewalks as required by the Engineer. Payment for this item will be made at the contract unit price per square foot.

**ITEM 609 CURB RAMPS (ADA COMPLIANT RECONFIGURATION)** – Curb ramps shall be constructed to the lines, grades, slopes, and cross sections required to meet ADA compliance. Curb ramps shall conform to the City of Columbus Standard Drawings 2319 DR. A, except as modified herein. All ramps shall have Type E detectable warnings (Armor Tile panels or approved equal) in accordance with City of Columbus Supplemental Specification 1551.01, 1551.02, 1551.03, and 1551.04. The cost of the detectable warnings shall be included in the bid price of the ramp. Completed curb ramps not meeting ADA dimensions and slope requirements shall be reconstructed at the Contractor's expense.

Also included under this item shall be the removal and replacement of any stop signs, street name signs, 60 SF of sidewalk, and 12 LF of curb and gutter necessary due to the reconfiguration of the curb ramps for ADA compliance.

This item shall include all excavation, removal of existing sidewalk, curb ramps, and curb and gutter as directed by the project plans or engineer, backfill, topsoil, hydro-seeding, and disposal of surplus excavation.

Payment for this item shall be made at the unit bid price per ramp. This includes the ramp, detectable warnings, flared sides, curb, all sidewalk, excavation, restoration and rolled edges.

**ITEM 609 CURB RAMPS (TRUNCATED DOME REPLACEMENT)** – Curb ramps shall be constructed to the lines, grades, slopes, and cross sections required to meet ADA compliance. Curb ramps shall conform to the City of Columbus Standard Drawings 2319 DR. A, except as modified herein. All ramps shall have Type E detectable warnings (Armor Tile panels or approved equal) in accordance with City of Columbus Supplemental Specification 1551.01, 1551.02, 1551.03, and 1551.04. The cost of the detectable warnings shall be included in the bid price of the ramp. Completed curb ramps not meeting ADA dimensions and slope requirements shall be reconstructed at the Contractor's expense.

This item shall include all excavation and removal of curb ramp truncated domes as directed by the project plans or engineer, backfill, topsoil, hydro-seeding, and disposal of surplus excavation.

Payment for this item shall be made at the unit bid price per ramp. This includes the truncated dome, and all appurtenances required for the replacement, which shall include but not be limited to flared sides, ramp removal and replacement, excavation, restoration, and rolled edges.

**ITEM 609 CURB REPLACEMENT** – This work shall include the removal and the replacement of combination curb and gutter necessary for the construction of compliant curb ramps or replacement of deteriorated combination curb and gutter sections as identified and marked by the Engineer. Sections of curb to be replaced are to be a minimum length of 4 feet.

Combination curb and gutter shall be installed to the original lines, grades, and cross sections, or when near curb ramps, to the lines, grades, and cross sections required to meet ADA requirements for compliant curb ramps or as directed by the Engineer. All existing curb stamps shall be reinstalled in replacement curb sections.

This item shall include all excavation, backfill, topsoil, hydro-seeding, and disposal of surplus excavation and removed curb and gutter, furnishing and installing joint materials, restoration of private utilities including irrigation and invisible dog fences and any asphalt patching.

The joint separating the gutter from the street is required to be saw cut in areas where the concrete extends into the area to be paved. The cost of this work is to be included in this item. Also included in this item are any saw cuts necessary to provide a neat joint at the removal limits, as marked by the Engineer. Roof drain openings shall be provided through the curbs for all existing drain lines. The cost for providing these openings, and extending all existing drain lines through these openings, shall be included in this item.

Payment for this item will be made at the contract unit price per lineal foot of curb replaced.

**ITEM 614 MAINTAINING TRAFFIC** – All traffic control devices, including lights, signs, and barricades shall be constructed, erected, and maintained in accordance with the “Ohio Manual of Traffic Control for Construction and Maintenance”.

The cost of all lights, signs, barricades, police patrolmen and watchmen necessary to maintain the aforementioned condition shall be included in the price bid for this item.

Canterwood Court, Gary Lee Drive, Oberlin Court, Walnut Street, Gamewood Drive, Shepard Street, Denwood Drive South/Foxwood Drive, Worman Drive, Brookhaven Drive East, Baroness Way, and Kenilworth Court, can be closed to traffic as required for removal and reconstruction of the road. The next section of a rebuild cannot start until driveway access is permitted for the previous sections.

Once the road is closed, the construction of the new road shall be continuous so that the roadway can be opened as soon as possible to residents. Closure time shall be kept to a minimum and no longer than 16 calendar days per phase. Any exception shall be subject

to approval in advance by the City Engineer. Property owners affected by the road closure are to be given 72 hours written notice before closing the road. To minimize disruption to the residents, the contractor is to provide a minimum of (4) golf carts per section of rebuild for the entire duration of the road closure; additional golf carts may be required by the City Engineer.

**Performance of work requiring road closures cannot occur prior to May 24. Performance of minor work such as curb replacement, curb ramps, sidewalks, etc. may occur prior to May 24.**

**Work cannot be performed on the following streets at the same time: Gamewood Drive and Canterwood Court, and Walnut Street and Shepard Street. Worman Drive cannot be closed for rebuild simultaneously with the Larry Lane Bridge Replacement ST-1050 closure, The City of Gahanna will assist in coordination.**

Work cannot be performed on Walnut Street and Shepard Street until after the Creekside Blues and Jazz Festival (June 15 – 17).

Striping work cannot be performed during the Blues and Jazz Festival (June 15 – 17), Independence Day (July 3 – 4), or Vettes, Rod and Classics Car Show (August 4).

The contractor shall notify the local Fire Department and the Gahanna Police Department prior to said closings and shall make provisions for access to the roadway should an emergency require access by either the fire or police department. A quantity of *Item 410 Traffic Compacted Surface* has been included for use in providing and maintaining traffic. The use of this item shall be subject to approval by the City Engineer.

**After placement of the concrete/roller compacted concrete base, the road shall be opened within 24 hours. In addition, once the concrete/roller compacted concrete base has been placed the intermediate and surface courses for Canterwood Court, Gary Lee Drive, Oberlin Court, Walnut Street, Gamewood Drive, Shepard Street, Denwood Drive South/Foxwood Drive, Worman Drive, Brookhaven Drive East, Baroness Way, and Kenilworth Court shall be completed within 7 calendar days.**

**ITEM 623 CONSTRUCTION LAYOUT STAKES** – The Contractor shall provide all staking required to reconstruct Canterwood Court, Gary Lee Drive, Oberlin Court, Walnut Street, Gamewood Drive, Shepard Street, Denwood Drive South/Foxwood Drive, Worman Drive, Brookhaven Drive East, Baroness Way, and Kenilworth Court on present alignment and profile in accordance with the supplied sections within the Appendix. All staking shall be completed under the field supervision of a Registered Professional Surveyor. A baseline shall be established at 25-foot stations along each side of the existing curbs to establish horizontal alignment. Elevations of existing profile grade shall be obtained at the 25-foot stations and at curb inlets so that the road can be replaced on present alignment and profile. The existing and proposed grades shall be submitted to the Engineer 2 week prior to the start of construction for approval. Payment for this work shall be made at the contract lump sum price.

**ITEM 653 & 659 TOPSOIL, SEEDING, AND MULCHING** – The Contractor shall provide suitable topsoil material in accordance with Item 653 at a nominal depth of 4” to properly fill all voids and level uneven ground left by construction activities. These areas shall be hydro-seeded and mulched in accordance with Item 659. Repair seeding and mulching is included under this item and shall take place in the fall following the completion of construction and in the spring of the following year. Payment for this item will be made at the contract lump sum price for each project.

**REMOVE/REPLACE BASE OF DRIVES** – This item includes the removal, all saw cuts required to remove, disposal, and the replacement of the lower portion of each driveway approach or concrete pad adjacent to the existing curb within the roadway reconstruction limits. Limits of removal shall extend from the back of curb to the sidewalk. The drive shall be concrete 6” in thickness for residential driveways and 8” for commercial driveways from curb to walk, maintain the existing drive depth and material for any removal behind the walk. Any additional driveway that is to be removed and replaced to create an acceptable slope (15% max slope) specified by the engineer shall be included under this item. Payment for this item will be made at the contract unit price per square yard of concrete drive replaced.

**RESTORATION AND CLEANUP** – It is the intent of the City to keep inconvenience to the property owners to an absolute minimum. All work prescribed and described in these specifications is situated in improved areas. Any street signs or landscaping features removed during construction by the Contractor must be restored by the Contractor in a timely manner. The cost for removing and replacing signs, mailboxes and landscaping features shall be included in the price bid for the various items as set forth in the proposal. All work is to continue on a uniform basis and on schedule, particularly the restoration and cleanup of disturbed areas after construction. Disturbed areas such as sidewalks and curb ramps must be clearly marked by the contractor until the work can be completed. Restoration of disturbed areas shall to include the entire tree lawn. The City will pay only for those items that are completed in their entirety as described in the specifications.

**TREE AND STUMP REMOVAL** – The item includes tree removal, grinding of stumps and surface roots to a minimum depth of 6 inches below ground level. The contractor is responsible for the disposal of all trimmings, cuttings, and chippings. Payment for this work shall be made at the contract lump sum price.

**WALNUT STREET & SHEPARD STREET WATERLINE IMPROVEMENTS -**  
All work and materials shall conform to City of Columbus and City of Gahanna specifications. Where specifications conflict, the more stringent requirement shall govern. See Walnut/Shepard Street Waterline Improvement Plans for further details.

**ITEM 816 SERVICE LINE CONNECTIONS** – This item includes all materials and labor to install two bolt full wrap stainless steel saddle, corporation stop, service line, curb stop, curb box, adapter for existing service line, connection to existing service line, and all

necessary appurtenances to transfer existing service line. Payment for this item will be made at the contract unit price per each service line connection installed in place.

**CONNECTION TO EXISTING WATERLINES** – This item includes all material and labor to connect to the existing waterlines, including abandonment of existing lines, installing MJ plugs, shutting down existing line(s), resident notifications, disinfection and bacteria sampling, hydrostatic pressure test, and all necessary MJ fittings and appurtenances. Payment for this item will be made at the contract unit price per each connection made.

**CITY OF COLUMBUS  
PUBLIC SERVICE DEPARTMENT  
TRANSPORTATION DIVISION  
SUPPLEMENTAL SPECIFICATION 1503  
SOIL STABILIZATION**

**JULY 8, 2002**

- 1503.01 Description**
- 1503.02 Materials**
- 1503.03 Laboratory Mixture Design**
- 1503.04 Equipment**
- 1503.05 Storage and Handling**
- 1503.06 Construction Methods**
- 1503.07 Curing and Protection**
- 1503.08 Maintenance/Defective Areas**
- 1503.09 Basis of Payment**

**SOIL STABILIZATION**

**1503.01 Description.** This supplemental specification outlines the requirements for constructing a stabilized soil structure by uniformly mixing an approved chemical stabilizer, such as Lime, Quicklime, Fly-Ash and/or Cement with the soil and compacting the resulting mixture.

The intended purpose is to permanently strengthen and weather-proof the subgrade soil. Credit may be accorded for this process in pavement design, if all parameters of this specification are complied with.

**1503.02 Materials.** The materials used shall meet the following requirements:

**Lime.** Hydrated lime and Quicklime shall meet the requirements of section 712.04 (b) of the CMSC.

**Cement.** Cement shall meet the requirements of section 701 of the City of Columbus Construction and Material Specifications.

**Fly Ash.** Fly Ash, Class C or F, shall meet the requirements of section 705.13 and ASTM C 618. Fly Ash not conforming to these requirements may be considered, provided performance requirements of this specification can be proven.

**Water.** Water shall be clean and clear. If the water is of questionable quality, it shall be tested in accordance with the requirements of AASHTO T 26.

**Other Materials.** It is not the intent of this document to limit the use of other materials, however, it is beyond the scope of this document to focus on materials for which AASHTO and ASTM standards have not been developed. Materials not conforming to the above, may be considered, provided performance requirements of this specification can be proven.

**1503.03 Laboratory Mixture Design.** Proposed mix design proportions and recommended depth of application shall be submitted to the City by an approved geotechnical firm, selected by the Contractor, sufficiently in advance of the work for review and approval. If pavement design options are to be considered, submittals must be received no less than 45 days in advance of stabilization operations. A sufficient number of samples shall be taken to insure control data, {moisture-density relationship curve(s)}, developed in the laboratory, represents field conditions, and to account for any changes in soil type. A mix design shall be submitted for each anticipated soil type.

The proposed mix design shall yield a minimum CBR value of 20 and a minimum average unconfined compressive strength of at least 100 psi at 7 days, and at least 150 psi at 28 days.

**1503.04 Equipment.** The Contractor shall use equipment that will produce results meeting the requirements for application of materials, compaction, and finishing as

controlled by these Specifications. Mixing shall be performed using an approved power driven rotary type mixer. Prior to construction, all equipment shall be in satisfactory working condition, and available for inspection by the Project Engineer or his designee.

**1503.05 Storage and Handling.** Admixtures shall be properly stored and handled in closed weatherproof containers until immediately before distribution. Hydrated lime, Quicklime, or Cement in bags shall be properly stored in weather-protected conditions with adequate protection from ground dampness. The storage facilities shall be approved by the City.

**1503.06 Construction Methods.**

**Temperature and Weather Limitations.** Stabilization shall be performed only when ambient air temperature is above 40° F, and when the soil is not frozen. Do not perform this work during wet or unsuitable weather, or when freezing weather is anticipated within 24 hours of mixing/compaction.

**Preparation of Existing Roadway.** Prior to starting the stabilization process all unsuitable materials, such as stumps, roots, and organic material shall be removed.

Construct the area to be stabilized to an elevation such that, upon completion of the operations, the subgrade will conform to the lines, grades, and cross-section shown on the plans.

**Spreading of Material.** The admixture shall be spread using equipment that will provide uniform distribution over the entire repaired area and in such a manner as to limit scattering and loss by wind.

Tailgate spreading of material will not be permitted.

The material may be spread in either a slurry or dry form at the option of the Contractor.

**Mixing.** Mixing operations shall be such that all ingredients are distributed evenly throughout the required depth, and provide a uniform mixture, free of segregation, that is satisfactory to the Engineer. The moisture content of the mixture shall be maintained at  $\pm 2\%$  of the optimum moisture content.

The material shall be pulverized so that 100% passes the 1 inch sieve and 60% passes the #4 sieve.

**Compaction.** Immediately upon completion of the spreading/mixing operations, the mixture shall be thoroughly compacted to 98% of the maximum dry density established during the preparation of the laboratory mix design. All soil subgrade shall be compacted to 100%. The number, type, and weight of rollers shall be sufficient to compact the mixture to the required density.

If depressions, defective areas or soft spots develop during the compaction operation, they shall be corrected immediately.

After each section is completed, field density tests shall be made in accordance with COC Supplemental Specification 1501. If the compacted mixture fails to meet the specified density requirements, further evaluation by means of a test roll per section 204.07, may be performed at the discretion of the Project Engineer to evaluate subgrade stability for acceptance. The City may require the area to be reworked as necessary to meet these requirements and may require the Contractor to change compaction equipment and/or methods to obtain the required density.

**Finishing.** When compaction of the stabilized soil is nearing completion, the surface shall be shaped to the required lines, grades and cross section within the tolerances of item 203.08. Compaction should continue until the required density is obtained.

**1503.07 Curing and Protection.** After the subgrade has been finished as specified, it shall be cured for a period of at least 5 days above 40°F, or until core samples extracted from the subgrade meet the requirements of 1503.03.

During the curing period, the subgrade shall be protected against drying by applying an approved prime coat or polymer solution to prevent moisture loss.

All traffic or equipment other than curing equipment shall not be allowed on the finished subgrade until completion of curing, unless permitted by the Engineer.

**1503.08 Maintenance/Defective Areas.** The contractor shall maintain, at his expense the entire stabilized area in a manner satisfactory to the City. Maintenance shall include immediate repairs of any defective or damaged portions of the treated subgrade.

**1503.09 Basis of Payment.** The accepted quantities of stabilized soil will be paid for at the contract unit price per square yard or cubic yard, (*square meter or cubic meter*), which price and payment shall be full compensation for furnishing and placing all materials.

<u>Item</u>	<u>Unit</u>	<u>Description</u>
1503	Square Yard	Soil Stabilization

**CITY OF COLUMBUS  
PUBLIC SERVICE DEPARTMENT  
TRANSPORTATION DIVISION**

**SUPPLEMENTAL SPECIFICATION 1551 (*Modified for City of Gahanna*)  
DETECTABLE WARNINGS**

**March 1, 2004**

- 1551.01 Description**
- 1551.02 Materials**
- 1551.03 Dimensions**
- 1551.04 Application**
- 1551.05 Method of Measurement (see page 52)**
- 1551.06 Basis of Payment (see page 52)**

**1551.01 Description.**

This work shall consist of furnishing all material, equipment, and labor necessary for the placement of detectable warning devices at curb ramps or other walking surfaces, complete and ready for service at locations shown on the plans. All work shall be in accordance with City of Columbus Standard Drawing 2319 Dr. A and with Section 1108 of the Architectural and Transportation Barriers Compliance Board's "Draft Guidelines For Accessible Public Rights-of-Way", dated June 17, 2002 as amended, supplemented and adopted.

**1551.02 Materials.**

All products shall receive prior approval by the City Engineer and be included in the City of Columbus, Transportation Division current listing of approved Producers and Products for detectable warning surfaces. New Products shall be submitted for review and approval in accordance with the City's General Policy and Procedures for New Products, Materials, and Construction Procedures.

Detectable warning surfaces shall be textured to provide slip resistance and shall contrast visually with adjacent walking surfaces – either light-on-dark, or dark-on-light. The preferred color for a light background shall be brick red. The preferred color for a dark background shall be safety yellow or light granite. Other colors may be specified or approved by the City Engineer provided that samples are submitted to and approved by the City Engineer at least three (3) working days prior to installation. Color submittals shall include manufacturer's statement of percentage of visual contrast provided according to ADAAG A4.29.2. Color shall be

integral with the detectable warning device and shall not be surface applied. Paints or other surface coatings shall not be used.

Detectable warning surfaces shall be classified by type of material and/or application method:

**Type "A" – Pre-Cast, Manufactured Clay and Concrete Pavers -  
Approved for new construction, only.**



**Type "B" – Surface-Applied or Surface-Formed Domes** – Generally includes truncated domes bonded to the surface of existing curb ramps - ***Approved for retrofit, only.***

**Type "C" – Stamped, Color Dyed Concrete** - ***Approved for new construction, only.***

**Type "D" – Surface-Mounted, Thin Tile and Thin Molded Sheet Goods** – Generally includes tiles or mats (rigid & flexible, with preformed truncated domes), bonded and/or anchored to the surface of existing curb ramps - ***Approved for retrofit, only.***

**Type "E" – Pre-Manufactured, Wet-Set Products** – Generally includes rigid products pressed into freshly formed concrete - ***Approved for new construction, only.***

#### **1551.03 Dimensions.**

Truncated domes in a detectable warning surface shall have a base diameter of 0.9 inches (23 mm) minimum to 1.4 inches (36 mm) maximum, a top diameter of 50% of the base diameter minimum to 65% of the base diameter maximum, and a height of 0.2 inches (5 mm).

Truncated domes in a detectable warning surface shall have a center-to-center spacing of 1.6 inches (41 mm) minimum and 2.4 inches (61 mm) maximum, and a base-to-base spacing of 0.65 inches (16 mm) minimum, measured between the most adjacent domes on a square grid.

Detectable warning surfaces shall extend 24 inches (610 mm) minimum in the direction of travel and the full width of the curb ramp, landing, or blended transition.

Pavers shall be laid so that the centers of domes align with a straightedge placed both perpendicular and parallel with the

direction of travel. Dome Alignment may not differ by more than 1/4-inch.

The detectable warning surface shall be located so that the edge nearest the curb line is 6 inches (150 mm) minimum and 8 inches (205 mm) maximum from the face of the curb line.

Domes shall be aligned on a square grid, aligned in rows parallel and perpendicular to the predominant direction of travel. Domes must be not be skewed diagonally to the direction of travel.

#### **1551.04 Application.**

Detectable warning devices shall be installed in accordance with manufacturer's specifications, except as modified by this specification or as otherwise specified on the plans. The finished surface shall be uniformly profiled to match the adjoining surfaces without lips, obstructions and shall drain completely.

The contractor shall warrant the installed surface to last no less

than five years without losing more than two percent of the truncated domes due to delaminating as a result of product failure, and shall further warrant the surface for a minimum of five years against fading, chipping, peeling, cracking, or loss of original shade due to sunlight, salt or exposure to weathering.

**Special Application Notes: Type "A" – Pre-Cast, Manufactured Clay and Concrete Pavers:**

- Pavers shall be laid on an unreinforced concrete base. Thickness of the base shall be the greater of 4-inches or the specified, nominal thickness of the curb ramp.
- Pavers shall be set into a 1/2-inch thick bed of freshly poured latex or epoxy -modified cement mortar.
- Pavers (exclusive of domes) shall be flush with the surrounding concrete. The surface shall not differ by more than 1/8-inch in height.
- Pavers shall be laid so that the centers of domes align with a straightedge placed both perpendicular and parallel with the direction of travel. Dome Alignment may not differ by more than 1/4-inch.
- Joints between pavers and surrounding concrete surface shall be mortared and shall not exceed 1/4-inch in width. Mortared joints shall be flush with top surface and struck so as to give a smooth surface.
- Joint spacing between pavers shall be no greater than 5/32-inch and not less than 1/16-inch. Pavers shall not be directly touching each other unless they have spacing bars
- Joints between pavers shall be sand-filled. Sand shall be washed, non-plastic, well-graded angular material free from deleterious or foreign matter, with maximum particle size not larger than the specified joint spacing. Gradation shall conform to Item 703.02 fine aggregate for concrete. Sweep this material to fill the joints and water with a fine mist. Repeat as necessary to achieve a sand-filled joint. When requested by the Engineer, the Contractor shall submit gradation analysis of the proposed joint material performed in accordance with ASTM C-136.
- Pavers shall consist of full, completely formed domes and shall be crack-free.
- The face of all pavers shall be clean of cement and protected so as to avoid chipping during construction.
- A minimum of 6-inch horizontal edge restraint shall be provided around the full perimeter of the detectable warning pavers. The restraints shall consist of Class "C" cast in place concrete, (City of Columbus CMS item 499).

**CITY OF COLUMBUS  
PUBLIC SERVICE DEPARTMENT  
TRANSPORTATION DIVISION  
SUPPLEMENTAL SPECIFICATION 1523  
ROLLER COMPACTED CONCRETE PAVEMENTS (RCC)  
APRIL 15, 2006**

- 1523.01 Description**
- 1523.02 Materials Requirements**
- 1523.03 Mix Design**
- 1523.04 Equipment**
- 1523.05 Placing RCC**
- 1523.06 Compaction and Finishing**
- 1523.07 Small Areas**
- 1523.08 Joints**
- 1523.09 Curing**
- 1523.10 Tolerances**
- 1523.11 Quality Assurance and Control**
- 1523.12 Defective RCC**
- 1523.13 Asphalt Surfacing / Opening to Traffic**
- 1523.14 Warranty**
- 1523.15 Basis of Payment**

**ROLLER COMPACTED CONCRETE PAVEMENTS  
(RCC)**

**1523.01 Description**

This Supplement outlines the requirements for production and construction of Roller Compacted Concrete (R.C.C.) pavement for City streets. In addition to this supplement, items 305, 306, 401, 407, 451, and 700 of the City of Columbus Construction and Material Specifications (CMSC) apply where applicable.

**1523.02 Materials Requirements**

All materials to be used shall be from approved sources as documented on the "Approved Materials List" on file in the City's testing laboratory.

Cement: Portland Cement shall conform to the standard specification for Portland Cement Type I, ASTM C 150 (latest edition).

Fly Ash: Fly Ash shall conform to ASTM C 618 Class F and section 705.13 of the CMSC.

Aggregates: Fine and course aggregates shall meet the requirements of section 703.02 of the CMSC for Portland Cement Concrete, item 305 and 306. The aggregates shall be well graded to conform to the following composite gradation.

<u>Sieve Size</u>	<u>Percent Passing</u>
1"	100
3/4"	90 - 100
1/2"	70 - 90
3/8"	60 - 85
#4	40 - 70
#16	20 - 40

#100	5 - 20
#200	2 - 8

Water: Clean, potable and free from oil, acid, and strong alkalies or organic materials.

Admixtures (other than fly ash): Meet applicable ASTM standards.

### **1523.03 Mix Design**

The Contractor/Supplier shall develop an R.C.C. mixture proportioned in accordance with this specification and procedures discussed in ACI 325.10R-95 "State-of-the-Art Report on Roller-Compacted Concrete Pavements" sections 4.2 and 4.3. Once the mix has been designed, certified test data shall be submitted in accordance with Section 101.10 of the CMSC from a recognized testing laboratory that shows the proposed mix design will meet the following requirements.

Compressive Strength, Cylinders: 3500 psi @ 28 days  
Flexural Strength, Beams: 500 psi @ 14 days  
Splitting Tensile Strength, Cores: 400 psi @ 14 days

The minimum Cementitious Material shall be 350 pounds per C.Y.

Fly Ash may only be used between April 1 and November 1 unless otherwise authorized by the Project Engineer.

### **1523.04 Equipment**

**Mixing Plants:** Mixing plants shall be of a design that can produce an R.C.C. pavement mixture of the proportions defined in the approved mix design and within the specified tolerances in ASTM C 94 and ASTM C 685. The mixing plant may be a Central-Mix Drum or a Stationary Continuous-Mixing Twin-Shaft Pugmill mixer. The plant shall have a minimum manufacturer's rated capacity of 200 tons per hour.

**Paver:** RCC shall be placed with a high-density or conventional asphalt type paver subject to approval by the Engineer. The paver shall be capable of placing RCC to a minimum of 85% of the maximum wet density in accordance with ASTM D 1557 or equivalent test method. The paver shall be of suitable weight and stability to spread and finish the RCC material, without segregation, to the required thickness, smoothness, surface texture, cross-section and grade.

**Alternative Paving Equipment.** In areas not accessible to paving machines, alternative paving equipment including graders and dozers may be used, if approved by the Engineer. The equipment shall be capable of producing a finished product that results in a smooth, continuous surface without segregation, excessive tearing, or rock pockets. Work in areas inaccessible to paving machines will be performed according to 1523.07 of these specifications.

**Pneumatic Rollers:** Pneumatic rollers shall be self-propelled, with overlapping tire positions capable of providing full compaction in a single pass. Static weight shall be no less than 10 tons, or more than 20 tons. Tire configuration shall be 5 front and 6 rear.

**Vibratory Rollers:** Vibratory rollers shall be self-propelled, double drum, steel wheel vibratory rollers having a static weight of at least 10 tons. Each roller drum shall be equipped with a properly operating scraper and brush. The rollers shall transmit a dynamic impact to the surface through smooth steel drums by means of revolving weights, eccentric shafts or other equivalent methods. The roller drum shall be between 4 and 5-1/2 foot in diameter and 5-1/2 to 8 feet in width.

Finish Rollers: Finish rollers shall be self-propelled, double drum, steel wheel rollers having a static weight of between 3 and 10 tons. Each drum shall be equipped with a properly operating scraper and brush. A single drum vibrator roller with a vulcanized rubber coating may be utilized for finish rolling, at the approval of the engineer.

Equipment for Vertical Cuts in R.C.C. Pavement: To cut vertical joints in fresh R.C.C. pavement, equipment such as a wheel cutter or other approved equipment capable of cutting vertically, the full depth of the layer, shall be used. If the Contractor waits until the R.C.C. hardens to make vertical cuts, concrete sawing equipment shall be used to make the vertical cuts.

### **1523.05 Placing RCC**

Cold Weather Limitations: R.C.C. shall not be placed on any surface containing frost or frozen material. R.C.C. shall only be placed when the ambient temperature is a minimum of 35°F and rising, unless the procedures set forth in section 451.061 "Depositing and Curing Concrete During Cold Weather", of the Construction and Material Specifications, are strictly adhered to. Conformance will be closely monitored and stringently enforced.

Hot Weather Precautions: During periods of hot weather or windy conditions, special precautions shall be taken to minimize moisture loss due to evaporation. Precautions may include cooling of aggregate stockpiles by the use of a water spray, protective covers on dump trucks, temporary windbreaks to reduce wind velocity, cooling of concrete mix water, decreasing the allowable time between mixing and final compaction, and keeping the surface of the newly placed R.C.C. pavement damp with a light spray during compaction and finishing operations.

Rain Limitations: No placement of R.C.C. pavement shall be done while it is raining hard enough to be detrimental to the finished product. Placement may continue during light rain or mist provided the surface of the R.C.C. pavement is not eroded or washed. Dump truck covers must be used during these periods. The Engineer will be the sole judge as to when placement must be stopped due to rain.

Subgrade Preparation: Prepare the subgrade according to Section 204 of the CMSC. If required, construct a granular base according to Section 304.

Moisten the surface of the subgrade or base without creating mud or ponding water, to minimize absorption of water from R.C.C. mix to be deposited.

Transporting: Transport the R.C.C. mixture to the site in dump trucks with boxes cleaned out before loading and provided with protective covers properly secured in place until discharge. The trucks shall dump directly into the hopper of the paver unless placement is by hand as directed by the Engineer. Hauling over the freshly placed R.C.C. will not be permitted.

Continuity: Co-ordinate R.C.C. delivery so the mix can be spread and rolled within the specified time limit and to ensure uniform progress of the paver until the paving operation is complete. The time between mixing, and compacting shall not exceed ninety ( 90 )minutes, for all RCC placed, provided that the temperature of the RCC does not exceed 90 degrees (F). This time limit may be increased or decreased by the Engineer dependent upon ambient conditions of temperature and humidity.

Spreading: Spread the material to a sufficient depth that will produce the specified thickness when compacted and conform to the required cross-sections and grade. Operate the paver in a manner that will prevent segregation and will produce a smooth continuous surface without tearing, pulling or shoving. Placing of the R.C.C. mix shall be done in a pattern so that the water from previously placed R.C.C. will not affect the fresh surface or subgrade. Where required, broadcasting or fanning of R.C.C. must be performed immediately behind the paver. Any R.C.C. surface that has been compacted "rolled" but is not cured, must be scarified at least one inch

deep prior to broadcasting fresh R.C.C. over the top. Broadcasting must be completed in the allotted time within these specifications.

**Segregation:** If segregation occurs, suspend the paving operation until the cause is determined and corrected. Rake off segregated coarse aggregate before rolling. Broadcasting or fanning of R.C.C. mixture onto areas being compacted is not permitted.

**Placing Adjacent Lanes:** All R.C.C. on both sides of the longitudinal joint formed by placing an adjacent lane, must be compacted within 90 minutes of plant mixing, unless a cold joint is provided.

#### **1523.06 Compaction and Finishing**

**Required Density:** The Contractor is responsible for achieving 98% of the maximum wet density, as determined in the laboratory according to ASTM D 1557.

**Start of Rolling:** Begin compaction operations within fifteen (15) minutes after spreading of the R.C.C. mix. Any additional delay will result in the coring of the affected area at the Contractors expense to ensure that it meets the requirements of this specification.

**Rolling Pattern:** Establish a rolling pattern that will achieve the required density with a minimum number of roller passes.

**Vibratory Rolling:** During vibratory compaction, the roller shall not be started, stopped, or left standing in vibratory mode. Stagger the stopping point of successive rolling passes to avoid forming depressions on the surface.

**Surface Check:** Continually check the R.C.C. surface while still plastic to ensure surface and grade tolerances are met. Immediately correct excessive variations in accordance with the spreading requirements.

**Finish Rolling:** Remove any roller marks on the surface using a steel drum roller in static mode.

**Lane Edge:** Each edge of each lane shall be constructed with a vertical or a 15-degree from vertical configuration.

#### **1523.07 Small Areas**

Spread RCC mix by hand in areas not accessible by the paver, as directed by the Engineer.

Compact the mix to the required density using suitable walk-behind vibratory compaction equipment. The vibratory equipment must have a minimum centrifugal force of 2,200 pounds and/or 70 pounds per square inch. Compaction of these areas must be performed immediately after placement of the R.C.C. in order to avoid moisture loss.

#### **1523.08 Joints**

**Fresh Joint:** A fresh joint is made when R.C.C. on both sides of the joint are compacted within 90 minutes of plant mixing. Ensure that the contact face is moist and not segregated. Before rolling, hand-finish the joint as necessary to produce a tight surface. Roll extra passes as necessary to achieve the required density and smoothness in the joint area.

**Cold Joint:** A cold joint is made when either side of the joint is not compacted within 90 minutes of plant mixing. Sawcut the edge of previous lane back to sound R.C.C. to form a vertical

face. Trimming by grader blade may be permitted if done at the end of the workday or the first thing the following day. Place fresh grout on the vertical face just before placing fresh R.C.C. against it. Before rolling, hand-finish the joint as necessary to produce a tight surface. Roll extra passes as necessary to achieve the required density and smoothness in the joint area. Every effort shall be made to maintain longitudinal joints as a fresh joint as described in "Fresh Joint" above.

**Transverse Joint:** May be a Fresh Joint or Cold Joint as described above. They shall be spaced at a maximum of 30 foot intervals, or at intervals directed by the Engineer and cut to a depth 1/3 of the specified pavement thickness.

**Longitudinal Joint:** Leave the outer 12 to 18 in. of the paving lane uncompacted during the initial rolling operation. This uncompacted edge is then used to set the height of the paver screed for paving the adjacent lane. After the adjacent lane is placed, the joint is compacted by centering the roller drum over the joint and compacting the adjacent lane edges simultaneously.

#### **1523.09 Curing**

R.C.C. without Asphalt Surfacing applied within 72 hours: Keep the R.C.C. surface continuously moist by water, fog spray, wet burlap, or an approved membrane-forming curing compound, or polyethylene sheeting for a period of 7 days. Apply curing compound at 1-1/2 times the rate specified by the manufacturer.

R.C.C. with Asphalt Surfacing applied within 72 hours: Immediately after final rolling, apply an asphalt emulsion per item 407 of the CMS. Apply at 1-1/2 times the rate specified by the manufacturer.

#### **1523.10 Tolerances**

R.C.C. pavement construction shall be subject to Section 451 of the CMSC.

#### **1523.11 Quality Assurance and Control**

**Responsibility:** Testing at the plant and the paving site is the responsibility of the Contractor or Developer and shall be performed by a private Independent Testing Laboratory approved by the City. The Contractor and Supplier shall provide safe and convenient access, acceptable to the Engineer, for the inspection and sampling of the R.C.C. and constituent materials, at both the production plant and the paving site, and shall cooperate in the inspection and sampling process at all times.

**Test Strip:** The contractor shall construct a test section of a thickness equal to the design thickness with at least 100 tons of R.C.C. The test strip will be used to resolve anticipated problems with equipment, mix behavior, compaction, and/or strength characteristics. The test strip shall be constructed at a location chosen by the contractor at least 30 days before the start of paving operations. The contractor shall cooperate fully with the Engineer during construction and testing of the test strip. During construction of the test section, the Contractor will establish an optimum rolling pattern and procedure for obtaining a density of not less than 98% of the maximum wet density in accordance with ASTM D 1557. In addition, the Contractor must also demonstrate the ability to achieve a smooth, hard, uniform surface free of excessive tears, ridges, spalls and loose material. After completion of the test section, beams and cores will be extracted to verify mix compliance. This will be performed by the Independent Testing Laboratory, at the expense of the Contractor. During the trial placement, the City's Testing Personnel shall calibrate their nuclear density gauges in accordance with ASTM C 1040, with a sample of the test section mix. Moisture readings of the gauge shall be calibrated using oven dry samples of the plant-

mixed R.C.C. If all aspects of the test strip have been previously satisfied, the engineer may waive this requirement on a project-by- project basis.

**Pre-placement:** The Contractor shall ensure quality control at the plant, by controlling materials, obtaining test samples and ensuring segregation is not occurring while loading haul trucks.

The private Testing Laboratory will develop a moisture/density relationship of the actual job materials in accordance with ASTM D 1557. Optimum moisture content, maximum dry and wet densities will be established.

**Compressive Strength Testing:** During the mix design development, the Independent Testing Laboratory shall produce six (6" x 12") diameter cylinders, in accordance with ASTM C 1435, to perform a 28 day compressive strength test of the material to verify mix conformance. Handling and curing shall be in accordance with ASTM C 31. The Engineer may require additional tests at different ages. Compressive strength testing shall be in accordance with ASTM C 39.

**During Placement:** The Contractor, in cooperation with the Independent Testing Laboratory, shall ensure that compaction and grade specifications are met and time limits are adhered to.

**Field Density:** The contractors Testing Laboratory shall perform density testing of the R.C.C. in accordance with ASTM C 1040, direct transmission mode, as soon as possible, but no more than 30 minutes, after completion of rolling. Only wet density shall be used for evaluation. The required density shall be a minimum of 98% of the maximum wet density. At least 5 tests shall be performed for each 250 cubic yards placed. The Contractor shall be responsible for verifying required densities are achieved by the paver.

If density tests indicate that the material does not meet the required density, the Engineer, in collaboration with the Contractor and the Independent Testing Laboratory, shall determine the source of the problem, whether mix properties, segregation, or gauge calibration. If mix properties have changed, or the concerns cannot be resolved, placement shall be suspended until the problem is corrected.

**After Placement:** The contractors Testing Laboratory shall core at least nine (9) 3 1/2 inch diameter cylindrical specimens from the interior of the slab for compliance verification. Length measurements of the cores and compressive strength testing shall be in accordance with ASTM C 42. The actual number of cores will be determined as defined in section 451.16 of the CMSC.

Testing will be conducted as follows:

**Compressive Strength Testing:** Three (3) of the cores obtained for thickness verification will be tested for compressive strength at 28 days.

**Splitting Tensile Strength:** Three (3) of the cores obtained for thickness verification will be tested for splitting tensile strength at 14 days.

**Density Test:** The three (3) core samples obtained for splitting tensile strength will also be tested for density PCF.

The remaining three cores will be held for backup testing and/or further review as necessary.

**Flexural Strength Testing:** At the option of the project Engineer, the Contractor/Independent Testing Laboratory shall cut at least three (3) rectangular beams from the interior of the slab, in accordance with ASTM C 42, to perform a 14 day flexural strength test of the material. Additional tests at different ages may be required by the Engineer.



**1523.12 Defective RCC**

Repairs: All repairs are subject to the Engineers approval. Correct deficiencies while R.C.C. is still plastic; otherwise do repairs after seven (7) days. After seven (7) days, the R.C.C. shall be removed by saw cutting full depth before removal. Replace the R.C.C. utilizing a Cast-in-Place concrete meeting the requirements of section 499; Class B or E Concrete as directed by project Engineer. The new concrete shall be doweled into the existing R.C.C. utilizing epoxy coated reinforcing bars unless the RCC option is utilized.

Remove and replace R.C.C. if determined deficient in thickness by following the procedure set forth in section 451.16 of CMSC.

Any R.C.C. pavement found to be of unacceptable thickness, or deficient in any testing done according to 1523.11, may be subject to removal and replacement by the contractor, at no cost to the City, including removal and replacement of any intermediate and surface asphalt courses.

Grind off high surface variations to a finish acceptable to the Engineer.

Filling of low areas with fresh R.C.C. is not permitted.

If asphalt surfacing is specified, low areas shall be made up with additional surfacing material without extra payment.

**1523.13 Asphalt Surfacing / Opening to Traffic**

The R.C.C. pavement may be asphalt surfaced as specified on the plans once the requirements of Section 1523.06 have been met and all transverse contraction joints have been constructed.

If the R.C.C. pavement is not to be asphalt surfaced immediately, all traffic shall be restricted from using the R.C.C. until seven (7) days has elapsed or all strength requirements of Section 1523.03 have been met. At any time prior to the expiration of the above mentioned seven (7) day period, the R.C.C. may be asphalt surfaced as specified on the plans and then opened to traffic.

**1523.14 Warranty**

Pavement constructed according to this specification shall be guaranteed by the developer/owner for a period not less than two (2) years from date of acceptance of the street by the City Engineer.

**1523.15 Basis of Payment**

The accepted quantities of R.C.C. pavement will be paid for at the contract unit price per square yard (*square meter*), which price and payment shall be full compensation for furnishing and placing all materials including reinforcing steel, dowels, and joint materials.

No additional payment over the unit contract bid price will be made for any pavement which has an average thickness in excess of that shown on the plans.

Payment for accepted quantities, complete in place, will be paid for at the contract price for item Supplemental Specification 1523.

<u>Item</u>	<u>Unit</u>	<u>Description</u>
1523	Square Yard	Roller Compacted Concrete

STANDARD SPECIFICATIONS  
FOR  
ASPHALT SURFACE PRESERVATION  
WITH AN  
ASPHALT REJUVENATING AGENT

**ASPHALT REJUVENATING AGENT****I. Scope:**

This work shall consist of furnishing all labor, material, and equipment necessary to perform all operations for the application of an asphalt rejuvenating agent to asphaltic concrete surface courses. The rejuvenation of surface courses shall be by spray application of a maltene based cationic rejuvenating agent composed of petroleum oils and resins emulsified with water. All work shall be in accordance with the specifications, the applicable drawings, and subject to the terms and conditions of this contract.

**II. Material Specifications:**

The asphalt rejuvenating agent shall be an emulsion composed of a petroleum resin oil base uniformly emulsified with water. Each bidder must submit with his bid a certified statement from the asphalt rejuvenator manufacturer showing that the asphalt rejuvenating emulsion conforms to the required physical and chemical requirements.

**SPECIFICATIONS**

<u>Tests</u>	<u>Test Method</u>		<u>Requirements</u>	
	<u>ASTM</u>	<u>AASHTO Min.</u>	<u>Max.</u>	
<u>Tests on Emulsion:</u>				
Viscosity @ 25°C, SFS	D-244	T-59	15	40
Residue, % W <sup>1</sup>		D-244 (Mod.) T-59 (Mod)	60	65
Miscibility Test <sup>2</sup>	D-244 (Mod.)	T-59 (Mod)	No Coagulation	
Sieve Test, %W <sup>3</sup>	D-244 (Mod.)	T-59 (Mod)	-	0.1
Particle Charge Test	D-244	T-59	Positive	
Percent Light Transmittance <sup>4</sup>	GB	GB	-	30
<u>Tests on Residue from Distillation:</u>				
Flash Point, COC, °C	D-92	T-48	196	-
Viscosity @ 60°C, cSt	D-445	-	100	200
Asphaltenes, %w	D-2006-70	-	-	1.00
Maltene Dist. Ratio		D-2006-70	-	0.3 0.6
$\frac{PC + A_1^5}{S + A_2}$				
PC/S Ratio <sup>5</sup>	D-2006-70	-	0.5	-
Saturated Hydrocarbons, S <sup>5</sup>	D-2006-70	-	21	28

<sup>1</sup> ASTM D-244 Modified Evaporation Test for percent of residue is made by heating 50 gram sample to 149 C (300 F) until foaming ceases, then cool immediately and

calculate results.

<sup>2</sup> Test procedure identical with ASTM D-244-60 except that .02 Normal Calcium Chloride solution shall be used in place of distilled water.

<sup>3</sup> Test procedures identical with ASTM D-244-60 except that distilled water shall be used in place of two percent sodium oleate solution.

<sup>4</sup> Test procedure is attached.

<sup>5</sup> Chemical composition by ASTM Method D-2006-70:

PC = Polar Compounds, A<sub>1</sub> = First Acidaffins  
A<sub>2</sub> = Second Acidaffins, S = Saturated Hydrocarbons

## PROCEDURE FOR DETERMINING PERCENT LIGHT TRANSMITTANCE ON ASPHALT REJUVENATING AGENT

### A. SCOPE

This procedure covers the determination of percent light transmittance of the asphalt rejuvenating agent.

### B. APPARATUS

- 1) Container may be either glass, plastic or metal having a capacity of 6,000 ml.
- 2) Graduated cylinder, 1,000 ml, or greater
- 3) Light transmittance measuring apparatus, such as Bausch and Lomb or Lumetron spectrophotometer
- 4) Graduated pipette having 1 ml capacity to 0.01 ml accuracy
- 5) Suction bulb for use with pipette
- 6) Test tubes compatible with spectrophotometer, 3/4" X 6, Bausch and Lomb, Catalog No. 33-17- 81, (B&L)

### C. CALIBRATION OF SPECTROPHOTOMETER

1) Calibrate spectrophotometer as follows: (a) Set wavelength at 580 mu, (b) Allow spectrophotometer to warm-up thirty minutes, (c) Zero percent light transmittance (%LT) scale, (d) Rinse test tube three times with tap water and fill to top of circle marking on B&L test tube or approximately 2/3 full, (e) Place tube in spectrophotometer and set %LT scale at 100, and (f) repeat steps (c) and (e) two times or until no further adjustments are necessary.

### D. PROCEDURE

- 1) Shake, stir or otherwise thoroughly mix emulsion to be tested. Place sample of emulsion in beaker and allow to stand one minute.
- 2) Place 2,000 ml tap water in container.
- 3) Suck 1.00 ml emulsion into pipette using suction bulb. Wipe off outside of pipette.
- 4) Using suction bulb, blow emulsion into container.
- 5) Rinse pipette by sucking in diluted emulsion solution and blowing out.
- 6) Clean pipette with soap or solvent and water. Rinse with acetone.
- 7) Stir diluted emulsion thoroughly.
- 8) Rinse out tube to be used with the diluted emulsion three times and fill to top of circle.
- 9) Calibrate spectrophotometer.
- 10) Place diluted emulsion sample tube in spectrophotometer, cover and read %LT to nearest tenth.
- 11) Repeat steps 9 and 10 until three identical consecutive readings are achieved.
- 12) The elapsed time between addition of emulsion to dilution of water and final %LT reading should not exceed 5 minutes.

**III. Material Performance:** The asphalt rejuvenating agent shall have the capability to penetrate the asphalt pavement surface. The asphalt rejuvenating agent shall be absorbed and incorporated into the asphalt binder. Verification that said incorporation of the asphalt rejuvenating agent into the asphalt binder has been effected shall be by analysis of the chemical properties of said asphalt binder i.e. viscosity shall be improved to the following extent. The viscosity shall be reduced by a minimum of forty, (40%) percent as determined by dynamic shear rheometer (DSR) method for asphalt testing in accord with AASHTO T315-05. This analysis shall apply to extracted asphalt binder, taken from cores extracted fifteen to thirty days following application, in the upper 3/8" of pavement. In addition the treated areas shall be sealed in-depth to the intrusion of air and water.

The rejuvenating agent shall have a record of at least five years of satisfactory service as an asphalt rejuvenating agent and in-depth sealer. Satisfactory service shall be based on the capability of the material to decrease the viscosity of the asphalt binder and provide an in-depth seal. Reclamite®, manufactured by D&D Emulsion, Inc., Mansfield, Ohio, is a product of know quality and accepted performance.

The bidder must submit with his bid the manufacturer's certification that the material proposed for use is in compliance with the specification requirements. The bidder must submit with his bid previous use documentation and test data conclusively demonstrating that; the rejuvenating agent has been used successfully for a period of five years by government agencies such as Cities, Counties, etc; and that the asphalt rejuvenating agent has been proven to perform, as heretofore required, through field testing by government agencies as to the required change in asphalt binder viscosity. Testing data shall be submitted indicating such

product performance on a sufficient number of projects to insure product consistency. In addition, testing data shall be submitted to indicate said product performance over a testing period of three years to insure reasonable life expectancy.

RECLAMITE®, a product of Golden Bear Oil, a division of Tricor Refining, LLC. is a product of known quality and accepted performance.

#### **IV. Applicator Experience:**

The asphalt-rejuvenating agent shall be applied by an experienced applicator of such material. The bidder shall have a minimum of three years experience in applying the product proposed for use. He must submit with his bid a list of five projects on which he applied said rejuvenator. He shall indicate the project dates, number of square yards treated in each and the name and phone number of the government official in charge of each project.

A project superintendent knowledgeable and experienced in application of the asphalt-rejuvenating agent must be in control of each day's work. The bidder shall submit a written experience outline of the project superintendent.

#### **V. PRODUCT STANDARDS AND ALTERNATES:**

The product "Reclamite"® for the asphalt rejuvenating agent as manufactured by Golden Bear oil, a division of Tricor Refining, LLC. is the standard for these specifications and the prices quoted on the Bid Sheet Base Bid shall be for this standard. Should a bidder wish to submit a bid for alternates to the Standard, said prices shall be entered on the BID SHEET as the "Alternate Bid" for each item. In the event that the bidder submits no bid for the Standard, only the "Alternate Bids" should be completed.

Bidders may offer an ALTERNATE for the Standard specified in the Specifications provided the bidder adheres to the following and submits same with his bid.

(a) List the proposed alternate on the BID SHEET form giving the product name and price.

(b) Furnish complete specifications and descriptive literature for the alternate as well as a one-gallon sample of the material proposed for use. Such descriptive and detailed information shall be complete and at least equal in detail to the agencies requirements for the standard item for which the alternate is offered.

(c) Submit a current Material Safety Data Sheet for the alternate materials. The agency will give the alternate consideration. The Contractor may furnish only those alternate items included in his proposal and approved by the agency prior to award of a contract.

(d) Furnish all required test data and use documentation as hereto for required.

If no ALTERNATE is indicated on the BID SHEET, the Contractor shall furnish the STANDARD (brand) specified in the attached specifications. Should the ALTERNATE offered be found unacceptable by the agency based on the data submitted with the bid and no bid is entered on the BID SHEET for the Standard, then said bid will be considered non-responsive.

**VI. APPLICATION TEMPERATURE/WEATHER LIMITATIONS:**

The temperature of the asphalt rejuvenating emulsion, at the time of application shall be as recommended by the manufacturer. The asphalt-rejuvenating agent shall be applied only when the existing surface to be treated is thoroughly dry and when it is not threatening to rain. The asphalt-rejuvenating agent shall not be applied when the ambient temperature is below 40° F.

**VII. HANDLING OF ASPHALT REJUVENATING AGENT:**

Contents in tank cars or storage tanks shall be circulated at least forty-five minutes before withdrawing any material for application. When loading the distributor, the asphalt rejuvenating agent concentrate shall be loaded first and then the required amount of water shall be added. The water shall be added into the distributor with enough force to cause agitation and thorough mixing of the two materials. To prevent foaming, the discharge end of the water hose or pipe shall be kept below the surface of the material in the distributor that shall be used as a spreader. The distributor truck will be cleaned of all of its asphalt materials, and washed out to the extent that no discoloration of the emulsion may be perceptible. Cleanliness of the spreading equipment shall be subject to the approval and satisfaction of the Engineer.

**VIII. RESIDENT NOTIFICATION:**

The contractor shall distribute by hand, a typed notice to all residences and businesses on the street to be treated. The notice will be delivered no more than 24 hours prior to the treatment of the road. The notice will have a local phone number that residents may call to ask questions. The notice shall be of the door hanger type that secures to the door handle of each dwelling. Unsecured notices will not be allowed. The contractor shall also place the notice on the windshield of any parked cars on the street. Hand distribution of this notice will be considered incidental to the contract.

**IX. APPLICATING EQUIPMENT:**

The distributor for spreading the emulsion shall be self-propelled, and shall have pneumatic tires. The distributor shall be designed and equipped to distribute the asphalt rejuvenating agent uniformly on variable widths of surface at readily determined and controlled rates from 0.05 to 0.5 gallons per square yard of surface, and with an allowable variation from any specified rate not to exceed 5 percent of the specified rate.

Distributor equipment shall include full circulation spray bars, pump tachometer, volume measuring device and a hand hose attachment suitable for application of the emulsion manually to cover areas inaccessible to the distributor. The distributor shall be equipped to circulate and agitate the emulsion within the tank. The distributor shall have a computerized system, acceptable to the Engineer that controls the rate of product application.

A check of distributor equipment as well as application rate accuracy and uniformity of distribution shall be made when directed by the Engineer.

The truck used for applying slag screenings, or other aggregate approved by the Engineer, shall be equipped with a spreader that allows the slag screenings to be uniformly distributed onto the pavement. The spreader shall be able to apply 1/2 pound to 3 pounds of slag screenings per square yard in a single pass. The spreader shall be adjustable so as not to broadcast the slag screenings onto driveways or

tree lawns.

The slag screenings to be used shall be free flowing, without any leaves, dirt, stones, etc. Any wet slag screenings shall be rejected from the job site.

Any equipment that is not maintained in full working order, or is proven inadequate to obtain the results prescribed, shall be repaired or replaced at the direction of the Engineer.

#### **X. APPLICATION OF REJUVENATING AGENT:**

The asphalt-rejuvenating agent shall be applied by a distributor truck at the temperature recommended by the manufacturer and at the pressure required for the proper distribution. The emulsion shall be so applied that uniform distribution is obtained at all points of the areas to be treated. Distribution shall be commenced with a running start to insure full rate of spread over the entire area to be treated. Areas inadvertently missed shall receive additional treatment as may be required by hand sprayer application.

Application of asphalt rejuvenating agent shall be on one-half width of the pavement at a time. When the second half of the surface is treated, the distributor nozzle nearest the center of the road shall overlap the previous application by at least one-half the width of the nozzle spray. In any event the centerline construction joint of the pavement shall be treated in both application passes of the distributor truck.

Before spreading, the asphalt rejuvenating agent shall be blended with water at the rate of two (2) parts rejuvenating agent to one (1) part water, by volume or as specified by the manufacturer for jobsite conditions. The combined mixture of asphalt rejuvenating agent and water shall be spread at the rate of 0.05 to 0.10 gallons per square yard, or as approved by the Engineer following field testing.

Where more than one application is to be made, succeeding applications shall be made as soon as penetration of the preceding application has been completed and the Engineer grants approval for additional applications.

Grades or super elevations of surfaces that may cause excessive runoff, in the opinion of the Engineer, shall have the required amounts applied in two or more applications as directed.

After the rejuvenating emulsion has penetrated, a light coating of dry slag screenings, or other aggregate approved by the Engineer, shall be applied to the surface in sufficient amount to protect the traveling public as required by the Engineer. The slag screenings shall be swept and removed from the streets and properly disposed of at the Contractor's expense within 24 hours of application.

The Contractor shall furnish a quality inspection report showing the source, manufacturer, and the date shipped, for each load of asphalt rejuvenating agent. When directed by the Engineer, the Contractor shall take representative samples of material for testing.

#### **XI. STREET SWEEPING:**

The Contractor shall be responsible for sweeping and cleaning of the streets prior to, and after treatment.



Prior to treatment, the street will be cleaned of all standing water, dirt, leaves, foreign materials, etc. This work shall be accomplished by hand brooming, power blowing or other approved methods. If in the opinion of the Engineer the hand cleaning is not sufficient than a self-propelled street sweeper shall be used.

All slag screenings used during the treatment must be removed no later than 24 hours after treatment of the street. This shall be accomplished by a combination of hand and mechanical sweeping. All turnouts, cul-de-sacs, etc. must be cleaned of any material to the satisfaction of the Engineer. Street sweeping will be included in the price bid per square yard for asphalt rejuvenating agent.

If, in the opinion of the Engineer, additional slag screenings is required said material shall be applied by the contractor. Said slag screenings shall be swept up no later than 24 hours following reapplication. No additional compensation will be allowed for reapplication and removal of slag screenings.

**XII. TRAFFIC CONTROL:**

The Contractor shall schedule his operations and carry out the work in a manner to cause the least disturbance and/or interference with the normal flow of traffic over the areas to be treated. Treated portions of the pavement surfaces shall be kept closed and free from traffic until penetration, in the opinion of the Engineer, has become complete and the area is suitable for traffic.

When, in the opinion of the Engineer, traffic must be maintained at all times on a particular street, then the Contractor shall apply asphalt rejuvenating agent to one lane at a time. Traffic shall be maintained in the untreated lane until the traffic may be switched to the completed lane.

The Contractor shall be responsible for all traffic control and signing required to permit safe travel. The contractor shall notify the police and fire departments as to the streets that are to be treated each day.

If, in the opinion of the Engineer, proper signing is not being used, the Contractor shall stop all operations until safe signing and barricading is achieved.

**XIII. METHOD OF MEASUREMENT:**

Asphalt rejuvenating agent will be measured by the square yard as provided for in the Contract Documents.

**XIV. BASIS FOR PAYMENT:**

The accepted quantities, measured as provided for above, will be paid for at the contract unit price for asphalt rejuvenating agent.

Asphalt rejuvenating agent shall be paid for PER SQUARE YARD, which shall be full compensation for furnishing all materials; equipment, labor and incidentals to complete the work as specified and required.

---

# Appendix B

---

## Prevailing Wage

# Prevailing Wage Contract

**2018 STREET PROGRAM, ST-1054**

Yes (x)      No ( )

If yes, current prevailing wages are included as part of this appendix.  
(Current wage rates are located on an enclosed CD-ROM. Please request a hard copy from the City if needed.)

## STATE OF OHIO REQUEST FOR PREVAILING WAGE RATES

**Important:** If you wish to retain a copy of this form for your records, please print it prior to clicking on the "Submit" button. When you click the "Submit" button, a prompt should appear which will allow you to obtain the necessary wage rates by clicking on the "view wage rates" button. Submitting this form notifies the Bureau of Labor and Worker Safety of your project. Wage rates will not be sent to you by mail as a result of the submission, rather you should obtain them by clicking on the "view wage rates" button.

### Public Authority Information

<b>Owner/Public Authority Name:</b>	City of Gahanna	<b>Date: 02/21/2018</b> This form must be filled out completely & correctly for us to process your request. Forms not completed correctly will be returned to the sender.
<b>Department Division or Agency:</b>	Engineering	
<b>Street Address:</b>	200 S. Hamilton Rd.	ODOC Date Stamp
<b>Address 2:</b>		
<b>City, OH</b>	Gahanna	
<b>ZIP:</b>	43230	
<b>Email:</b>	jill.webb@gahanna.gov It is required that you list your e-mail address here.	
<b>County of Public Authority:</b>	FRANKLIN ▼	
<b>P.A. Phone:</b>	6143424050	

### Project Information

<b>Project Name:</b>	2018 Street Program ST-1054	ODOC Date Stamp (Bld Tab)
<b>Site Address:</b>	Various locations throughout Gahanna	
<b>City, OH</b>	Gahanna, OH	
<b>ZIP:</b>	43230	
<b>County of Project:</b>	FRANKLIN ▼	
<b>Prevailing Wage Coordinator Name</b>	Jill Webb	
<b>Address:</b>	200 S. Hamilton Rd.	
<b>City,</b>	Gahanna	
<b>ZIP:</b>	43230	
<b>Phone:</b>	6143424050	
<b>Issuing Authority of Bonds:</b>		
<b>Estimated Total Overall Project Cost:</b>	\$3,629,520.00	
<b>Type of Financing:</b>	Local Funds	
<b>Type of Construction:</b>	<input type="radio"/> New Construction <input checked="" type="radio"/> Old Construction	
<b>This Project is</b>	<input type="radio"/> Residential <input checked="" type="radio"/> Commercial	

Expected Date of Contract Award:	04/09/18 example 05/31/98
Projected Completion Date:	08/14/18 example 05/31/98
Project Comments:	  (optional)

**Important:** If you wish to retain a copy of this form for your records, please print it prior to clicking on the "Submit" button. When you click the "Submit" button, a prompt should appear which will allow you to obtain the necessary wage rates by clicking on the "view wage rates" button. Submitting this form notifies the Bureau of Labor and Worker Safety of your project. Wage rates will not be sent to you by mail as a result of the submission, rather you should obtain them by clicking on the "view wage rates" button.

Please contact our Webmaster with questions or comments.

LAW 1002



- ▶ forms
- ▶ contacts
- ▶ about LAWS
- ▶ search

## Ohio Department of Commerce Bureau of Wage & Hour Administration

[Consumers](#)
[Business](#)
[License/Permit Holders & Applicants](#)
[Other Government Agencies](#)

[Back to wage rate search](#) [Back to Home](#)

**Classification = All, County = FRANKLIN, Union = All**

County	Classification	Effective	Posted	Union
FRANKLIN	Asbestos Worker	10/4/2017	10/4/2017	Asbestos Local 207 OH
FRANKLIN	Asbestos Worker	7/26/2017	7/26/2017	Asbestos Local 50 Zone 1
FRANKLIN	Boilermaker	10/1/2013	9/25/2013	Boilermaker Local 105
FRANKLIN	Bricklayer	6/1/2017	5/31/2017	Bricklayer Local 55
FRANKLIN	Bricklayer	6/1/2017	5/31/2017	Bricklayer Local 55 Tile Setter
FRANKLIN	Bricklayer	6/1/2017	5/31/2017	Bricklayer Local 55 Tile & Marble Finisher
FRANKLIN	Carpenter	5/2/2017	5/2/2017	Carpenter Millwright Local 1090 Columbus
FRANKLIN	Carpenter	3/5/2014	3/5/2014	Carpenter NE District Industrial Dock & Door
FRANKLIN	Carpenter	5/2/2017	5/2/2017	Carpenter & Pile Driver Local 200
FRANKLIN	Carpenter	6/7/2017	6/7/2017	Carpenter & Piledriver SC District HevHwy
FRANKLIN	Bricklayer	6/1/2017	5/31/2017	Cement Mason Bricklayer Local 97 HevHwy A
FRANKLIN	Bricklayer	6/1/2017	5/31/2017	Cement Mason Bricklayer Local 97 HevHwy B
FRANKLIN	Cement	7/26/2017	7/26/2017	Cement Mason Local 132 (Columbus)
FRANKLIN	Cement Mason	5/24/2017	5/24/2017	Cement Mason Statewide HevHwy Exhibit A District III
FRANKLIN	Cement Mason	5/24/2017	5/24/2017	Cement Mason Statewide HevHwy Exhibit B District III
FRANKLIN	Electrical	1/31/2018	1/31/2018	Electrical Local 683 Inside
FRANKLIN	Electrical	1/31/2018	1/31/2018	Electrical Local 683 Inside Lt Commercial South West
FRANKLIN	Voice Data Video	6/7/2017	6/7/2017	Electrical Local 683 Voice Data Video
FRANKLIN	Lineman	5/24/2017	5/24/2017	Electrical Local 71 High Tension Pipe Type Cable
FRANKLIN	Lineman	3/10/2016	3/10/2016	Electrical Local 71 Outside Utility Power
FRANKLIN	Lineman	3/29/2017	3/29/2017	Electrical Local 71 Outside (Central OH Chapter)
FRANKLIN	Voice Data Video	10/18/2017	10/18/2017	Electrical Local 71 Voice Data Video Outside
FRANKLIN	Elevator	1/31/2018	1/31/2018	Elevator Local 37
FRANKLIN	Glazier	11/8/2017	11/8/2017	Glazier Local 372
FRANKLIN	Ironworker	6/1/2017	5/31/2017	Ironworker Local 172
FRANKLIN	Laborer Group 1	5/1/2017	4/5/2017	Labor HevHwy 3
FRANKLIN	Laborer	7/19/2017	7/19/2017	Labor Local 423
FRANKLIN	Operating Engineer	8/2/2017	8/2/2017	Operating Engineers - Building Local 18 - Zone III
FRANKLIN	Operating Engineer	8/2/2017	8/2/2017	Operating Engineers - HevHwy Zone II
FRANKLIN	Drywall Finisher	9/14/2017	9/14/2017	Painter Local 1275
FRANKLIN	Painter	11/1/2017	11/1/2017	Painter Local 1275
FRANKLIN	Painter	11/1/2017	11/1/2017	Painter Local 1275 HevHwy
FRANKLIN	Painter	11/1/2017	11/1/2017	Painter Local 1275 Industrial
FRANKLIN	Painter	6/10/2015	6/10/2015	Painter Local 639
FRANKLIN	Painter	8/3/2016	8/3/2016	Painter Local 639 Zone 2 Sign
FRANKLIN	Plasterer	7/26/2017	7/26/2017	Plasterer Local 132 (Columbus)
FRANKLIN	Plumber Pipefitter	6/7/2017	6/7/2017	Plumber Pipefitter Local 189
FRANKLIN	Roofer	11/8/2017	11/8/2017	Roofer Local 86
FRANKLIN	Sheet Metal Worker	8/2/2017	8/2/2017	Sheet Metal Local 24 Columbus
FRANKLIN	Sprinkler Fitter	1/10/2018	1/10/2018	Sprinkler Fitter Local 669
FRANKLIN	Truck Driver	7/5/2017	7/5/2017	Truck Driver Bldg & HevHwy Class 1 Locals 20,40,92,92b,100,175,284,438,377,637,908,957
FRANKLIN	Truck Driver	7/5/2017	7/5/2017	Truck Driver Bldg & HevHwy Class 2 Locals 20,40,92,92b,100,175,284,438,377,637,908,957

[Back to home](#)

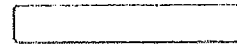
**INDUSTRIAL COMPLIANCE**
**SECTIONS**
**RESOURCES**
**CONTACT US**

## INSTRUCTIONS FOR PREPARING CERTIFIED PAYROLL REPORTS

### General

Contractors and subcontractors are required by law to submit certified payroll reports for work on projects covered by Ohio's Prevailing Wage Law. This form meets the reporting requirements established by Ohio Revised Code Chapter 4115. The use of this form is not mandatory, employers may submit their own forms provided that all of the required information is included. This form may be reproduced, or additional copies obtained from:

Ohio Department of Commerce Division of Industrial Compliance and Labor Bureau of Wage & Hour Administration 6606 Tussing Rd. P. O. Box 4009 Reynoldsburg, OH 43068-9009 Phone: (614) 644-2239

### Certified Payroll Heading

Employer name and address: Company's full name and address. Indicate if the company is a subcontractor, if so list the name of the General or Prime. Project: Name and location of the project, including county. Contracting Public Authority: Name and address of the contracting public authority. Week Ending: Month, day, and year for last day of reporting period. Payroll #: Indicates first, second, third, etc. payroll filed by the company for the project. Page indicator: number of pages included in the report. Project Number: Determined by the public authority. If there is no number leave blank.

### Information by Column

- 1. Employee Name, Address and Social Security number: This information must be provided for all employees that perform physical labor on the project. Corporate officers, partners, and salaried employees are considered employees and must be paid the prevailing rate. Individual sole proprietors do not have to pay themselves prevailing rate but must report their hours on the project.
- 2. Work Class: List classification of work actually performed by employee. If unsure of work classification, consult the Ohio department of Commerce, Wage and Hour Bureau. Employees working more than one classification should have separate line entries for each classification. Indicate what year/level for Apprentices. Be specific when using laborer and operator classifications; for example, Backhoe Operator or Asphalt Laborer.
- 3. Hours Worked, Day & Date: In the first row of column 3 enter days of pay period example; M T W T H F S S. The second row is for the date that corresponds with each day for the pay period. In the employee information section enter the number of hours worked on the prevailing wage project and which day the hours were worked. Separate rows are labeled for (ST) straight time hours and (OT) overtime hours. All hours worked after 40, must be paid at the appropriate overtime rate.
- 4. Project Total Hours: Total the hours entered for pay period.
- 5. Base Rate: Enter actual rate per hour paid to the employee. The overtime hourly rate is time and one-half the base rate listed in the prevailing wage schedule plus fringe benefits at straight time rate. The prevailing wage schedule lists the base rate plus fringe benefit amounts. These amounts added together equal the total prevailing wage rate. Employers must pay this total amount in one of three ways.
  - Total rate may be paid in entirety in the base rate to the employee; in which case, the cash designation will be checked for fringe benefits.
  - Total rate may be paid as listed in prevailing wage rate schedule with total fringe amounts paid approved plans.
  - Total rate may be paid with a combination of base rate and fringe payments to approved plans in amounts other than those listed in schedule.
- 6. Project Gross: Enter total gross wages earned on the project for straight time and overtime. Project hours X base rate should equal project gross.
- 7. Fringes: If fringe benefits are paid in the hourly base rate, indicate this by marking the cash space. If fringe benefits are paid to approved plans as listed in the prevailing wage rate schedule, mark the space Approved Plans. If fringe benefits are paid partially in the base rate and partially to approved plans, mark the space Cash & Approved plans. List the hourly amount paid to approved plans for each fringe. If payments are not made on a per hour basis, calculate the hourly fringe credit by dividing the yearly employer contribution by the lesser of: hours actually worked in the year (these must be documented) or 2080. Fringe benefits include: Employer's share of health insurance, life insurance, retirement plan, bonus/profit sharing, sick pay, holiday pay, personal leave, vacation, and education/training programs.
- 8. Total Hours All Jobs: Total all hours worked during the pay period including non-prevailing wage jobs.
- 9. Total Gross All Jobs: Gross amount earned in the pay period for all hours worked.
- 10. Self explanatory.
- 11. Self explanatory.
- 12. Self explanatory.



**Department  
of Commerce**

Division of Industrial Compliance

John R. Kasich, Governor  
Jacqueline T. Williams, Director

Bureau of Wage and Hour Administration  
6606 Tussing Road - PO Box 4009  
Reynoldsburg, OH 43608-9009  
Phone 614-644-2239 | Fax 614-728-8639  
TTY/TDD 800-750-0750  
com.ohio.gov

An Equal Opportunity Employer and Service Provider

**PREVAILING WAGE CONTRACTOR RESPONSIBILITIES**

**This is a summary of prevailing wage contractors' responsibilities. For more detailed information please refer to Chapter 4115 of the Ohio Revised Code**

**General Information**

Ohio's prevailing wage laws apply to all public improvements financed in whole or in part by public funds when the total overall project cost is fairly estimated to be more than \$250,000 for new construction or \$75,000 for reconstruction, enlargement, alteration, repair, remodeling, renovation, or painting.

Ohio's prevailing wage laws apply to all public improvements financed in whole or in part by public funds when the total overall project cost is fairly estimated to be more than \$91,150 for new construction that involves roads, streets, alleys, sewers, ditches and other works connected to road or bridge construction or \$27,309 for reconstruction, enlargement, alteration, repair, remodeling, renovation, or painting of a public improvement that involves roads, streets, alleys, sewers, ditches and other works connected to road or bridge construction.

- a) Thresholds are to be adjusted biennially by the Administrator of Ohio Department of Commerce, Division of Industrial Compliance and Labor, Bureau of Wage and Hour Administration
- b) Biennial adjustments to threshold levels are made according to the Price Deflator for Construction Index, United States Department of Commerce, Bureau of the Census\*, but may not increase or decrease more than 3% for any year

**Penalties for violation**

Violators are to be assessed the wages owed, plus a penalty of 100% of the wages owed.

**Intentional Violations**

If an intentional violation is determined to have occurred, the contractor is prohibited from contracting directly or indirectly with any public authority for the construction of a public improvement. Intentional violation means "a willful, knowing, or deliberate disregard for any provision" of the prevailing wage law and includes but is not limited to the following actions:

- Intentional failure to submit payroll reports as required, or knowingly submitting false or erroneous reports.
- Intentional misclassification of employees for the purpose of reducing wages.
- Intentional misclassification of employees as independent contractors or as apprentices.
- Intentional failure to pay the prevailing wage.
- Intentional failure to comply with the allowable ratio of apprentices to skilled workers as required by the regulations established by Ohio Department of Commerce, Division of Industrial Compliance and Labor, Bureau of Wage and Hour Administration.
- Intentionally employing an officer, of a contractor or subcontractor, that is known to be prohibited from contracting, directly or indirectly, with a public authority.

**Responsibilities**

- A. Pay the prevailing rate of wages as shown in the wage rate schedules issued by the Ohio Department of Commerce, Division of Industrial Compliance and Labor, Bureau of Wage and Hour Administration, for the classification of work being performed.
  1. Wage rate schedules include all modifications, corrections, escalations, or reductions to wage rates issued for the project.



2. Overtime must be paid at time and one-half the employee's base hourly rate. Fringe benefits are paid at straight time rate for all hours including overtime.
  3. Prevailing wages must be paid in full without any deduction for food, lodging, transportation, use of tools, etc.; unless, the employee has voluntarily consented to these deductions in writing. The public authority and the Director of Ohio Department of Commerce, Division of Industrial Compliance and Labor, Bureau of Wage and Hour Administration - must approve these deductions as fair and reasonable. Consent and approval must be obtained before starting the project.
- B. Use of Apprentices and Helpers cannot exceed the ratios permitted in the wage rate schedules.
1. Apprentices must be registered with the U.S. Department of Labor Bureau of Apprenticeship and Training.
  2. Contractors must provide the Prevailing Wage Coordinator a copy of the Apprenticeship Agreement for each apprentice on the project.
- C. Keep full and accurate payroll records available for inspection by any authorized representative of the Ohio Department of Commerce, Division of Industrial Compliance, and Labor, Bureau of Wage and Hour Administration or the contracting public authority, including the Prevailing Wage Coordinator. Records should include but are not limited to:
1. Time cards, time sheets, daily work records, etc.
  2. Payroll ledger/journals and canceled checks/check register.
  3. Fringe benefit records must include program, address, account number, & canceled checks.
  4. Records made in connection with the public improvement must not be removed from the State for one year following the completion of the project.
  5. Out-of-State Corporations must submit to the Ohio Secretary of State the full name and address of their Statutory Agent in Ohio.
- D. Prevailing Wage Rate Schedule must be posted on the job site where it is accessible to all employees.
- E. Prior to submitting the initial payroll report, supply the Prevailing Wage Coordinator with your project dates to schedule reporting of your payrolls.
- F. Supply the Prevailing Wage Coordinator a list of all subcontractors including the name, address, and telephone number for each.
1. **Contractors are responsible for their subcontractors' compliance with requirements of Chapter 4115 of the Ohio Revised Code.**
- G. Before employees start work on the project, supply them with written notification of their job classification, prevailing wage rate, fringe benefit amounts, and the name of the Prevailing Wage Coordinator for the project. A copy of the completed signed notification should be submitted to Prevailing Wage Coordinator.
- H. Supply all subcontractors with the Prevailing Wage Rates and changes.
- I. Submit certified payrolls within two (2) weeks after the initial pay period. Payrolls must include the following information:
1. Employees' names, addresses, and social security numbers.
    - (a) Corporate officers/owners/partners and any salaried personnel who do physical work on the project are considered employees. All rate and reporting requirements are applicable to these individuals.
  2. Employees' work classification.
    - (a) Be specific about the laborers and/or operators (Group)
    - (b) For all apprentices, show level/year and percent of journeyman's rate
  3. Hours worked on the project for each employee.

- (a) The number of hours worked in each day and the total number of hours worked each week.
  4. Hourly rate for each employee.
    - (a) The minimum rate paid must be the wage rate for the appropriate classification. The Department's Wage Rate Schedule sets this rate.
    - (b) All overtime worked is to be paid at time and one-half for all hours worked more than forty (40) per week.
  5. Where fringes are paid into a bona fide plan instead of cash, list each benefit and amount per hour paid to program for each employee.
    - (a) When the amount contributed to the fringe benefit plan and the total number of hours worked by the employee on all projects for the year are documented, the hourly amount is calculated by dividing the total contribution of the employer by the total number of hours worked by the employee.
    - (b) When the amount contributed to the fringe benefit is documented but not the total hours worked, the hourly amount is calculated by **dividing the total yearly contribution by 2080**.
  6. Gross amount earned on all projects during the pay period.
  7. Total deductions from employee's wages.
  8. Net amount paid.
- J. The reports shall be certified by the contractor, subcontractor, or duly appointed agent stating that the payroll is correct and complete; and that the wage rates shown are not less than those required by the O.R.C. 4115.
- K. Provide a Final Affidavit to the Prevailing Wage Coordinator upon the completion of the project.

## Prevailing Wage Determination Cover Letter

County:  ▼  
Determination Date: 02/21/2018  
Expiration Date: 05/21/2018

THE FOLLOWING PAGES ARE PREVAILING RATES OF WAGES ON PUBLIC IMPROVEMENTS FAIRLY ESTIMATED TO BE MORE THAN THE AMOUNT IN O.R.C. SEC. 4115.03 (b) (1) or (2), AS APPLICABLE.

Section 4115.05 provides, in part: "Where contracts are not awarded or construction undertaken within ninety days from the date of the establishment of the prevailing wages, there shall be a redetermination of the prevailing rate of wages before the contract is awarded." The expiration date of this wage schedule is listed above for your convenience only. This wage determination is not intended as a blanket determination to be used for all projects during this period without prior approval of this Department.

Section 4115.04, Ohio Revised Code provides, in part: "Such schedule of wages shall be attached to and made a part of the specifications for the work, and shall be printed on the bidding blanks where the work is done by contract..."

The contract between the letting authority and the successful bidder shall contain a statement requiring that mechanics and laborers be paid a prevailing rate of wage as required in Section 4115.06, Ohio Revised Code.

The contractor or subcontractor is required to file with the contracting public authority upon completion of the project and prior to final payment therefore an affidavit stating that he has fully complied with Chapter 4115 of the Ohio Revised Code.

The wage rates contained in this schedule are the "Prevailing Wages" as defined by Section 4115.03, Ohio Revised Code (the basic hourly rates plus certain fringe benefits). These rates and fringes shall be a minimum to be paid under a contract regulated by Chapter 4115 of the Ohio Revised Code by contractors and subcontractors. The prevailing wage rates contained in this schedule include the effective dates and wage rates currently on file. In cases where future effective dates are not included in this schedule, modifications to the wage schedule will be furnished to the Prevailing Wage Coordinator appointed by the public authority as soon as prevailing wage rates increases are received by this office.

"There shall be posted in a prominent and accessible place on the site of work a legible statement of the Schedule of Wage Rates specified in the contract to the various classifications of laborers, workmen, and mechanics employed, said statement to remain posted during the life of such contract." Section 4115.07, Ohio Revised Code.

Apprentices will be permitted to work only under a bona fide apprenticeship program if such program exists and if such program is registered with the Ohio Apprenticeship Council.

Section 4115.071 provides that no later than ten days before the first payment of wages is due to any employee of any contractor or subcontractor working on a contract regulated by Chapter 4115, Ohio Revised Code, the contracting public authority shall appoint one of his own employees to act as the prevailing wage coordinator for said contract. The duties of the prevailing wage coordinator are outlined in Section 4115.071 of the Ohio Revised Code.

Section 4115.05 provides for an escalator in the prevailing wage rate. Each time a new rate is established, that rate is required to be paid on all ongoing public improvement projects.

A further requirement of Section 4115.05 of the Ohio Revised Code is: "On the occasion of the first pay date under a contract, the contractor shall furnish each employee not covered by a collective bargaining agreement or understanding between employers and bona fide organizations of Labor with individual written notification of the job classification to which the employee is assigned, the prevailing wage determined to be applicable to that classification, separated into the hourly rate of pay and the fringe payments, and the identity of the prevailing wage Coordinator appointed by the public authority. The contractor or subcontractor shall furnish the same notification to each affected employee every time the job classification of the employee is changed."

Work performed in connection with the installation of modular furniture may be subject to prevailing wage.

**THIS PACKET IS NOT TO BE SEPARATED BUT IS TO REMAIN COMPLETE AS IT IS SUBMITTED TO YOU. (Reference guidelines and forms are included in this packet to be helpful in the compliance of the Prevailing Wage law.)**  
wh1500

# PREVAILING WAGE THRESHOLD LEVELS IMPORTANT NOTICE

Before advertising for bids, contracting, or undertaking construction with its own forces, to construct a public improvement, the Public Authority shall have the Ohio Department of Commerce-Division of Industrial Compliance, Bureau of Wage and Hour Administration determine the prevailing rates of wages for workers employed on the public improvement. The wage determination must be included in the project specifications and printed on the bidding blanks where work is done by contract.

<b>“New” construction threshold for <i>Building Construction</i>:</b>	<b>\$250,000</b>
---	------------------

<b>“Reconstruction, enlargement, alteration, repair, remodeling, renovation, or painting” threshold level for <i>Building Construction</i>:</b>	<b>\$75,000</b>
---	-----------------

<b>As of January 1, 2018:</b>	
<b>“New” construction that involves <i>roads, streets, alleys, sewers, ditches and other works connected to road or bridge construction</i> threshold level has been adjusted to:</b>	<b>\$91,150</b>

<b>“Reconstruction, enlargement, alteration, repair, remodeling, renovation, or painting” that involves <i>roads, streets, alleys, sewers, ditches and other works connected to road or bridge construction</i> threshold level has been adjusted to:</b>	<b>\$27,309</b>
---	-----------------

- A) Thresholds are to be adjusted biennially by the Director of the Ohio Department of Commerce.
- B) Biennial adjustments to threshold levels are made according to the Building Cost for Skilled Labor Index published by McGraw-Hill’s Engineering News-Record, but may not increase or decrease more than 3% for any year.

If there are questions concerning this notification, please contact:

Ohio Department of Commerce  
 Division of Industrial Compliance  
 Bureau of Wage and Hour Administration  
 6606 Tussing Road, PO Box 4009  
 Reynoldsburg, Ohio 43068-9009  
 Phone: 614-644-2239  
 Fax: 614-728-8639  
[www.com.ohio.gov](http://www.com.ohio.gov)



# Department of Commerce

Division of Industrial Compliance

Bureau of Wage and Hour Administration  
6606 Tussing Road - PO Box 4009  
Reynoldsburg, OH 43068-9009  
Phone 614-644-2239 | Fax 614-728-8639  
TTY/TDD 800-750-0750  
www.com.ohio.gov

An Equal Opportunity Employer and Service Provider

John R. Kasich, Governor  
Andre T. Porter, Director

## Affidavit Of Compliance

### PREVAILING WAGES

I, \_\_\_\_\_  
(Name of person signing affidavit) (Title)

do hereby certify that the wages paid to all employees of

\_\_\_\_\_  
(Company Name)

for all hours worked on the

\_\_\_\_\_  
(Project name and location)

project, during the period from \_\_\_\_\_ to \_\_\_\_\_ are in  
(Project Dates)

compliance with prevailing wage requirements of Chapter 4115 of the Ohio Revised Code. I further certify that no rebates or deductions have been or will be made, directly or indirectly, from any wages paid in connection with this project, other than those provided by law.

\_\_\_\_\_  
(Signature of Officer or Agent)

Sworn to and subscribed in my presence this \_\_\_\_\_ day of \_\_\_\_\_,  
20\_\_\_\_\_.

\_\_\_\_\_  
(Notary Public)

The above affidavit must be executed and sworn to by the officer or agent of the contractor or subcontractor who supervises the payment of employees. This affidavit must be submitted to the owner (public authority) before the surety is released or final payment due under the terms of the contract is made.



- ▶ forms
- ▶ contacts
- ▶ about LAWS
- ▶ search

## Ohio Department of Commerce Bureau of Wage & Hour Administration

[Consumers](#)[Business](#)[License/Permit Holders & Applicants](#)[Other Government Agencies](#)

### Submitting Union Contract Information

The Ohio Department of Commerce, Bureau of Wage & Hour, will no longer take union contract information for the establishment of prevailing wage rates via the web. The majority of information from the unions submitted in this manner was not supported with an associated mailing of the actual union contract and an affidavit as required. The Bureau will continue to make every effort to post up to date wage rates as efficiently as possible. In order to do so, those submitting information to the Bureau on behalf of the unions must:

- 1) submit contract information in a timely manner via fax, regular US Mail, or other non-electronic method
- 2) contract information submitted must be the actual signed union contract

Please send the appropriate information to:

Bureau of Wage & Hour  
Attn: Kathy Peck  
6606 Tussing Road, P.O. Box 4009  
Reynoldsburg, Ohio 43068-9009

[commerce home](#) / [forms](#) / [contacts](#) / [press room](#) / [feedback](#) / [privacy policy](#)

# **Appendix C**

---

## **Bid Documents**

THE AMERICAN INSTITUTE OF ARCHITECTS

AIA Document A305

Contractor's Qualification Statement

1986 EDITION

This form is approved and recommended by The American Institute of Architects (AIA) and The Associated General Contractors of America (AGC) for use in evaluating the qualifications of contractors. No endorsement of the submitting party or verification of the information is made by the AIA or AGC.

The Undersigned certifies under oath that the information provided herein is true and sufficiently complete so as not to be misleading.

SUBMITTED TO: City of Gahanna

ADDRESS: 200 South Hamilton Road
Gahanna, OH 43230

SUBMITTED BY: Decker Construction Company Corporation
NAME: Carl W. Scheiderer Partnership
ADDRESS: 3040 McKinley Avenue Individual
PRINCIPAL OFFICE: Columbus, Ohio 43204 Joint Venture
Other

NAME OF PROJECT (if applicable): 2018 Street Program, ST-1054

TYPE OF WORK (file separate form for each Classification of Work):

General Construction HVAC
Plumbing Electrical
X Other Asphalt Paving, Stone Paving, Site Concrete
(please specify)

Copyright 1964, 1969, 1979, (C)1986 by The American Institute of Architects, 1735 New York Avenue, N.W., Washington, D.C. 20006. Reproduction of the material herein or substantial quotation of its provisions without permission of the AIA violates the copyright laws of the United States and will be subject to legal prosecution.



1. ORGANIZATION

1.1 How many years has your organization been in business as a Contractor?

**Thirty-Seven (37)**

1.2 How many years has your organization been in business under its present business name?

**Thirty-Seven (37)**

1.2.1 Under what other or former names has your organization operated?

**N/A**

1.3 If your organization is a corporation, answer the following:

1.3.1 Date of incorporation: **March, 1980**

1.3.2 State of incorporation: **Ohio**

1.3.3 President's name: **Carl W. Scheiderer**

1.3.4 Vice-president's name(s):

1.3.5 Secretary's name: **Jonathan R. Apple**

1.3.6 Assistant Secretary=s name: **Carl W. Scheiderer**

1.3.6 Chairman of the Board: **Roger Apple**

1.4 If your organization is a partnership, answer the following:

1.4.1 Date of organization:

1.4.2 Type of partnership (if applicable):

1.4.3 Name(s) of general partner(s):

**N/A**

1.5 If your organization is individually owned, answer the following:

1.5.1 Date of organization:

1.5.2 Name of owner:

**N/A**

1.6 If the form of your organization is other than those listed above, describe it and name the principals:

**N/A**

## 2. LICENSING

- 2.1 List jurisdictions and trade categories in which your organization is legally qualified to do business, and indicate registration or license numbers, if applicable.

**Ohio**

**We primarily service the Central Ohio area which includes Franklin and surrounding counties.**

- 2.2 List jurisdictions in which your organization's partnership or trade name is filed.

**N/A**

## 3. EXPERIENCE

- 3.1 List the categories of work that your organization normally performs with its own forces.

**Stone and asphalt paving, site concrete work, site utilities and dirt work.**

- 3.2 Claims and Suits. (if the answer to any of the questions below is yes, please attach details.)

3.2.1 Has your organization ever failed to complete any work awarded to it?

**No.**

3.2.2 Are there any judgments, claims, arbitration proceedings or suits pending or outstanding against your organization or its officers?

**No.**

3.2.3 Has your organization filed any law suits or requested arbitration with regard to construction contracts within the last five years?

**No.**

- 3.3 Within the last five years, has any officer or principal of your organization ever been an officer or principal of another organization when it failed to complete a construction contract? (If the answer is yes, please attach details.)

**No.**

3.4 On a separate sheet, list major construction projects your organization has in progress, giving the name of project, owner, architect, contract amount, percent complete and scheduled completion date. **Exhibit A attached.**

3.4.1 State total worth in progress and under contract: **Approx. \$ 8,000,000**

3.5 On a separate sheet, list the major projects your organization has completed in the past five years, giving the name of project, owner, architect, contract amount, date of completion and percentage of the cost of the work performed with your own forces. **Exhibit B attached.**

3.5.1 State average annual amount of construction work performed during the past five years: **Approx. \$ 30,000,000.**

3.6 On a separate sheet, list the construction experience and present commitments of the key individuals of your organization.

**Roger Apple - 39 years with Decker Construction, Field Supervision.**

#### 4. REFERENCES

4.1 Trade References:

**Shelly Materials, 301 Frank Road, Columbus, OH 43207 - 614-445-1125 (Ted Lemmon)  
Anderson Concrete Corp., 400 Frank Rd., Columbus, OH 43207 -614-443-0123  
(Chad Higginbotham)  
Columbus Equipment, 50 E. Kingston Avenue, Columbus, OH 43207 - 614-443-6541**

4.2 Bank References:

**The Huntington National Bank  
250 Civic Center Drive, Suite 550, Columbus, OH 43215  
Ryan Yeater, V.P. Commercial Banking 614-480-3848**

4.3 Surety:

4.3.1 Name of bonding company:

**Cincinnati Insurance Company**

4.3.2 Name and address of agent:

**Ray Insurance Agency, 1580 Fishinger Road  
Columbus, OH 43221  
Joe Ray - 614-459-1122**

## 5. FINANCING

### 5.1 Financial Statement.

- 5.1.1 Attach a financial statement, preferably audited, including your organization's latest balance sheet and income statement showing the following items: **See NOTE below.**

Current Assets (e.g., cash, joint venture accounts, accounts receivable, notes receivable, accrued income, deposits, materials inventory and prepaid expenses):

Net Fixed Assets:

Other Assets:

Current Liabilities (e.g., accounts payable, accrued expenses, provision for income taxes, advances, accrued salaries and accrued payroll taxes:

Other liabilities (e.g., capital, capital stock, authorized and outstanding shares, par values, earned surplus and retained earnings):

- 5.1.2 Name and address of firm preparing attached financial statements, and date thereof:

- 5.1.3 Is the attached financial statement for the identical organization named on page one?

- 5.1.4 If not, explain the relationship and financial responsibility of the organization whose financial statement is provided (e.g., parent-subsidiary).

- 5.2 Will the organization whose financial statement is attached act as guarantor of the contract for construction?

**NOTE:** As a company policy, we do not release our financial statements, however, you may review our financial statements at our office or make inquiries to our bank and bonding company as to our financial strength.

6. SIGNATURE

6.1 Dated at Columbus, OH this 9<sup>th</sup> day of March 20 18.

Name of organization: **Decker Construction Company**

By:   
Carl W. Scheiderer

Title: President

6.2

**Mr. Carl W. Scheiderer** being duly sworn deposes and says that the information provided herein is true and sufficiently complete so as not to be misleading

Subscribed and sworn before me this 9<sup>th</sup> day of March 20 18.

Notary Public: Laura Ann Lombardi

My Commission Expires: 8-05-2020



**LAURA ANN LOMBARDI**  
NOTARY PUBLIC, STATE OF OHIO  
MY COMMISSION EXPIRES 8-05-2020

**EXHIBIT A**

<u>Owner</u>	<u>Project</u>	<u>Contract Amt.</u>	<u>% Complete</u>	<u>Completion Date</u>
City Upper Arlington	2014 Street Reconstruct	\$ 1,425,605	90	May, 2015
Columbia Gas of Ohio	Street Repairs	\$ 3,900,000	30	March, 2017
City of Columbus	2014 Street Resurfacing	\$ 2,536,111	90	June, 2015
Defense Finance/Acctg.	DSCC M & R FY 14	\$ 2,034,768	0	August, 2015

**EXHIBIT B**

<u>Owner</u>	<u>Project</u>	<u>Contract Amt.</u>	<u>% Completed w/ Our Forces</u>
ODOT	Numerous	\$ 5,000,000	100
City of Columbus	Numerous	\$ 9,000,000	100
Meijer	Numerous	\$ 5,000,000	100
Columbia Gas	Numerous	\$ 2,000,000	100
M/I Homes Central Ohio	Numerous	\$ 3,000,000	100
Dominion Homes	Numerous	\$ 3,000,000	100
City Upper Arlington	Numerous	\$ 4,000,000	100
City of Hilliard	Numerous	\$ 1,500,000	100



## SUBCONTRACTORS LIST

### 2018 STREET PROGRAM, ST-1054

The attention of bidders is directed, particularly to Section 0.42, page 34, of the General Conditions relative, respectively, to the requirements to sub-letting of assigning all or any portion of the work under this Contract.

The bidder is required to state, in detail, in the space provided below, the name, address, experience and the work to be performed by sub-contractors in this contract.

If no sub-contractors are to be used, so state.

Pavement Technology, Inc.	Griffin Pavement Striping
24144 Detroit Road	2383 Harrison Road
Westlake, Ohio 44145	Columbus, Ohio 43204
Reclamite Asphalt Rejuvenating Agent	Pavement markings

Danbert Construction Corp.	Complete General Construction Company
8077 Memorial Drive	1221 East Fifth Avenue
Plain City, Ohio 43064	Columbus, Ohio 43219
water line	RCC, saw & seal Asphalt over control joints

Bituminous Pavement Systems	Phenix Stabilization, LLC
1595 Frank Road	1740-G Harmon Avenue
Columbus, Ohio 43223-0053	Columbus, Ohio 43223
crack sealing	cement stabilization



**AFFIDAVIT**

To be filed in and executed if the contractor is a corporation

STATE OF Ohio

COUNTY OF Franklin; ss:

Jonathan R. Apple  
being duly sworn, deposes and says that he/she is Secretary of

Decker Construction Company  
a corporation organized and existing under and by virtue of the laws of the state of Ohio and  
having its principal office at:

3040 McKinley Avenue Columbus, Ohio 43204  
Address/City/State/Zip

AFFIANT further says he/she is familiar with records, minutes, books, and by-laws of the said corporation and is duly authorized to sign the Contract for the construction of:

**2018 STREET PROGRAM, ST-1054**

for said corporation by virtue of: Resolution of the Board of Directors August 25, 2015  
(state whether a provision of by-laws or resolution by board. If resolution give date of adoption)

[Signature]  
Signature

Sworn to before me and subscribed in my presence this 9<sup>th</sup> day of March, 2018.

[Signature]  
Notary Public

My Commission Expires: 8-05-2020

Seal:



**LAURA ANN LOMBARDI**  
NOTARY PUBLIC, STATE OF OHIO  
MY COMMISSION EXPIRES 8-05-2020

**AFFIDAVIT  
ORC 5719.042**

STATE OF Ohio

COUNTY OF Franklin; ss:

The affiant being first duly sworn states that he or she is the

President Decker Construction Company  
Title and Name of Company

and that he/she or Decker Construction Company was  
Name of Company

Not charged at the time the bid for:

**2018 STREET PROGRAM, ST-1054**

was submitted, with any delinquent personal property taxes on the general tax list of personal property of Franklin County, Ohio; or

Charged at the time the bid for:

**2018 STREET PROGRAM, ST-1054**

was submitted, with delinquent property taxes on the general tax list of personal property of Franklin County, Ohio, and attached hereto is a statement setting forth the amount of such due and unpaid delinquent taxes and any due and unpaid penalties and interest thereon.

FURTHER AFFIANT sayeth naught:

COMPANY

Decker Construction Company

AFFIANT AND TITLE

Carl M. Schuchert, President

Sworn to before me and subscribed in my presence this 9<sup>th</sup> day of March, 2018.

Laura Ann Lombardi  
Notary Public

My Commission Expires: 8-05-2020



**LAURA ANN LOMBARDI**  
NOTARY PUBLIC, STATE OF OHIO  
MY COMMISSION EXPIRES 8-05-2020

**NONCOLLUSION AFFIDAVIT**

STATE OF Ohio

COUNTY OF Franklin; ss:

Bid Identification:

**2018 STREET PROGRAM, ST-1054**

CONTRACTOR Carl W. Scheiderer, being first duly sworn, deposes and says that he is President sole owner, a partner, president, secretary, etc.) of Decker Construction Company the party making the foregoing BID; that such bid is not made in the interest of or on behalf of any undisclosed person, partnership, company, association, organization, or corporation; that such BID is genuine and not collusive or sham; that said BIDDER has not directly or indirectly induced or solicited any other BIDDER to put in a false or sham BID, and has not directly or indirectly colluded conspired, connived, or agreed with any BIDDER or anyone else to put in a sham BID, or that anyone shall refrain from bidding; that said BIDDER has not in any manner, directly or indirectly, sought by agreement, communication or conference with anyone to fix any overhead, profit, or cost element of such BID price, or of that of any other BIDDER, or to secure any advantage against the OWNER awarding the contract or anyone interested in the proposed contract; that all statements contained in such BID are true; and further, that said BIDDER has not, directly or indirectly, submitted his BID price or any breakdown thereof, or the contents thereof, or divulged information or data relative thereto, or paid and will not pay any fee in connection therewith, to any corporation, partnership, company, association, organization, BID depository, or to any member or agent thereof, of to any other individual except to such person or persons as have a partnership or other financial interest with said BIDDER in his general business.

Signed:

Carl W. Scheiderer, President  
Signature

Sworn to before me and subscribed in my presence this 9<sup>th</sup> day of March, 2018.

Laura Ann Lombardi  
Notary Public

My Commission Expires: 8-05-2020

Seal:



**LAURA ANN LOMBARDI**  
NOTARY PUBLIC, STATE OF OHIO  
MY COMMISSION EXPIRES 8-05-2020

**ESCROW WAIVER**

**2018 STREET PROGRAM, ST-1054**

In accordance with a certain Contract between the City of Gahanna Ohio, and contractor Decker Construction Company, it is mutually agreed by and between the parties hereto that because of the short-term duration of the within contract, no escrow account will be established as is required pursuant to Sections 153.13, 153.14 and 153.63 of the Ohio Revised Code nor shall any interest be paid on retainage.

Signed:

Carl W. Schul President  
Signature

Sworn to before me and subscribed in my presence this 9<sup>th</sup> day of March, 2018.

Laura Ann Lombardi  
Notary Public

My Commission Expires: 8-05-2020

Seal:



LAURA ANN LOMBARDI  
NOTARY PUBLIC STATE OF OHIO  
MY COMMISSION EXPIRES 8-05-2020

**BID GUARANTY AND CONTRACT BOND  
(ORC Section 153.57(1))**

**KNOW ALL MEN BY THESE PRESENTS**, that we, the undersigned

Decker Construction Company, 3040 McKinley Ave., Columbus, OH 43204  
(Name and Address of Contractor)

as Principal, and Cincinnati Insurance Company,  
as Surety, are hereby held and firmly bound unto the City of Gahanna, Ohio, hereinafter called  
the Obligee, in the penal sum of the dollar amount of the bid to undertake the project known as:

**2018 STREET PROGRAM, ST-1054**

The penal sum referred to herein shall be the dollar amount of the Principal's bid to the Obligee,  
incorporating any additive or deductive alternate proposals made by the Principal on the date  
referred to above to the Obligee, which are accepted by the Obligee. In no case shall the penal  
sum exceed the amount of \_\_\_\_\_ dollars  
(\$ \_\_\_\_\_).

If the above line is left blank, the penal sum will be the full amount of the Principal's bid,  
including alternates. Alternatively, if completed, the amount stated must not be less than the full  
amount of the bid, including alternates, in dollars and cents. A percentage amount is not  
acceptable. For the payment of the penal sum well and truly to be made, we hereby jointly and  
severally bind ourselves, our heirs, executors, administrators, successors, and assigns.

THE CONDITION OF THE ABOVE OBLIGATION IS SUCH, that whereas the above named  
Principal has submitted a bid on the above referred to project:

NOW, THEREFORE, if the Obligee accepts the bid of the Principal and the Principal fails to  
enter into a proper contract in accordance with the bid, plans, details, specifications, and bills of  
material; and in the event the Principal pays to the Obligee the difference not to exceed ten  
percent of the penalty hereof between the amount specified in the bid and such larger amount for  
which the Obligee may in good faith contract with the next lowest bidder to perform the work  
covered by the bid; or in the event the Obligee does not award the contract to the next lowest  
bidder and resubmits the project for bidding, the Principal will pay the Obligee the difference not  
to exceed ten percent of the penalty hereof between the amount specified in the bid, or the costs,  
in connection with the resubmission, of printing and mailing notices to prospective bidders,  
whichever is less, than this obligation shall be void, otherwise to remain in full force and effect.  
If the Obligee accepts the bid of the principal and the Principal within ten days after the  
awarding of the contract enters into a proper contract in accordance with the bid, plans, details,  
specifications, and bills of materials, which said contract is made a part of this bond the same as  
though set forth herein; and

THE CINCINNATI INSURANCE COMPANY

Fairfield, Ohio

POWER OF ATTORNEY

KNOW ALL MEN BY THESE PRESENTS: That THE CINCINNATI INSURANCE COMPANY, a corporation organized under the laws of the State of Ohio, and having its principal office in the City of Fairfield, Ohio, does hereby constitute and appoint

Joseph W. Ray, III; Joseph W. Ray, IV; David A. Ray; Joan Marriott; Matthew P. Rappolt; Paula L. Lambert; Charles D. Craycraft, Jr.; Elizabeth L. Thomin and/or Rachel S. Jones

of Columbus, Ohio its true and lawful Attorney(s)-in-Fact to sign, execute, seal and deliver on its behalf as Surety, and as its act and deed, any and all bonds, policies, undertakings, or other like instruments, as follows:

Any such obligations in the United States, up to Ten Million and No/100 Dollars (\$10,000,000.00).

This appointment is made under and by authority of the following resolution passed by the Board of Directors of said Company at a meeting held in the principal office of the Company, a quorum being present and voting, on the 6th day of December, 1958, which resolution is still in effect:

"RESOLVED, that the President or any Vice President be hereby authorized, and empowered to appoint Attorneys-in-Fact of the Company to execute any and all bonds, policies, undertakings, or other like instruments on behalf of the Corporation, and may authorize any officer or any such Attorney-in-Fact to affix the corporate seal; and may with or without cause modify or revoke any such appointment or authority. Any such writings so executed by such Attorneys-in-Fact shall be binding upon the Company as if they had been duly executed and acknowledged by the regularly elected officers of the Company."

This Power of Attorney is signed and sealed by facsimile under and by the authority of the following Resolution adopted by the Board of Directors of the Company at a meeting duly called and held on the 7th day of December, 1973.

"RESOLVED, that the signature of the President or a Vice President and the seal of the Company may be affixed by facsimile on any power of attorney granted, and the signature of the Secretary or Assistant Secretary and the seal of the Company may be affixed by facsimile to any certificate of any such power and any such power of certificate bearing such facsimile signature and seal shall be valid and binding on the Company. Any such power so executed and sealed and certified by certificate so executed and sealed shall, with respect to any bond or undertaking to which it is attached, continue to be valid and binding on the Company."

IN WITNESS WHEREOF, THE CINCINNATI INSURANCE COMPANY has caused these presents to be sealed with its corporate seal, duly attested by its Vice President this 1st day of October, 2015.



THE CINCINNATI INSURANCE COMPANY

Signature of Stephen A. Janta

Vice President

STATE OF OHIO ) ss:
COUNTY OF BUTLER )

On this 1st day of October, 2015, before me came the above-named Vice President of THE CINCINNATI INSURANCE COMPANY, to me personally known to be the officer described herein, and acknowledged that the seal affixed to the preceding instrument is the corporate seal of said Company and the corporate seal and the signature of the officer were duly affixed and subscribed to said instrument by the authority and direction of said corporation.

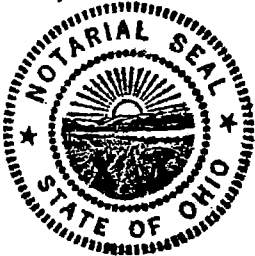

Signature of Mark J. Huller

MARK J. HULLER, Attorney at Law
NOTARY PUBLIC - STATE OF OHIO
My commission has no expiration date. Section 147.03 O.R.C.

I, the undersigned Secretary or Assistant Secretary of THE CINCINNATI INSURANCE COMPANY, hereby certify that the above is a true and correct copy of the Original Power of Attorney issued by said Company, and do hereby further certify that the said Power of Attorney is still in full force and effect.

GIVEN under my hand and seal of said Company at Fairfield, Ohio. this 9th day of March, 2018



Signature of Scott R. Bolan

Secretary



The Cincinnati Insurance Company ■ The Cincinnati Indemnity Company  
The Cincinnati Casualty Company ■ The Cincinnati Specialty Underwriters Insurance Company  
The Cincinnati Life Insurance Company

THE CINCINNATI INSURANCE COMPANY  
FINANCIAL STATEMENT  
DECEMBER 31, 2017

ASSETS

Cash	\$ 339,349,633
Bonds	5,974,885,992
Stocks	4,777,208,592
Agents Balance Receivable	1,577,830,776
All Other Admitted Assets	<u>245,604,412</u>
TOTAL ADMITTED ASSETS	<u>\$12,914,879,406</u>

LIABILITIES

Reserve for Losses and Loss Expense	\$4,776,992,531
Reserve for Unearned Premiums	2,279,405,281
All Other Liabilities	764,915,765
Capital	\$ 3,586,355
Surplus	5,089,979,474
	<u>5,093,565,829</u>
TOTAL LIABILITIES & EQUITY	<u>\$12,914,879,406</u>

State of Ohio  
County of Butler

Theresa A. Hoffer, Treasurer of The Cincinnati Insurance Company, being duly sworn for herself, deposes and says that she is the above described officer of the said company and that the above Financial Statement as of December 31, 2017 is true and correct to the best of her knowledge and belief.

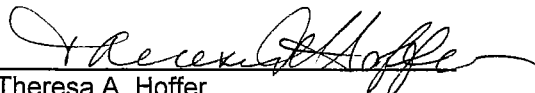
  
Theresa A. Hoffer  
Senior Vice President, Treasurer

Subscribed and sworn before me this 12<sup>th</sup> day of February,

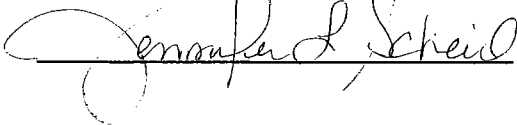



**Jennifer L. Scheid**  
Notary Public, State of Ohio  
My Commission Expires 01-16-2021

Office of Risk Assessment  
50 West Town Street  
Third Floor - Suite 300  
Columbus, Ohio 43215  
(614)644-2658  
Fax(614)644-3256  
www.insurance.ohio.gov

## Ohio Department of Insurance

John R. Kasich - Governor

Jillian Froment - Director

### Certificate of Compliance



Issued 06/27/2017

Effective 07/01/2017

Expires 06/30/2018

I, Jillian Froment, hereby certify that I am the Director of Insurance in the State of Ohio and have supervision of insurance business in said State and as such I hereby certify that

#### CINCINNATI INSURANCE COMPANY, THE

of Ohio is duly organized under the laws of this State and is authorized to transact the business of insurance under the following section(s) of the Ohio Revised Code:

##### Section 3929.01 (A)

Accident & Health	Multiple Peril - Farmowners
Aircraft	Multiple Peril - Homeowners
Allied Lines	Other Liability
Boiler & Machinery	Private Passenger Auto - Liability
Burglary & Theft	Private Passenger Auto - No Fault
Commercial Auto - Liability	Private Passenger Auto - Physical Damage
Commercial Auto - No Fault	Surety
Commercial Auto - Physical Damage	Workers Compensation
Credit	
Earthquake	
Fidelity	
Financial Guaranty	
Fire	
Glass	
Inland Marine	
Medical Malpractice	
Multiple Peril - Commercial	

CINCINNATI INSURANCE COMPANY, THE certified in its annual statement to this Department as of December 31, 2016 that it has admitted assets in the amount of \$12,092,696,643, liabilities in the amount of \$7,406,735,128, and surplus of at least \$4,685,961,515.

IN WITNESS WHEREOF, I have hereunto subscribed my name and caused my seal to be affixed at Columbus, Ohio, this day and date.

Handwritten signature of Jillian Froment in cursive.

Jillian Froment, Director





IF THE SAID Principal shall well and faithfully perform each and every condition of such contract; and indemnify the Oblige against all damage suffered by failure to perform such contract according to the provisions thereof and in accordance with the plans, details, specifications, and bills of material therefore; and shall pay all lawful claims of subcontractors, materialmen, and laborers for labor performed and materials furnished in the carrying forward, performing, or completing of said contract; we agreeing and assenting that this undertaking shall be for the benefit of any materialman or laborer having a just claim, as well as for the Oblige herein; then this obligation shall be void; otherwise the same shall remain in full force and effect; It being expressly understood and agreed that the liability of the Surety for any and all claims hereunder shall in no event exceed the penal amount of this obligation as herein stated.

THE SAID Surety hereby stipulates and agrees that no modifications, omissions, or additions, in or to the terms of said contract or in or to the plans and specifications therefore shall in any wise affect the obligations of said Surety on this bond, and it does hereby waive notice of any such modifications, omissions, or additions to the terms of the contract or to the work or to the specifications.

SIGNED AND SEALED this 9th day of March, 2018.

PRINCIPAL: Decker Construction Company

BY: Carl W. Sells

TITLE: President

BY: Paul W. Zambert  
Attorney-in-fact

SURETY COMPANY ADDRESS:

Cincinnati Insurance Company  
Company Name

PO Box 145496  
Street

Cincinnati, OH 45250  
City/State/Zip

SURETY AGENT'S ADDRESS

Ray Insurance Agency  
Agency Name

1580 Fishinger Rd.  
Street

Columbus, OH 43221  
City/State/Zip

(ORC Section 9.32 requires awarding authority give written notice of award to Surety and Agent.)

CITY OF GAHANNA

## **PROPOSAL**

### **2018 STREET PROGRAM, ST-1054**

TO: Director of Public Service  
City of Gahanna, Ohio

After careful examination of the specifications, form of contract and the site of the proposed work, the undersigned hereby proposes and agrees if this proposal be accepted, to enter into a contract using the form of contract provided for, to furnish all equipment, labor, materials and construction to complete the said work in accordance with the terms and conditions specified and to furnish a satisfactory bond in the amount of one hundred percent (100%) of the total amount of the contract, conditioned as and in form prescribed by law as a guarantee for the faithful performance of the contract for the following prices as described and contained herein.

The bidder shall fill in all unit prices shown in the proposal and make necessary extensions and add all totals. The unit prices shown, together with quantities shown shall determine the total amount of the bid. If there is an error made, unit prices shown shall govern. The City reserves the right to waive any irregularities of the bidding process, and to make any mathematical corrections as required.

NOTE: NO BIDDER MAY WITHDRAW UNTIL SIXTY DAYS AFTER THE DATE OPENING. THE CITY OF GAHANNA HAS THE OPTION OF ACCEPTING OR REJECTING ANY OR ALL PROPOSALS OR ANY PORTION THEREOF.

If the foregoing proposal shall be accepted by the City of Gahanna, State of Ohio, and the undersigned shall fail within a period of ten (10) days from the notice of acceptance to execute a satisfactory contract or furnish a satisfactory bond as stated in the notice to bidders hereto attached, then the City may, at its option, determine that the undersigned had abandoned the contract and thereupon this proposal shall be null and void and the bond or certified check accompanying this proposal shall be forfeited to and become the property of the City, otherwise the bond or certified check accompanying this proposal shall be returned to the undersigned on demand. (The appropriate blanks pertaining to the certified check or proposal bond shall be properly filled in by the bidder)

Attached hereto is a certified check on \_\_\_\_\_ Bank of Ohio, for the sum of \$ \_\_\_\_\_ according to the terms of the notice to bidders.

Attached hereto is the bid guaranty/contract bond executed by Cincinnati Insurance Company for the sum of \$ 3,469,561.07 according to the terms of the notice to bidders.

The names and residences of all persons and parties interested in the foregoing bid as principals are:

Carl W. Scheiderer, President  
Name

5953 Morganwood Square Hilliard, Ohio 43026  
Address

Jonathan R. Apple, Secretary  
Name

6984 Kindler Drive New Albany, Ohio 43054  
Address

\_\_\_\_\_  
Name

\_\_\_\_\_  
Address

\*\*\*\*\*

Decker Construction Company  
Carl W. Scheiderer President  
Signature of Bidder

3040 McKinley Avenue Columbus, Ohio  
Business Address  
43204

Signed this 9<sup>th</sup> day of March, 2018.

2018 STREET PROGRAM - ST 1054

Street Name

Shull Rd Bike Path

Curb Ramp and Bike Path

From

Morse Rd

S. Creekway Ct

Spec Item	Description	Unit	QTY Total	Quantity
203	Excavation (Bike Path)	SY	645.33	645.33
448	1-1/2" Asphalt Concrete, Surface Course	CY	75.00	75.00
608	Curb Ramp, Type C (ADA Compliant Reconfiguration)	EA	4.00	4.00
SPEC	4" of 304 Base (Bike Path)	CY	75.00	75.00

# Bid Tab

Name of Project: 2018 STREET PROGRAM - ST 1054

Crack Sealing

Street Name

From

To

Spec Item	Description	Unit	QTY Total	Quantity	Street Name	From	To
413	Crack Seal	SY	110,249.00	4,391.00	Landover Pl	Rocky Fork Blvd	Rocky Fork Blvd
				1,011.00	Wigan Ct	Rocky Fork Blvd	End of Ct
				1,869.00	Schlyer Wy	Beaverbrook Dr	Schlyer Ct
				3,105.00	Fawndale Pl	Landover Rd	Landover Rd

# Bid Tab

Name of Project: 2018 STREET PROGRAM - ST 1054

Crack Sealing

Spec Item	Description	Unit	Quantity
413	Crack Seal	SY	465.00

Street Name	Kindergarten
From	Helmbright
To	End of Ct
Quantity	465.00

Street Name	Schillingwood Dr
From	Caswell Dr
To	Helmbright Dr
Quantity	1,903.00

Street Name	Cross Pointe Dr
From	Taylor Station Rd
To	Taylor Rd
Quantity	10,485.00

Street Name	Broken Arrow Rd
From	Cliffview Dr
To	Rocky Fork Dr S
Quantity	3,946.00

Street Name	Walkcreek Dr W
From	Cherrybottom Rd
To	Parkedge Dr
Quantity	3,406.00

# Bid Tab

Name of Project: 2018 STREET PROGRAM - ST 1054

Crack Sealing

Spec Item	Description	Unit	Quantity
413	Crack Seal	SY	3,195.00

Street Name	From	To
Parkedge Dr	Walkcreek Dr W	Laurel Ridge Dr

Marrus	Walcreek Dr W	Parkedge Dr	Quantity	3,796.00
--------	---------------	-------------	----------	----------

Sumption Dr	Ridenour Rd	Ridenour Rd	Quantity	5,399.00
-------------	-------------	-------------	----------	----------

Ridenour Rd (North End)	Stygler Rd	Carlin Ct W	Quantity	12,376.00
-------------------------	------------	-------------	----------	-----------

Hartney Dr	Ridenour Rd	Ridenour Rd	Quantity	3,256.00
------------	-------------	-------------	----------	----------

# Bid Tab

Name of Project: 2018 STREET PROGRAM - ST 1054

Crack Sealing

Spec Item	Description	Unit	Quantity
413	Crack Seal	SY	4,004.00

Street Name	McDonnell Dr
From	Ridenour Rd
To	Ainsworth Ave

Hedley Pl	Ainsworth Ave	End of Ct	Quantity	1,378.00
-----------	---------------	-----------	----------	----------

Carlin Ct E	Ridenour Rd	Olde Ridenour Rd	Quantity	904.00
-------------	-------------	------------------	----------	--------

Price Rd	James Rd	End of Ct.	Quantity	1,989.00
----------	----------	------------	----------	----------

Denison	Goshen Ln	Citadel St	Quantity	4,533.00
---------	-----------	------------	----------	----------



# Bid Tab

Name of Project: 2018 STREET PROGRAM - ST 1054

Crack Sealing		Street Name	Prince of Wales Dr
From	Regenis Rd	To	Imperial Dr
Spec Item	Description	Unit	Quantity
413	Crack Seal	SY	3,675.00

Lincolnshire Rd	Palace Ln	Agler Rd	Quantity	2,632.00
-----------------	-----------	----------	----------	----------

Regal Pl	Dunchurch Rd	End of Ct	Quantity	670.00
----------	--------------	-----------	----------	--------

Lindenhaven Rd	Lindenhaven Ct	Forestwood Dr	Quantity	2,133.00
----------------	----------------	---------------	----------	----------

Forestwood Dr	Stygler Rd	Humboldt Dr	Quantity	6,877.00
---------------	------------	-------------	----------	----------

# Bid Tab

Name of Project: 2018 STREET PROGRAM - ST 1054

Crack Sealing

Spec Item	Description	Unit	Quantity
413	Crack Seal	SY	526.00

Academy Ct E	Academy Ct	End of Ct	Quantity	607.00
-----------------	------------	-----------	----------	--------

Academy Ct W	Academy Ct	End of Ct	Quantity	575.00
-----------------	------------	-----------	----------	--------

Tresham Rd	Hamilton Rd E Wickham Way	End of Ct	Quantity	4,550.00
------------	---------------------------------	-----------	----------	----------

Langford Ct	Hamilton Rd	End of Ct	Quantity	2,066.00
-------------	-------------	-----------	----------	----------

# Bid Tab

Name of Project: 2018 STREET PROGRAM - ST 1054

Crack Sealing

Spec Item	Description	Unit	Quantity
413	Crack Seal	SY	638.00

Street Name	From	To	Quantity
Tresham Ct	Tresham Rd	End of Ct	638.00

Street Name	From	To	Quantity
Venetian Way	Deer Run Dr	Roebuck Dr	3,060.00

Street Name	From	To	Quantity
Venetian Way	Riva Ridge Dr	Tim Tam Ave	2,932.00

Street Name	From	To	Quantity
Shull Rd	County Corp	County Corp	2,686.00

Street Name	From	To	Quantity
Heritage St	Clark St Rd	Hannah Farms Ct	4,258.00

# Bid Tab

Name of Project: 2018 STREET PROGRAM - ST 1054

Crack Sealing

Spec Item	Description	Unit	Quantity
413	Crack Seal	SY	953.00

Street Name	Suzanne Way
From	Hannah Farms Ct
To	End of Ct.

# Detroit Street Rebuild Opinion of Cost

Name of Project: 2018 STREET PROGRAM - ST 1054

Street Name

Canterwood Ct

Detroit Rebuilds

From

To

Denwood Dr N. (+Int)

End of Ct

Spec Item	Description	Unit	2018 QTY's	Quantity	Quantity
203	Excavation	LS	8.00	1.00	0.50
SPEC	Cement Stabilization	SY	18180.00	2,773.00	947.00
SPEC	7" Roller Compacted Concrete Base	SY	18180.00	2,773.00	947.00
407	Tack Coat (Trackless)	GAL	1818.00	277.00	95.00
410	Traffic Compacted Surface	CY	550.00	50.00	50.00
418	Sawing & Sealing Asphalt Concrete Pavement Joint	LS	8.00	1.00	0.50
448	1-1/2" Asphalt Concrete, Intermediate Course	CY	765.00	120.00	40.00
448	1-1/2" Asphalt Concrete, Surface Course	CY	765.00	120.00	40.00
608	5' Concrete Walk	SF	11430.00		
608	Curb Ramp, Type C (ADA Compliant Reconfiguration)	EA	26.00	2.00	4.00
609	Combination Curb & Gutter Inc. 4" Underdrain	LF	12457.00	1,762.00	740.00
614	Maintenance of Traffic	LS	9.00	1.00	1.00
623	Construction Layout Stakes	LS	9.00	1.00	1.00
644	Crosswalk	LF	1071.00	50.00	184.00
644	Stop Line	LF	240.00	12.00	48.00
653 & 659	Topsoil, Seeding & Mulching	LS	9.00	1.00	1.00
SPEC	Asphalt Expansion Joints	EA	17.00	1.00	1.00
SPEC	Remove/Replace Base of Concrete Drives	SY	1364.00	298.00	65.00
SPEC	Remove/Reset Curb Inlet	EA	29.00	5.00	2.00

Gary Lee Dr

Flint Ridge Dr

Hamilton Rd

Quantity

1.25

4,350.00

4,350.00

435.00

100.00

1.25

182.00

182.00

11,430.00

8.00

2,806.00

1.25

1.25

204.00

36.00

1.25

4.00

279.00

9.00

Walnut St

Shull Ave

Shepard St

Quantity

0.50

947.00

947.00

95.00

50.00

0.50

40.00

40.00

4.00

740.00

1.00

1.00

184.00

48.00

1.00

1.00

65.00

2.00

# Detroit Street Rebuild Opinion of Cost

Name of Project: 2018 STREET PROGRAM - ST 1054

Street Name: Gamewood Dr

Detroit Rebuilds

From Stygler Rd  
To Foxwood Dr

Spec Item	Description	Unit	Quantity	Shepard St	Foxwood/Denwood St
203	Excavation	LS	0.25		
SPEC	Cement Stabilization	SY	797.00	Carpenter Rd	Gamewood Dr
SPEC	7" Roller Compacted Concrete Base	SY	797.00	Walnut St	Dovewood Dr (+Int)
407	Tack Coat (Trackless)	GAL	80.00	Quantity	Quantity
410	Traffic Compacted Surface	CY	50.00	0.70	1.00
418	Sawing & Sealing Asphalt Concrete Pavement Joint	LS	0.25	1,348.00	2,360.00
448	1-1/2" Asphalt Concrete, Intermediate Course	CY	34.00	1,348.00	2,360.00
448	1-1/2" Asphalt Concrete, Surface Course	CY	34.00	135.00	236.00
608	5' Concrete Walk	SF		50.00	50.00
608	Curb Ramp, Type C (ADA Compliant Reconfiguration)	EA		0.70	1.00
609	Combination Curb & Gutter Inc. 4" Underdrain	LF	522.00	56.00	98.00
614	Maintenance of Traffic	LS	0.50	56.00	98.00
623	Construction Layout Stakes	LS	0.50		
644	Crosswalk	LF	50.00	4.00	
644	Stop Line	LF	12.00	1,041.00	1,651.00
653 & 659	Topsoil, Seeding & Mulching	LS	0.40	1.00	1.00
SPEC	Asphalt Expansion Joints	EA	1.00	1.00	2.00
SPEC	Remove/Replace Base of Concrete Drives	SY	57.00	184.00	233.00
SPEC	Remove/Reset Curb Inlet	EA		48.00	2.00

# Detroit Street Rebuild Opinion of Cost

Name of Project: 2018 STREET PROGRAM - ST 1054

Street Name: Brookhaven Dr. E (Eastern Section)

Detroit Rebuilds

Spec Item	Description	Unit	From		Quantity	Baroness Way		Quantity	Kenilworth Ct	
			Dumbarton Rd	Landstown Rd		Imperial	Coronation Dr		Amesbury Dr	Lincolnshire Rd
203	Excavation	LS			0.46			1.20		1.25
SPEC	Cement Stabilization	SY			968.88			2,209.00		2,427.00
SPEC	7" Roller Compacted Concrete Base	SY			968.88			2,209.00		2,427.00
407	Tack Coat (Trackless)	GAL			97.00			220.00		243.00
410	Traffic Compacted Surface	CY			50.00			50.00		100.00
418	Sawing & Sealing Asphalt Concrete Pavement Joint	LS			0.50			1.00		1.25
448	1-1/2" Asphalt Concrete, Intermediate Course	CY			40.40			93.00		101.00
448	1-1/2" Asphalt Concrete, Surface Course	CY			40.40			93.00		101.00
608	5' Concrete Walk	SF								
608	Curb Ramp, Type C (ADA Compliant Reconfiguration)	EA			2.00			2.00		4.00
609	Combination Curb & Gutter Inc. 4" Underdrain	LF			654.81			1,581.00		1,699.00
614	Maintenance of Traffic	LS			1.00			1.00		1.25
623	Construction Layout Stakes	LS			1.00			1.00		1.25
644	Crosswalk	LF			55.00			120.00		172.00
644	Stop Line	LF			12.00			24.00		36.00
653 & 659	Topsoil, Seeding & Mulching	LS			0.46			1.00		1.25
SPEC	Asphalt Expansion Joints	EA			1.00			1.00		3.00
SPEC	Remove/Replace Base of Concrete Drives	SY			54.29			200.00		177.10
SPEC	Remove/Reset Curb Inlet	EA						4.00		4.00

# Detroit Street Rebuild Opinion of Cost

Name of Project: 2018 STREET PROGRAM - ST 1054

Street Name: Worman Dr

Detroit Rebuilds

From: Hamilton Rd  
To: End of Ct

Spec Item	Description	Unit	Quantity
203	Excavation	LS	2.00
SPEC	Cement Stabilization	SY	4,862.00
SPEC	7" Roller Compacted Concrete Base	SY	4,862.00
407	Tack Coat (Trackless)	GAL	486.00
410	Traffic Compacted Surface	CY	100.00
418	Sawing & Sealing Asphalt Concrete Pavement Joint	LS	2.00
448	1-1/2" Asphalt Concrete, Intermediate Course	CY	203.00
448	1-1/2" Asphalt Concrete, Surface Course	CY	203.00
608	5' Concrete Walk	SF	
608	Curb Ramp, Type C (ADA Compliant Reconfiguration)	EA	8.00
609	Combination Curb & Gutter Inc. 4" Underdrain	LF	3,228.00
614	Maintenance of Traffic	LS	2.00
623	Construction Layout Stakes	LS	2.00
644	Crosswalk	LF	162.00
644	Stop Line	LF	24.00
653 & 659	Topsoil, Seeding & Mulching	LS	2.00
SPEC	Asphalt Expansion Joints	EA	4.00
SPEC	Remove/Replace Base of Concrete Drives	SY	518.00
SPEC	Remove/Reset Curb Inlet	EA	5.00



# Bid Tab

Name of Project: 2018 STREET PROGRAM - ST 1054

Street Name

Resurfacing Projects

Spec Item	Description	Unit	2018 QTY'S	From To		Quantity
				From	To	
254	1" to 3" Planing	SY	51,863.73	Vivian Ct ✓	Greenbank ✓	
407	Tack Coat (Trackless)	GAL	5,190.00	Laurel Ridge	Audra Ct ✓	2,225.00
448	1-1/2" Asphalt Concrete, Intermediate Course	CY	2,196.00	End of Ct	Parkedge	223.00
448	1-1/2" Asphalt Concrete, Surface Course	CY	2,026.00	End of Ct	End of Ct	93.00
448	1-1/2" Asphalt Concrete, Surface Course 70-22M	CY	170.00	Laurel Ridge	Brookhill Dr	93.00
608	4' Concrete Walk	SF	125.00	End of Ct	Quantity	
608	Curb Ramp, Type C (ADA Compliant Reconfiguration)	EA	40.00	Quantity	Quantity	
609	Curb Replacement	LF	5,750.00	763.00	1626.00	2.00
644	Crosswalk	LF	1,346.00	76.00	163.00	195.00
644	Stop Line	LF	378.00	32.00	68.00	100.00
608	Curb Ramp, Type C (Truncated Dome Replacement)	EA	2.00	32.00	68.00	24.00

# Bid Tab

Name of Project: 2018 STREET PROGRAM - ST 1054

Resurfacing Projects

Spec Item	Description	Unit	Quantity	Street Name		S. Creekway Ct	Riva Pl	Ridge Pl	Crossing Creek S.
				From	To				
254	1" to 3" Planing	SY	815.00	Midhurst Dr	Greenbank				✓
407	Tack Coat (Trackless)	GAL	82.00	Haybrook Dr					
448	1-1/2" Asphalt Concrete, Intermediate Course	CY	34.00						McKenna Creek Dr.
448	1-1/2" Asphalt Concrete, Surface Course	CY	34.00						US-62
448	1-1/2" Asphalt Concrete, Surface Course 70-22M	CY							Quantity
608	4' Concrete Walk	SF							4,943.95
608	Curb Ramp, Type C (ADA Compliant Reconfiguration)	EA	2.00						494.00
609	Curb Replacement	LF	90.00						206.00
644	Crosswalk	LF	50.00					80.00	
644	Stop Line	LF	12.00						162.00
608	Curb Ramp, Type C (Truncated Dome Replacement)	EA							24.00

# Bid Tab

Name of Project: 2018 STREET PROGRAM - ST 1054

Resurfacing Projects

Spec Item	Description	Unit	Quantity	Street Name	
				From	To
254	1" to 3" Planning	SY	3,430.00	Dark Star Rd	Zodiac Ave
407	Tack Coat (Trackless)	GAL	343.00	Aries Dr	
448	1-1/2" Asphalt Concrete, Intermediate Course	CY	143.00		
448	1-1/2" Asphalt Concrete, Surface Course	CY	143.00		
448	1-1/2" Asphalt Concrete, Surface Course 70-22M	CY			
608	4' Concrete Walk	SF			
608	Curb Ramp, Type C (ADA Compliant Reconfiguration)	EA	2.00		
609	Curb Replacement	LF	270.00		
644	Crosswalk	LF	24.00		
644	Stop Line	LF	72.00		
608	Curb Ramp, Type C (Truncated Dome Replacement)	EA			

Higley Ct		Quantity
Howland Dr		782.00
End of Ct		78.00
		35.00
		35.00

Cloverly Dr		Quantity
Winfall Dr		3,014.00
Caroway Blvd		301.00
		126.00
		126.00
		6.00
		175.00
		144.00
		24.00

Black Gold Pl		Quantity
Black Gold		1,441.00
End of Ct.		144.00
		63.00
		63.00
		100.00

Taurus		Quantity
Moon Glow Ct		1,340.00
Dark Star		134.00
		56.00
		56.00
		50.00
		24.00
		12.00

# Bid Tab

Name of Project: 2018 STREET PROGRAM - ST 1054

Resurfacing Projects

Spec Item	Description	Unit	Street Name		Quantity
			From	To	
254	1" to 3" Planing	SY	Waterbury	Schyler Way	3,108.00
407	Tack Coat (Trackless)	GAL			311.00
448	1-1/2" Asphalt Concrete, Intermediate Course	CY			130.00
448	1-1/2" Asphalt Concrete, Surface Course	CY			130.00
448	1-1/2" Asphalt Concrete, Surface Course 70-22M	CY			
608	4' Concrete Walk	SF			
608	Curb Ramp, Type C (ADA Compliant Reconfiguration)	EA			4.00
609	Curb Replacement	LF			600.00
644	Crosswalk	LF			160.00
644	Stop Line	LF			24.00
608	Curb Ramp, Type C (Truncated Dome Replacement)	EA			

Landrum Ct		Quantity
Claycraft Rd		1,327.00
End of Ct		133.00
		55.00
		55.00
		350.00
		16.00

Armor Hill Dr		Quantity
Highbury Crescent		1,332.00
End of Ct		133.00
		56.00
		56.00
		200.00
		52.00
		12.00

Emory St		Quantity
Skinner		1,983.00
Oakshade + Intersection		198.00
		83.00
		83.00
		4.00
		35.00
		100.00
		24.00

Emory St		Quantity
Oakshade		1,091.00
Howland		110.00
		45.00
		45.00
		25.00

# Bid Tab

Name of Project: 2018 STREET PROGRAM - ST 1054

Resurfacing Projects

Spec Item	Description	Unit	Quantity	Street Name	
				From	To
254	1" to 3" Planing	SY	1,579.00	Muskingum Ct	Kames Way ✓
407	Tack Coat (Trackless)	GAL	157.00	Bowling Green	
448	1-1/2" Asphalt Concrete, Intermediate Course	CY	66.00		
448	1-1/2" Asphalt Concrete, Surface Course	CY	66.00		
448	1-1/2" Asphalt Concrete, Surface Course 70-22M	CY			
608	4' Concrete Walk	SF			
608	Curb Ramp, Type C (ADA Compliant Reconfiguration)	EA	2.00		
609	Curb Replacement	LF	800.00		
644	Crosswalk	LF	80.00		
644	Stop Line	LF	12.00		
608	Curb Ramp, Type C (Truncated Dome Replacement)	EA			

Whispering Meadow Ct ✓		Quantity
Harrison Pond Dr		1,411.00
End of Ct		141.00
		59.00
		59.00
		2.00
		225.00
		50.00
		12.00

Harrison Pond Dr ✓		Quantity
Morse Rd		2,550.00
Whispering Meadow Ct		255.00
		106.00
		106.00
		2.00
		550.00
		50.00
		12.00

Harrison Pond Dr ✓		Quantity
Whispering Meadow		1,359.00
Pond Hollow (+ Int)		136.00
		57.00
		57.00
		2.00
		450.00
		50.00
		12.00

Harrison Pond Dr ✓		Quantity
Pond Hollow		2,568.00
Kames Way		257.00
		107.00
		107.00
		125.00
		4.00
		650.00
		150.00
		40.00



# Bid Tab

Name of Project: 2018 STREET PROGRAM - ST 1054

Street Name

North Hamilton Rd

South Hamilton Rd

West Johnstown Rd

Stygler and Agler

## Striping

From

To

Spec Item	Description	Unit	QTY Totals	Quantity
644	Edge Line, White	MI	2.23	
644	Edge Line, Yellow	MI	1.21	
644	Lane Line	MI	3.16	1.19
644	Center Line	MI	1.98	0.43
644	Channelizing Line	LF	6,828.00	1,383.00
644	Stop Line	LF	570.00	132.00
644	Crosswalk Line	LF	1,704.00	282.00
644	Transverse Line (Within Crosswalks)	LF	700.00	
644	Transverse Line, Yellow	LF	420.00	300.00
644	Transverse Line, White	LF	355.00	60.00
644	School Symbol Marking, 120"	EA	4.00	1.00
644	Lane Arrow	EA	71.00	16.00
644	Lane Arrow, Combination	EA	6.00	
644	Word on Pavement, 96"	EA	31.00	4.00
644	Dotted Line, 6"	LF	140.00	

Corp Limit

Olde Ridenour

Quantity

2.23

1.20

110.00

12.00

4.00

Granville St

Rocky Fork S

Quantity

1.19

0.43

1,383.00

132.00

282.00

300.00

60.00

1.00

16.00

4.00

Intersection

Quantity

0.06

1,150.00

66.00

578.00

11.00

6.00

11.00

140.00

# Bid Tab

Name of Project: 2018 STREET PROGRAM - ST 1054

Walnut/Shepard St Waterline Improvements

Spec Item	Description	Unit	QTY Totals
801	8" Waterline, PVC C900(DR18)	LF	1,100.00
801	6" Waterline, DIP	LF	60.00
809	Fire Hydrant	EA	2.00
SPEC	Connection to Existing WL	EA	4.00
802	8" Gate Valve	EA	6.00
802	6" Gate Valve	EA	4.00
816	3/4" Service Line Connection	EA	17.00
816	1" Service Line Connection	EA	3.00
448	Full Depth Pavement Repair	SY	180.00



# Bid Tab

Name of Project: 2018 STREET PROGRAM, ST-1054

Contractor: Decker Construction Company

Address: 3040 McKinley Avenue

Columbus, Ohio 43204

Bid Opening: March 9, 2018

Phone Number: (614) 488-7958

Base Bid								
Bid Item	Spec Item	Description	Unit	Qty	Labor	Material	Unit Price	Bid Price
1	203	Excavation (Bike Path)	SY	645	25.32	0.00	\$ 25.32	\$ 16331.40
2	203	Excavation	LS	1	196865.63	0.00	\$ 196865.63	\$ 196865.63
3	203	4" of 304 Base (Bike Path)	CY	75	61.06	31.00	\$ 92.06	\$ 6904.50
4	SPEC	Cement Stabilization	SY	18,180	6.98	3.00	\$ 9.98	\$ 181436.40
5	254	1" to 3" Planing	SY	51,864	1.86	0.00	\$ 1.86	\$ 96467.04
6	SPEC	7" Roller Compacted Concrete Base	SY	18,180	6.75	16.00	\$ 22.75	\$ 413595.00
7	407	Tack Coat (Trackless)	GAL	7,008	1.00	3.45	\$ 4.45	\$ 31185.60
8	410	Traffic Compacted Surface	CY	550	9.00	16.00	\$ 25.00	\$ 13750.00
9	413	Crack Seal	SY	110,249	0.16	0.20	\$ 0.36	\$ 39689.64
10	418	Sawing & Sealing Asphalt Concrete Pavement Joint	LS	1	24713.82	0.00	\$ 24713.82	\$ 24713.82
11	448	1-1/2" Asphalt Concrete, Intermediate Course	CY	2,961	34.14	103.00	\$ 137.14	\$ 406071.54
12	448	1-1/2" Asphalt Concrete, Surface Course	CY	2,866	34.74	119.00	\$ 153.74	\$ 440618.84
13	448	1-1/2" Asphalt Concrete, Surface Course 70-22M	CY	170	34.74	134.00	\$ 168.74	\$ 28685.80
14	608	5' Concrete Walk	SF	11,430	4.88	1.75	\$ 6.63	\$ 75780.90
15	608	4' Concrete Walk	SF	2,445	5.67	2.70	\$ 8.37	\$ 20464.65
16	608	Curb Ramp, Type C (ADA Compliant Reconfiguration)	EA	70	772.99	393.14	\$ 1166.13	\$ 81629.10
17	609	Combination Curb & Gutter Inc. 4" Underdrain	LF	12,457	9.28	8.47	\$ 17.75	\$ 221111.75
18	609	Curb Replacement	LF	5,750	25.08	9.08	\$ 34.16	\$ 196420.00
19	614	Maintenance of Traffic	LS	1	18000.00	12000.00	\$ 30000.00	\$ 30000.00
20	623	Construction Layout Stakes	LS	1	18000.00	2000.00	\$ 20000.00	\$ 20000.00
21	644	Crosswalk	LF	4,121	1.82	0.75	\$ 2.57	\$ 10590.97
22	644	Stop Line	LF	1,188	3.15	2.00	\$ 5.15	\$ 6118.20
23	653 & 659	Topsoil, Seeding & Mulching	LS	1	10000.00	30000.00	\$ 40000.00	\$ 40000.00
24	608	Curb Ramp, Type C (Truncated Dome Replacement)	EA	2	678.11	350.00	\$ 1028.11	\$ 2056.22
25	SPEC	Asphalt Expansion Joints	EA	17	1005.00	245.00	\$ 1250.00	\$ 21250.00
26	SPEC	Remove/Replace Base of Concrete Drives	SY	1,363	51.98	21.79	\$ 73.77	\$ 100548.51
27	SPEC	Remove/Reset Curb Inlet	EA	29	127.48	50.00	\$ 177.48	\$ 5146.92
28	644	Edge Line, White	MI	2.23	901.00	1056.00	\$ 1957.00	\$ 4364.11
29	644	Edge Line, Yellow	MI	1.21	901.00	1056.00	\$ 1957.00	\$ 2367.97
30	644	Lane Line	MI	3:16	553.50	528.00	\$ 1081.50	\$ 3417.54
31	644	Center Line	MI	1.98	1699.00	2112.00	\$ 3811.00	\$ 7545.78
32	644	Channelizing Line	LF	6,828	0.74	0.50	\$ 1.24	\$ 8466.72
33	644	Transverse Line (Within Crosswalks)	LF	700	3.89	1.00	\$ 4.89	\$ 3423.00
34	644	Transverse Line, Yellow	LF	420	3.89	1.00	\$ 4.89	\$ 2053.80

\$ 96,465.18

\$ 3,488.98

# Bid Tab

Name of Project: 2018 STREET PROGRAM, ST-1054

Contractor: Decker Construction Company  
 Address: 3040 McKinley Avenue  
Columbus, Ohio 43204  
 Phone Number: (614) 488-7958

Bid Opening: March 9, 2018

Phone Number:

35	644	Transverse Line, White	LF	355	3.89	1.00	\$ 4.89	\$ 1735.95
36	644	School Symbol Marking, 120"	EA	4	335.60	200.00	\$ 535.60	\$ 2142.40
37	644	Lane Arrow	EA	71	39.31	40.00	\$ 79.31	\$ 5631.01
38	644	Lane Arrow, Combination	EA	6	51.97	50.00	\$ 101.97	\$ 611.82
39	644	Word on Pavement, 96"	EA	31	51.97	50.00	\$ 101.97	\$ 3161.07
40	644	Dotted Line, 6"	LF	140	0.98	0.20	\$ 1.18	\$ 165.20
41	801	8" Waterline, PVC C900(DR18)	LF	1,100	83.60	40.00	\$ 123.60	\$ 135960.00
42	801	6" Waterline, DIP	LF	60	111.11	30.00	\$ 141.11	\$ 8466.60
43	809	6" Fire Hydrant	EA	2	1260.98	2000.00	\$ 3260.98	\$ 6521.96
44	809	Relocate Existing 6" Fire Hydrant	EA	1	2567.34	500.00	\$ 3067.34	\$ 3067.34
45	SPEC	Connection to Existing WL	EA	4	204.54	20.00	\$ 224.54	\$ 898.16
46	802	8" Gate Valve	EA	6	600.62	1000.00	\$ 1600.62	\$ 9603.72
47	802	6" Gate Valve	EA	4	453.51	800.00	\$ 1253.51	\$ 5014.04
48	816	3/4" Service Line Connection	EA	17	1203.62	500.00	\$ 1703.62	\$ 28961.54
49	816	1" Service Line Connection	EA	3	757.18	1000.00	\$ 1757.18	\$ 5271.54
50	448	Full Depth Pavement Repair	SY	180	94.93	25.62	\$ 120.55	\$ 21699.00

TOTAL (BASE BID):

\$ 2,997,982.70

\$ 2,997,984.28

# Bid Tab

Name of Project: 2018 STREET PROGRAM, ST-1054

Contractor: Decker Construction Company

Address: 3040 McKinley Avenue

Columbus, Ohio 43204

Bid Opening: March 9, 2018

Phone Number: (614) 488-7958

## ALTERNATE BIDS

The pricing of the alternates is mandatory. The City may select the base bid only, or a combination of the base bid with the alternate bids to determine the lowest and best bidder.

### ALTERNATE 1

**Worman Drive Street Rebuild**

Bid Item	Spec Item	Description	Unit	Qty	Labor	Material	Unit Price	Total
51	203	Excavation	LS	1	39433.68	0.00	\$ 39433.68	\$ 39433.68
52	203	Cement Stabilization	SY	4,862	6.98	3.00	\$ 9.98	\$ 48522.76
53	SPEC	7" Roller Compacted Concrete Base	SY	4,862	6.75	16.00	\$ 22.75	\$ 110610.50
54	407	Tack Coat (Trackless)	GAL	486	1.00	3.45	\$ 4.45	\$ 2162.70
55	410	Traffic Compacted Surface	CY	100	9.00	16.00	\$ 25.00	\$ 2500.00
56	418	Sawing & Sealing Asphalt Concrete Pavement Joint	LS	1	6609.51	0.00	\$ 6609.51	\$ 6609.51
57	448	1-1/2" Asphalt Concrete, Intermediate Course	CY	203	34.38	103.00	\$ 137.38	\$ 27888.14
58	448	1-1/2" Asphalt Concrete, Surface Course	CY	203	34.38	119.00	\$ 153.38	\$ 31136.14
59	608	Curb Ramp, Type C (ADA Compliant Reconfiguration)	EA	8	699.88	361.25	\$ 1061.13	\$ 8489.04
60	609	Combination Curb & Gutter Inc. 4" Underdrain	LF	3,228	10.96	8.48	\$ 19.44	\$ 62752.32
61	614	Maintenance of Traffic	LS	1	1112.00	1888.00	\$ 3000.00	\$ 3000.00
62	623	Construction Layout Stakes	LS	1	4342.00	500.00	\$ 4842.00	\$ 4842.00
63	644	Crosswalk	LF	162	1.82	0.75	\$ 2.57	\$ 416.34
64	644	Stop Line	LF	24	3.15	2.00	\$ 5.15	\$ 123.60
65	653 & 659	Topsoil, Seeding & Mulching	LS	1	3476.00	4676.00	\$ 8152.00	\$ 8152.00
66	SPEC	Asphalt Expansion Joints	EA	4	1005.00	245.00	\$ 1250.00	\$ 5000.00
67	SPEC	Remove/Replace Base of Concrete Drives	SY	518	58.58	21.80	\$ 80.38	\$ 41636.84
68	SPEC	Remove/Reset Curb Inlet	EA	5	127.48	50.00	\$ 177.48	\$ 887.40

TOTAL (Alternate 1): \$ 404162.97 OK

### ALTERNATE 2

**Reclamite Asphalt Rejuvenating Agent**

Bid Item	Spec Item	Description	Unit	Qty	Labor	Material	Unit Price	Total
69	SPEC	Reclamite Asphalt Rejuvenating Agent	SY	74,906	0.40	0.50	\$ 0.90	\$ 67415.40

TOTAL (Alternate 2): \$ 67415.40 OK

# **Appendix D**

---

## **Map and Exhibits**

# 2018 Street Program ST-1054



200 S Hamilton Rd | Gahanna, OH 43230 | 614-342-4005 | www.gahanna.gov

## REBUILD

- Cantenwood Ct (Denwood Dr N to End of Ct)
- Gary Lee Dr (Pimbridge Dr to Hamilton Rd)
- Walnut St (Shull Rd to Shepard St)
- Gamewood Dr (Styler to Foxwood)
- Shepard St (Capenter Road to Walnut)
- Foxwood/Denwood St (Gamewood to Dovewood)
- Worman Dr (Hamilton Rd to End of Ct)
- Brookhaven Dr E (Dunbarton Rd to Landsdown Rd)
- Baroness Way (Imperial to Coronation Dr)
- Kenilworth Ct (Amsbury to Lincolnshire)

## OVERLAY

- Vivian Ct (Laurel Ridge Dr to End of Ct)
- Francis Ct (Laurel Ridge Dr to End of Ct)
- Audra Ct (Parkedge to End of Ct)
- Greenbank Rd (Raybrook Dr to Brookhill Dr)
- S. Creekway St (Shull Rd to End of Ct)
- Riva Pl (Riva Ridge Dr to End of Ct)
- Ridge Pl (Riva Ridge Dr to End of Ct)
- Crossing Creek S. (McKenna Creek Dr to US-62)
- Zodiac Ave (Dark Star Rd to Aries Dr)
- Highway Ct (Howland Dr to End of Ct)
- Clovery Dr (Wintail Dr to Caroway Blvd)
- Black Gold Pl (Black Gold Ave to End of Ct)
- Taurus (Moon Glow Ct to Dark Star Dr)
- Schlyer Way (Waterbury Blvd to Schlyer Ct)
- Lendrum Ct (Claycraft Rd to End of Ct)
- Armor Hill Dr (Highbury Crescent to End of Ct)
- Emory St (Skinner Dr to Howland Dr)
- Kames Way (Stull Rd to Harrison Pond Dr)
- Whispering Meadow Ct (Harrison Pond to End of Ct)
- Harrison Pond Dr (Morse Rd to Kames Way)
- Harrow Ct (Harrow Blvd to End of Ct)
- Heger Ct (Schlyer Way to End of Ct)
- Warlock Ct (Dunoon Dr to End of Ct)
- West Johnstown Rd (Corp Limit to Marinell Ln)

## CRACK SEAL

- Landover Pl (Rocky Fork Blvd to Rocky Fork Blvd)
- Wigan Ct (Rocky Fork Blvd to End of Ct)
- Schlyer Way (Beaverbrook Dr to Schlyer Ct)
- Fairdale Pl (Landover Rd to Landover Rd)
- Kinder Pl (Helmbright to End of Ct)
- Schillingwood Dr (Caswell Dr to Helmbright Dr)
- Cross Pointe Dr (Taylor Station Rd to Taylor Rd)
- Broken Arrow Rd (Cliffview Dr to Rocky Fork Dr S)
- Walcreek Dr W (Cherrybottom Rd to Parkedge Dr)
- Parkedge Dr (Walcreek Dr W to Laurel Ridge Dr)
- Marius (Walcreek Dr W to Parkedge Dr)
- Sumption Dr (Ridenour Rd to Ridenour Rd)
- Hatfield Rd (North Sect) (Styler Rd to Carlin Ct W)
- McDonnell Dr (Ridenour Rd to Ridenour Rd)
- Hedley Pl (Ainsworth Ave to End of Ct)
- Carlin Ct E (Ridenour Rd to Old Ridenour Rd)
- Price Rd (James Rd to End of Ct)
- Denison (Goshen Ln to Ciladel St)
- Prince of Wales Dr (Regents Rd to Imperial Dr)
- Lincolnshire Rd (Palace Ln to Agler Rd)
- Regal Pl (Dunchurch Rd to End of Ct)
- Forestwood Dr (Lindenmaen Ct to Forestwood Dr)
- Academy Ct S (Academy Ct to End of Ct)
- Academy Ct E (Academy Ct to End of Ct)
- Academy Ct W (Academy Ct to End of Ct)
- Tresham Rd (Hamilton Rd to E Wickham Way)
- Lengford Ct (Hamilton Rd to End of Ct)
- Tresham Ct (Tresham Rd to End of Ct)
- Venetian Way (Deer Run Dr to Roebuck Dr)
- Venetian Way (Riva Ridge Dr to Tim Tam Ave)
- Shull Rd (County Corp to County Corp)
- Heritage St (Clark St Rd to Hannah Farms Ct)

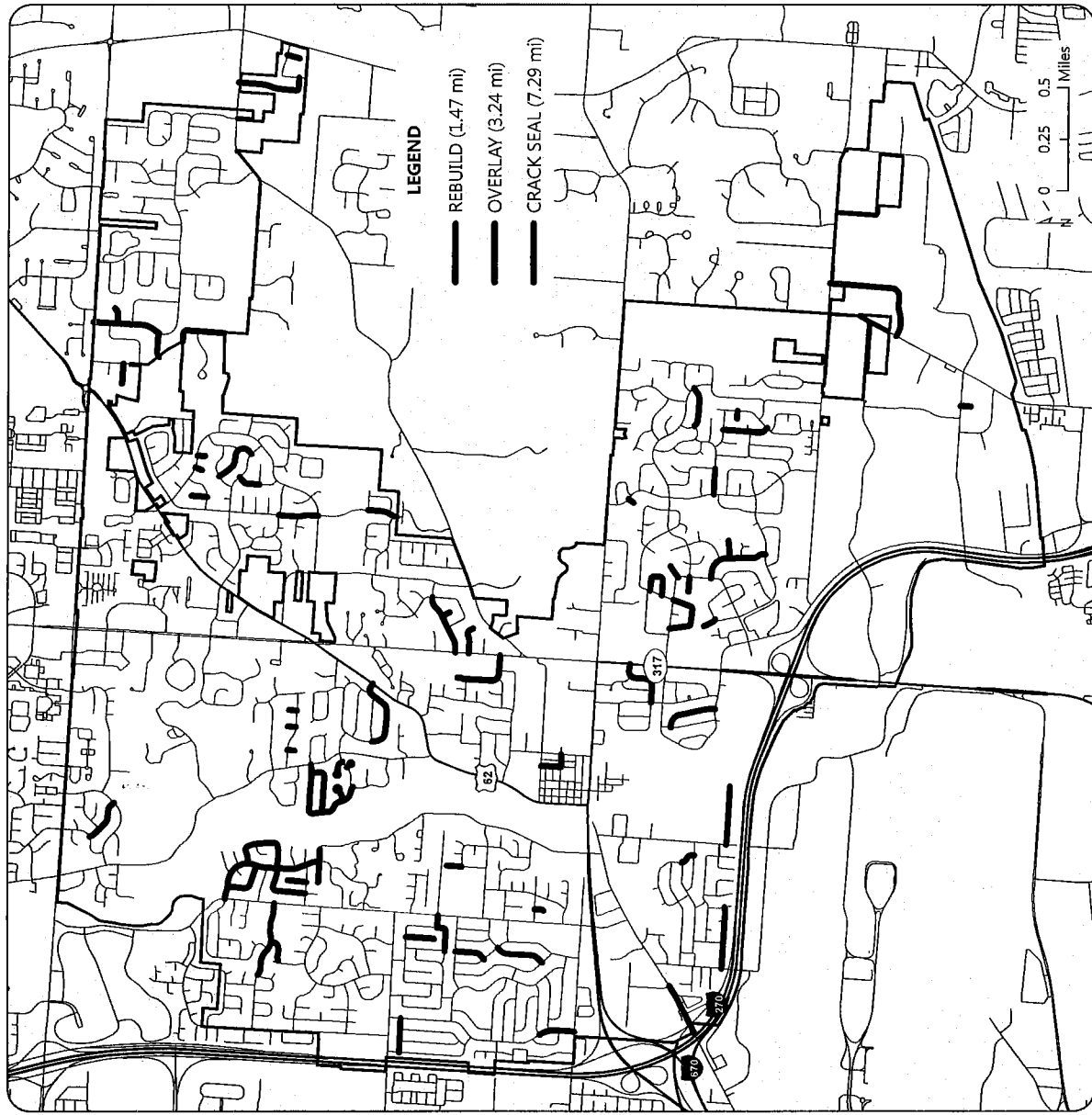

NOTE: This map is a resource to be used for general information purposes only. The City of Gahanna shall assume no liability for any errors, omissions, or inaccuracies in the information provided. All GIS data layers are referenced in the Ohio State Plane Coordinate System, Horizontal - North American Datum (NAD) 83 (95) Vertical - North American Datum Vertical Datum (NAD) 88, Units - Surveyors Feet. All data has been developed from public records that are constantly undergoing change and is not warranted for content, completeness, or accuracy. The City of Gahanna does not warrant, guarantee or represent the data to be fit for a particular use or purpose.

S:\Project\_Files\Yearly\Street\Programs\2018\Maps\Street-Program-2018.mxd Created: 02/16/2018



8 ft wide  
bike trail



Pavement Composition

- 2" Surface course
- 2" Intermediate course
- 4" 304 base

**SHULL ROAD BIKE TRAIL**

8 Ft wide bike trail to be installed on Shull Road, Starting from Morse Rd. To Greekway Court.



CITY OF GAHANNA

200 S. Hamilton Road  
Gahanna, Ohio 43230

Phone: (614) 342-4000  
Fax: (614) 342-4100  
www.gahanna.gov

Baroness Wy, Brookhaven Dr. E., Canterwood Ct,  
Foxwood/Denwood Dr. S., Gamewood Dr, Gary Lee Dr,  
Kenilworth Ct, Shepard St, Walnut St, Worman Dr

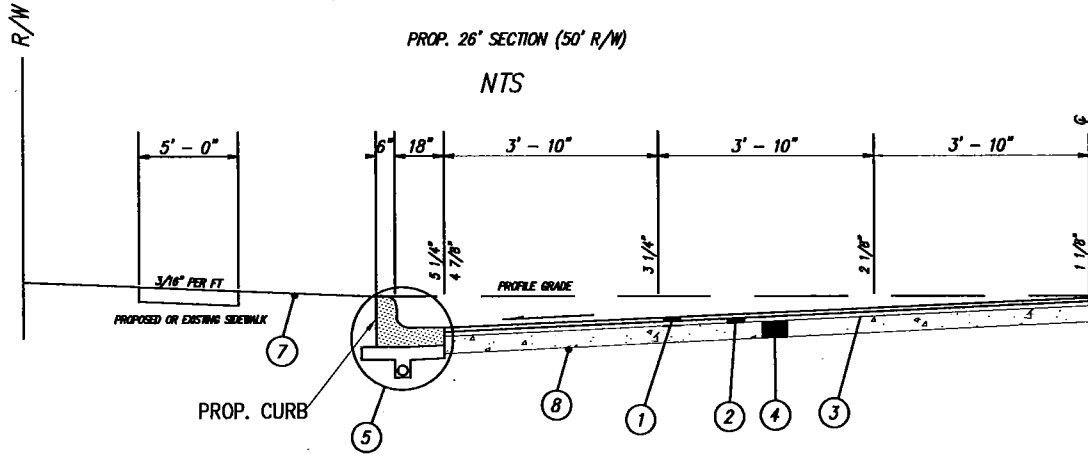

**LEGEND**

- ① 1-1/2" ASPHALT SURFACE COURSE, ITEM 448
- ② 1-1/2" ASPHALT INTERMEDIATE COURSE, ITEM 448
- ③ TACK COAT, ITEM 407 (APPLIED AT A RATE OF 0.1 GAL/SY)
- ④ 7" PORTLAND CEMENT CONCRETE BASE, ITEM 306
- ⑤ CONCRETE COMBINED CURB AND GUTTER INC. 4" UNDERDRAIN, ITEM 609 (SEE DETAIL)
- ⑥ 7" BITUMINOUS AGGREGATE BASE, ITEM 301 (APPLIED IN TWO 3-1/2" LIFTS)
- ⑦ TOPSOIL, SEEDING AND MULCHING, ITEM 653 & 659
- ⑧ 12" CEMENT BASE STABILIZATION, SPEC

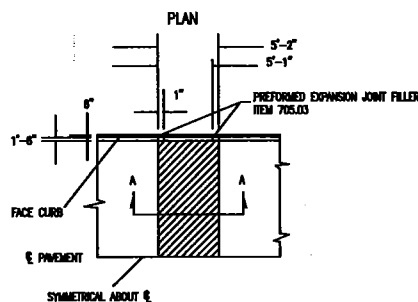

**EXPANSION JOINT**  
NTS

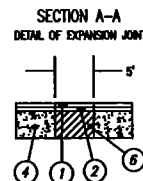

EXPANSION JOINTS SHALL BE CONSTRUCTED WHERE SHOWN ON THE PLANS.  
PAYMENT FOR THIS WORK WILL BE MADE AT THE UNIT BID PRICE PER ASPHALT EXPANSION JOINT.

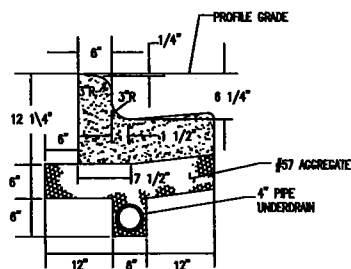

**COMBINATION CURB & GUTTER INC. 4" UNDERDRAIN**  
NTS

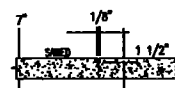

**CONTRACTION JOINT**  
NTS

MAXIMUM SPACING OF SAWED JOINTS SHALL BE 20'  
PAYMENT FOR THIS ITEM SHALL BE INCLUDED IN THE PRICE BID FOR ITEM 306, 7" CONCRETE BASE

Note: The contraction joint shall include the application of a self-adhering waterproofing membrane over the contraction joint immediately prior to surfacing. The membrane shall consist of a composite geotextile and rubberized asphalt material. The membrane shall extend over either side of the joint a minimum of six inches.

CITY OF GAHANNA/FRANKLIN COUNTY, OHIO  
**RECONSTRUCTION**

Baroness Wy, Brookhaven Dr. E., Canterwood Ct,  
Foxwood/Denwood Dr. S., Gamewood Dr, Gary Lee Dr,  
Kenilworth Ct, Shepard St, Walnut St, Worman Dr

Project No.: **ST-1054**

Date: **02/13/18**

Scale: **NONE**

Drawn By: **DGC**

Checked By:

**1**

# Appendix E

---

Contract



## CONTRACT

### 2018 STREET PROGRAM, ST-1054

This Contract made this \_\_\_\_\_ day of \_\_\_\_\_, 20 \_\_, by and between the City of Gahanna, Ohio, Party of the First Part, and:

\_\_\_\_\_  
(Party of the Second Part)

WITNESSETH:

ARTICLE 1. Said Party of the Second Part hereby agrees to furnish at its own cost and expense all equipment, labor, materials, and construction for the improvement as listed in the legal notices as required by the notice to bidders, information and requirements for bidders, general provisions, specifications, contract and all other required bid documents, therefore which are on file in the Department of Public Service of the municipal building of the City of Gahanna, Ohio, and which are each by reference made a part of this contract and attached hereto. All of the material and labor shall be furnished according to the requirements under this contract and to the satisfaction of the Department of Public Service and to the acceptance of the City of Gahanna, Ohio and at the prices set forth in the accompanying proposal which is made a part of this contract.

The Party of the First Part, in consideration of the full and faithful performance of all singular things herein, agrees that it will pay to said Party of the Second Part the prices and sums hereinabove written, payments to be made by said City upon estimates allowed by the Department of Public Service of the said city as the work progresses.

ARTICLE 2. Said Party of the First Part reserves the right to cancel this contract if either the funds for this contract are not appropriated by the Council of the City of Gahanna or the Party of the Second Part fails to meet the obligations or specifications under this contract.

IN TESTIMONY WHEREOF, the said parties hereunto set their hands the day and year first above written.

ATTEST:

CITY OF GAHANNA, OHIO

\_\_\_\_\_  
THOMAS R. KNEELAND  
Mayor

(Contractor must indicate whether Corporation, Partnership, Company or Individual. THE PERSON SIGNING SHALL IN OWN HANDWRITING, SIGN THE PRINCIPAL'S NAME, OWN NAME, AND TITLE. WHERE THE PERSON SIGNING FOR A CORPORATION IS OTHER THAN PRESIDENT, HE MUST SHOW AUTHORITY TO BIND THE CORPORATION BY AFFIDAVIT).

---

Party of the Second Part

---

Signature

---

Printed Name

---

Title

---

Address

---

City/State/Zip

I, Joann Bury, hereby certify that funds for this Contract are available and/or in the process of collection.

---

JOANN BURY  
Director of Finance

I, Shane Ewald, hereby approve the form and correctness of the foregoing Contract Bond and Contract.

---

SHANE EWALD  
City Attorney