



City of Gahanna
Department of Public Service and Engineering
200 South Hamilton Road • Gahanna, OH 43230
614.342.4050 Phone • 614.342.4100 Fax • www.gahanna.gov

INVITATION FOR BID

2019 STREET PROGRAM ST-1064

BID OPENING DATE: MARCH 29, 2019 AT 11:00AM, LOCAL TIME

Strawser Paving Company
Company Name Submitting Bid

1595 Frank Road
Street Address

Columbus, OH 43223
City, State, Zip

614-276-5273
Telephone Number

TABLE OF CONTENTS

	<u>Page</u>
Notice to Bidders	1
Information & Requirements for Bidders	2
Request for Information (Pre-Bid)	17
Appendix A: Supplementary Specifications	
Appendix B: Prevailing Wage (State)	
Appendix C: Documents to be Submitted with Bid	
Contractor's Qualificaiton Statement	
Subcontractors List	
Corporate Affidavit	
Contractor's Personal Property Tax Affidavit (O.R.C. §5719.042)	
Noncollusion Affidavit	
Escrow Waiver	
Bid Guaranty and Contract Bond (O.R.C. §153.571)	
Bid Form	
Appendix D: Detail Sheets, Typical Section, and 2019 Street Program Map	
Appendix E: Owner-Contractor Agreement & Administrative Project Documents	
Owner-Contractor Agreement	
Fiscal Officer's Statement of Availability	
Modified Standard General Conditions of the Construction Contract	
State of Ohio Bureau of Worker's Compensation Insurance Certificate Attachment Sheet	
Insurance Certificate Attachment Sheet	
Notice of Commencement of Public Improvement	
Notice of Award to Contractor	
Notice of Award to Surety and Surety's Agent	
Notice to Proceed	
Change Order	
Payroll Information	
Final Payroll Affidavit	
Contractor's Payment Application Checklist	
Contractor's Affidavit with Subcontractors List & Suppliers with any Amounts Withheld	
Contractor's Waiver and Release Agreement	
Subcontractor's/Supplier's Waiver & Release Agreement	
Statement of Claim Form	
Statement of Claim Form Instructions	
Design Professional's Certificate of Substantial Completion	
Appendix F: City of Columbus CMS Supplement	
CD: Bid Book, Bid Form, & Prevailing Wage Rates	

NOTICE TO BIDDERS

Sealed bids will be received by the City of Gahanna, Ohio ("Owner") until **11 am**, local time, on **March 29, 2019**, at the Director of Public Service and Engineering, 200 South Hamilton Road, Gahanna, Ohio 43230 [or] through the Owner's electronic bidding system for all labor, material, and services necessary for the **2019 Street Program, ST-1064** (the "Project"), as more fully described in the Contract Documents prepared by the City of Gahanna. Bids received after this time will not be accepted. Bids will be opened publicly and read immediately thereafter. Subject to the right of the Owner to reject any or all bids, the Owner will award contracts to the bidder(s) submitting the lowest and best bid(s). Direct questions about the Project to the City of Gahanna Director of Public Service and Engineering at (614)-342-4050.

Engineer's Estimate: \$3,657,879.20 (Base Bid)

The base bid Project consists of pavement milling, asphalt resurfacing, crack sealing, street rebuilds, and striping. It is anticipated that the work will commence on **May 1, 2019** and be completed by **August 13, 2019**.

Contract Documents are available for review in the office of the Director of Public Service and Engineering, 200 South Hamilton Road, Gahanna, Ohio 43230. Copies may be purchased for a non-refundable fee of **\$25.00**, payable to Owner.

All bids must be accompanied by a Bid Guaranty and Contract Bond for the full amount of the bid (including all add alternates) as described in the Information and Requirements for Bidders. If State or Federal Labor Standards Provisions and State Wage Decisions are applicable to this project it will be a part of the contract documents.

No Bidder may withdraw its bid within sixty (60) days after the bid opening. The Owner reserves the right to waive irregularities in bids, to reject any or all bids, and to conduct such investigation as necessary to determine the lowest and best bidder for each contract.

Robert Priestas, Director of Public Service and Engineering

Advertise: March 14, 2019 & March 21, 2019

INFORMATION AND REQUIREMENTS FOR BIDDERS

Information and Requirements for Bidders Coversheet (the "Coversheet")

Each Bidder shall be responsible for submitting its Bid in accordance with the instructions in this Information and Requirements for Bidders, for the bid opening, before **11 AM** (local time) on **March 29, 2019** (the "Bid Deadline").

Sealed bids will be received by the Owner until the bid opening at the office of the Director of Public Service and Engineering or through the Owner's electronic bidding system. Bids received after this time will not be accepted.

If a bidder is submitting a paper bid, the bid must be enclosed and delivered in a sealed opaque envelope addressed to the Director of Public Service and Engineering, 200 South Hamilton Road, Gahanna, Ohio 43230 with the bidder's name, bidder's address and title of the Contract plainly printed in the upper left hand corner. Each Bidder shall submit 1 copy of its bid to the Owner. Each Bidder shall be responsible for delivering its Bid to this office and address before the Bid Deadline.

If submitting through the Owner's electronic bidding system, the bid must be submitted via Bid Express at www.bidexpress.com. Vendors new to the City's electronic bidding system will need to register with Bid Express and create an account. Each Bidder shall be responsible for submitting its electronic Bid as instructed by the Owner, before the Bid Deadline.

The Design Professional (referred to as the "Design Professional" or "Engineer" in the Contract Documents) is:
N/A

The Project and Work for the Project consists of all labor, materials, equipment, and services necessary for the 2019 Street Program, ST-1064 (the "Project").

The Date for Substantial Completion is August 13, 2019.

The total estimated construction cost for the base bid Work on the Project for which bids are being solicited at this time is \$3,657,879.20

A complete set of the Contract Documents is available for examination, without charge, at the Office of the Director of Public Service and Engineering, 200 South Hamilton Road, Gahanna, Ohio 43230 during its normal business hours.

- A. BIDDER'S PLEDGE AND AGREEMENT
- B. EXAMINATION OF CONTRACT DOCUMENTS AND SITE CONDITIONS AND RELIANCE UPON TECHNICAL DATA
- C. OWNER & DESIGN PROFESSIONAL
- D. PROJECT
- E. WORK
- F. ESTIMATE OF COST
- G. CONTRACT DOCUMENTS
- H. PREPARATION OF BIDS
- I. METHOD OF AWARD
- J. EXECUTION OF CONTRACT
- K. SUBSTITUTIONS/NON-SPECIFIED PRODUCTS
- L. ALTERNATES
- M. UNIT PRICES
- N. ADDENDA
- O. INTERPRETATION
- P. STATE SALES AND USE TAXES
- Q. DATE FOR SUBSTANTIAL COMPLETION/LIQUIDATED DAMAGES
- R. OWNER'S RIGHT TO WAIVE DEFECTS AND IRREGULARITIES
- S. MODIFICATION/WITHDRAWAL OF BIDS
- T. COMPLIANCE WITH APPLICABLE LAWS
- U. FINDINGS FOR RECOVERY
- V. PREVAILING WAGES
- W. FEDERAL FUNDING
- X. OHIO PUBLIC WORKS COMMISSION FUNDING

A. BIDDER'S PLEDGE AND AGREEMENT

1. Each Bidder acknowledges that this is a public project involving public funds and that the Owner expects and requires that each successful Bidder adhere to the highest ethical and performance standards. Each Bidder by submitting a bid pledges and agrees that (a) it will act at all times with absolute integrity and truthfulness in its dealings with the Owner and the Design Professional, (b) it will use its best efforts to cooperate with the Owner and the Design Professional and all other Contractors on the Project and at all times will act with professionalism and dignity in its dealings with the Owner, Design Professional, and other Contractors, (c) it will assign only competent supervisors and workers to the Project, each of whom is fully qualified to perform the tasks that are assigned to him/her, and (d) it has read, understands and will comply with the terms of the Contract Documents.

B. EXAMINATION OF CONTRACT DOCUMENTS AND SITE CONDITIONS AND RELIANCE UPON TECHNICAL DATA

1. Each Bidder shall have a competent person carefully and diligently review each part of the Contract Documents, including the Divisions of the Specifications and parts of the Drawings that are not directly applicable to the Work on which the Bidder is submitting its bid. By submitting its bid, each Bidder represents and agrees, based upon its careful and diligent review of the Contract Documents, that it is not aware of any conflicts, inconsistencies, errors, or omissions in the Contract Documents for which it has not notified the Design Professional in writing at least seven (7) days prior to the bid opening. If there are any such conflicts, inconsistencies, errors, or omissions in the Contract Documents, the Bidder (i) will provide the labor, equipment, or materials of the better quality or greater quantity of Work and/or (ii) will comply with the more stringent requirements. The Bidder will not be entitled to any additional compensation for any conflicts, inconsistencies, errors, or omissions that would have been discovered by such careful and diligent review, unless it has given prior written notice to the Design Professional.
2. Each Bidder shall have a competent person carefully and diligently inspect and examine the entire site and the surrounding area, including all parts of the site applicable to the Work for which it is submitting its bid, including location, condition, and layout of the site and the location of utilities, and carefully correlate the results of the inspection with the requirements of the Contract Documents. The Bidder's bid shall include all costs attributable to site and surrounding area conditions that would have been discovered by such careful and diligent inspection and examination of the site and the surrounding area, and the Bidder shall not be entitled to any Change Order, additional compensation, or additional time on account of such conditions.
3. The Bidder may rely upon the general accuracy of any technical data included in the Project Manual (e.g., soils exploration reports, soil boring logs, site survey, or abatement reports) in preparing its bid, but such technical data are not part of the Contract Documents. Except for the limited reliance described in the preceding sentence, Bidder may not, if awarded a contract for the Work, rely upon or make any Claim against the Owner or Design Professional, or any of their agents or employees, with respect to any of the following:
 - (a) the completeness of such reports and drawings for Bidder's purposes, including, but not limited to, any aspects of the means, methods, techniques, sequences, and procedures of construction to be employed by the successful Bidder and safety precautions and programs incident thereto;
 - (b) other data, interpretations, opinions, and information contained in such reports or shown or indicated in such drawings; or

- (c) any interpretation by the successful Bidder of or conclusion drawn from any technical data or any such other data, interpretations, opinions, or information. For example, all interpolations and extrapolations of data performed by the Bidder to estimate locations or quantities of subsurface strata are independent factual assumptions, which Owner does not warrant.
- 4. Each Bidder will be deemed to have actual knowledge of all information provided or discussed at the pre-bid meeting.

C. OWNER & DESIGN PROFESSIONAL

- 1. The Owner is:
 - City of Gahanna
 - Telephone: 614-342-4050
 - Fax: 614-342-4100

The Owner's Representative is Robert Priestas.

- 2. The Design Professional (referred to as the "Design Professional" or "Engineer" in the Contract Documents) is set forth in the Coversheet.

D. PROJECT

- 1. The Project and Work for the Project consists of all labor, materials, equipment, and services necessary for the Project as identified in the Coversheet, all in accordance with the Drawings and Specifications prepared by the Design Professional. The Project will be substantially complete by the Date for Substantial Completion, identified in the Coversheet.

E. WORK

- 1. The Project consists of the contract(s) for work on the Project identified in the Coversheet. Individual bid package estimates are provided for the Bidder's information only.

F. ESTIMATE OF COST

- 1. The total estimated construction cost for the base bid Work on the Project for which bids are being solicited at this time is set forth in the Coversheet.

G. CONTRACT DOCUMENTS

1. The Contract Documents consist of the Contract Documents listed in Section 1 of the Owner-Contractor Agreement.

A complete set of the Contract Documents is available for examination, without charge, at the Office of the Director of Public Service and Engineering, 200 South Hamilton Road, Gahanna, Ohio 43230 during its normal business hours, as well as the following locations during normal business hours:

As identified in the Coversheet.

Bidders shall use complete sets of Contract Documents in preparing bids. Neither the Owner nor the Design Professional assumes any responsibility for errors or misinterpretations resulting from the use of incomplete sets of Contract Documents.

The Owner or the Design Professional, in making the Contract Documents available on the above terms, does so only for the purpose of obtaining bids on the Work and does not confer a license or grant for any other use.

H. PREPARATION OF BIDS

1. All bid documents must be completed and submitted at the time of the bid opening including but not limited to a Bid Guaranty. See Section H.6 and H.8 below. All bids must be submitted on the Bid Form furnished with the Contract Documents.
2. Fill in all blank spaces, in ink or typewritten, in words and figures, and in figures only where no space is provided for words: sign the Bid Form. The wording on the Bid Form shall be used without change, alteration, or addition. Any change in the wording or omission of specified accompanying documents may cause the bid to be rejected. If there is an inconsistency or conflict in the bid amount, the lowest amount shall control, whether expressed in numbers or words.
3. Bidders shall note receipt of all Addenda on the Bid Form. If the Bidder fails to acknowledge receipt of each Addendum, the Bid shall be deemed non-responsive, unless the Bid amount clearly and unambiguously reflects receipt of the Addendum or the Addendum involves only a matter of form and does not affect the price, quantity, or quality of the Work to be performed in any material manner.
4. Each Bidder shall submit the number of copies of its bid to the Owner as set forth in the Coversheet. The Bid Form shall be signed with the name typed or printed below the signature. A Bid shall not be submitted by facsimile transmission. A Bidder that is a corporation shall sign its bid with the legal name of the corporation followed by the name of the state of incorporation and the legal signature of an officer authorized to bind the corporation to a contract.
5. Each Bid shall be enclosed and delivered in a sealed opaque envelope with the Bidder's name and the title of the Project printed in the upper left hand corner and addressed as follows: **Director of Public Service and Engineering, 200 South Hamilton Road, Gahanna, Ohio 43230**. The Bidder shall be responsible for delivering its Bid to this office and address for the bid opening before the Bid Deadline identified in the Coversheet.

If the Bidder is using a third party, e.g., Federal Express, to deliver its bid, the Bidder must comply with this provision by including on the outside packing envelope the foregoing information (i.e., the Bidder's name, the title of the Project, and the following phrase: "this

package contains a bid – deliver immediately”). This information shall be printed in the upper left hand corner of the envelope.

If a bidder is submitting an electronic bid via the Owner’s electronic bidding system, the bid must be submitted via Bid Express at www.bidexpress.com. Vendors new to the City’s electronic bidding system will need to register with Bid Express and create an account.

The bid opening shall be extended one (1) week if any addenda is issued within a seventy-two (72) hour period prior to the bid opening, excluding Saturdays, Sundays and legal holidays, with no further advertising of bids required unless otherwise noted in the addendum. It is the sole responsibility of the bidder to ensure that their bid is received in the proper time before the bid deadline.

6. The completed Bid Form shall be accompanied by the following documents: Contractor’s Qualification Statement, Subcontractors List, Corporate Affidavit, Contractor’s Personal Property Tax Affidavit, Noncollusion Affidavit, Escrow Waiver, Bid Certification, Bid Guaranty and Contract Bond (including Power of Attorney, Surety Financial Statement and Certificate of Compliance for Ohio), Bid Form, Clarifications (if issued) and Addenda (if issued). Any change in the wording or omission of specified accompanying documents may cause the bid to be rejected.
7. The Bidder shall take the following precautions in preparing its bid:
 - a. Sign the bid and check to insure all blank spaces have been filled in with requested information and the specified accompanying documents (listed in Item 6 above) have been included in a sealed opaque envelope addressed as described in Item 5 above.
 - b. When the Bid Form provides for quoting either an addition or deduction for an Alternate item, indicate whether the sum named is an addition or deduction. If it is not indicated, it will be conclusively presumed that the amount is a deduction.
 - c. When the Bid Form provides for quoting a unit price, the Bidder should quote the unit price as set forth in the Bid Documents.
 - d. When applicable, make sure that the Bid Guaranty is properly executed and signed by:
 - 1) The Bidder
 - 2) The Surety or Sureties
 - e. The form of Bid Guaranty must be a Bid Guaranty and Contract Bond and the amount may be left blank; if an amount is inserted, it must equal the total of the base bid and all add alternates included. If an amount is inserted, the failure to state an amount equal to or greater than the total of the base bid and all add alternates that are accepted shall make the bid non-responsive.
 - f. Make sure that the appropriate bid package and scope of work is inserted in the correct space on the Bid Guaranty and Contract Bond Form. Failure to include work covered by the bid submitted may make the bid non-responsive.
 - g. Combination Bids. The Owner may provide the option of submitting a combination bid on the Bid Form.
 - (1) When there is an option for submitting a combination bid on the Bid Form, a Bidder desiring to submit a combination bid for two or more bid packages shall include both of the following on the Bid Form:
 - (a) the combination bid amount in the space provided, identifying the bid packages included in the combination bid amount; AND

- (b) separate base bids for each bid package, including alternates, included in the combination bid in the places provided on the Bid Form for the individual bid packages.

NOTE: The individual cost amounts of each base bid need not total the combination bid amount.

8. Bonds and Guarantees

- a. Bid Guaranty: Bidder shall furnish a Bid Guaranty, in the form of a bond for the full amount of the bid in the form of the Bid Guaranty and Contract Bond included in the Contract Documents. Failure to include the Bid Guaranty in such form may make the bid non-responsive. The Bid amount shall be the total of all sums bid, including all add alternates with no deduction for any deduct alternates. NOTE: AIA Bid Bond forms are not acceptable. Alternate bid guaranty forms are not acceptable.
- b. The bond must be issued by a surety company ("Surety") authorized by the Ohio Department of Insurance to transact business in the State of Ohio and acceptable to the Owner. The bond must be issued by a Surety capable of demonstrating a record of competent underwriting, efficient management, adequate reserves, and sound investments. These criteria will be deemed to be met if the Surety currently has an A.M. Best Company Policyholders Rating of "A-" better and has or exceeds the Best Financial Size Category of Class VI. Other Sureties may be acceptable to the Owner, in its sole discretion.
- d. All bonds shall be signed by an authorized agent of an acceptable Surety and by the Bidder.
- e. Surety bonds shall be supported by credentials showing the Power of Attorney of the agent, a certificate showing the legal right of the Surety to do business in the State of Ohio, and a financial statement of the Surety.
- f. The Bid Guaranty, as applicable, shall be in the name of or payable to the order of the Owner.
- g. The name, address, and telephone and fax numbers of the Surety and the Surety's Agent should be typed or printed on each bond.

I. METHOD OF AWARD

- 1. All bids shall remain open for acceptance for sixty (60) days following the day of the bid opening, but the Owner may, in its sole discretion, release any bid and return the Bid Guaranty prior to that date. The Bid Guaranty shall be subject to forfeiture, as provided in the Ohio Revised Code, if a bid is withdrawn during the period when bids are being held.
- 2. The Owner reserves the right to reject any, part of any, or all bids and to waive any informalities and irregularities. The Bidder expressly acknowledges this right of the Owner to reject any or all bids or to reject any incomplete or irregular bid. The Owner will award a single contract for each of the bid packages listed above or one or more combined contracts for combinations of the Bid Packages, unless it determines to reject one or more bid packages. Bidders must furnish all information requested on or accompanying the Bid Form. Failure to do so may result in disqualification of the bid.
- 3. Determination of the Bidder Submitting the Lowest and Best Bid. Subject to the right of the Owner to reject any or all bids, the Owner will award the Contract for the Work to the Bidder submitting the lowest and best bid, taking into consideration accepted alternates. In evaluating bids, the Owner may consider the qualifications of the Bidders, whether or not the

bids comply with the prescribed requirements, and alternates and unit prices, if requested, on the Bid Form. The Owner may also consider the qualifications and experience of subcontractors and suppliers. The Owner may conduct such investigations as are deemed necessary to establish the qualifications and financial ability of the Bidder and its subcontractors and suppliers. The factors the Owner may consider in determining which Bidder submitted the lowest and best bid or which Bidders submitted the lowest and best bids include the factors set forth below. The Owner, in its discretion, may consider and give such weight to these criteria as it deems appropriate.

- a. The Bidder's work history. The Bidder should have a record of consistent customer satisfaction and of consistent completion of projects, including projects that are comparable to or larger and more complex than the Owner's Project, on time and in accordance with the applicable Contract Documents, and the Bidder's claims history. If the Bidder's management operates or has operated another construction company, the Owner may consider the work history of that company in determining whether the Bidder submitted the lowest and best bid.

The Owner may consider the Bidder's prior experience on other projects with the Owner and Design Professional, including the Bidder's demonstrated ability to complete its work on these projects in accordance with the Contract Documents and on time, and will also consider its ability to work with the Owner and Design Professional as a willing, cooperative, and successful team member.

The Bidder authorizes the Owner and its representatives to contact the owners and design professionals (and construction managers, if applicable) on projects on which the Bidder has worked and authorizes and requests such owners and design professionals (and construction managers) to provide the Owner with a candid evaluation of the Bidder's performance. By submitting its bid, the Bidder agrees that if it or any person, directly or indirectly, on its behalf or for its benefit brings an action against any of such owners or design professionals (or construction managers) or the employees of any of them as a result of or related to such candid evaluation, the Bidder will indemnify and hold harmless such owners, design professionals (and construction managers) and the employees of any of them from any claims whether or not proven that are part of or are related to such action and from all legal fees and expenses incurred by any of them arising out of or related to such legal action. This obligation is expressly intended for the benefit of such owners, design professionals (and construction managers), and the employees of each of them.

- b. The Bidder's financial ability to complete the Contract successfully and on time without resort to its Surety.
- c. The Bidder's prior experience with similar work on comparable or more complex projects.
- d. The Bidder's prior history for the successful and timely completion of projects, including the Bidder's history of filing and having claims filed against it.
- e. The Bidder's equipment and facilities.
- f. The adequacy, in numbers and experience, of the Bidder's work force to complete the Contract successfully and on time.
- g. The Bidder's compliance with federal, state, and local laws, rules, and regulations, including but not limited to the Occupational Safety and Health Act, the Ohio Prevailing Wage laws, and Ohio ethics laws.

- h. The foregoing information with respect to each of the Subcontractors and Suppliers that the Bidder intends to use on the Project.
 - i. The Bidder's participation in a drug-free workplace program acceptable to the Owner, and the Bidder's record for both resolved and unresolved findings of the Auditor of State for recovery as defined in Section 9.24 of the Ohio Revised Code.
 - j. The Owner's prior experience with the Bidder's surety.
 - k. The Bidder's interest in the Project as evidenced by its attendance at any pre-bid meetings or conferences for bidders.
 - l. The Bidder's ability to self-perform the work on the Project with the Bidder's own forces.
 - m. Depending upon the type of the work, other essential factors, as the Owner may determine and as are included in the Specifications.
4. Within three (3) business days after the Owner's identification of the apparent low bidder, if requested, the apparent low bidder will complete and submit to the Design Professional a completed Contractor's Qualification Statement (using the form included in the Project Manual), and thereafter will provide the Design Professional with such additional information as the Design Professional may request regarding the Bidder's qualifications. Additionally, upon request from the Design Professional, any other Bidder will promptly complete and submit to the Design Professional a completed Contractor's Qualification Statement and thereafter will provide the Design Professional with such additional information as the Design Professional may request regarding the Bidder's qualifications. A Bidder will submit any requested information within three (3) business days of the date of the request.
5. The failure to submit requested information on a timely basis may result in the determination that the Bidder is not the lowest and best bidder.
6. By submitting its bid, the Bidder agrees that the Owner's determination of which bidder is the lowest and best bidder shall be final and conclusive, and that if the Bidder or any person or association on its behalf challenges such determination in any legal proceeding, the Bidder shall indemnify and hold the Owner and its employees and agents harmless from any claims included in or related to such legal proceeding, whether or not proven, and from legal fees and expenses incurred by the Owner, its employees, or agents that arise out of or are related to such challenge.
7. Within three (3) business days of receipt of the bids or such longer time as may be permitted in writing by the Design Professional, the apparent low Bidder will submit a list of all proposed Subcontractors and Suppliers.

After approval by the Owner and Design Professional of the list of proposed Subcontractors, Suppliers, and manufactures submitted by the successful Bidder, the list shall not be changed unless written approval of the change is authorized by the Owner and Design Professional.
8. Affidavit as to Personal Property Taxes. Each successful Bidder shall submit, prior to the time of the entry into the Contract, an affidavit in the form required by Section 5719.042, Ohio Revised Code, regarding the status of the Bidder's personal property taxes. A copy of the affidavit form is included with the Contract Documents.
9. No Bidder may withdraw its bid within sixty (60) days after the date bids are opened. The Owner reserves the right to waive any formalities or irregularities or to reject any or all bids.
10. The Owner reserves the right to disqualify bids, before or after opening, upon evidence of collusion with intent to defraud or other illegal practices on the part of the Bidder.

11. Award of Contract. The award of the Contract, when required, will only be made pursuant to a duly adopted resolution of the Owner.

J. EXECUTION OF CONTRACT

1. Within 10 days after award of the Contract, the successful Bidder shall execute and deliver to the Design Professional the required number of copies of the Owner-Contractor Agreement, in the form included in the Contract Documents, and all accompanying documents requested, including, but not limited to, a Contract Bond (if applicable), insurance certificates, and a valid Workers' Compensation Certificate. The award of Contract notwithstanding, the successful Bidder shall have no property interest or rights under the Owner-Contractor Agreement until such time as the Owner-Contractor Agreement is executed by the successful bidder and the Owner.

K. SUBSTITUTIONS/NON-SPECIFIED PRODUCTS

1. Certain brands of material or apparatus are specified. Each bid will be based on these brands, which may be referred to in the Contract Documents as Standards. The use of another brand (referred to as a substitution or proposed equal in the Contract Documents, when a bidder or the contractor seeks to have a different brand of material or apparatus than that specified approved by the Owner for use in the Project) may be requested as provided herein. Substitutions, however, will not be considered in determining the lowest and best bid.
2. The products specified in the Contract Documents establish a standard of required function, dimension, appearance, and quality.
3. Bidders wishing to obtain approval to bid non-specified products shall submit written requests to the Design Professional a minimum of ten (10) working days before the bid date and hour. To facilitate the submission of requests, a Substitution Form is included in the Bid Documents. The Bidder shall include the name of the material or equipment for which it is to be substituted and a complete description of the proposed substitution, including the name of the proposed manufacturer and/or product and a complete description of the proposed product including manufacturer's name and model number or system proposed, drawings, product literature, performance and test data, color selections or limitations, and any other information necessary for evaluation. Include a statement including any changes in other materials, equipment, or other work that would be required if the proposed product is incorporated in the materials, equipment, or other work that would be required if the proposed product is incorporated in the work. The burden of proof of the merit of the proposed product is on the proposer. The Design Professional's decision on approval of a proposed product will be final.

The following will be cause for rejection of a proposed substitution:

- a. Requests submitted by subcontractors, material suppliers, and individuals other than Bidders;
 - b. Requests submitted without adequate documentation;
 - c. Requests received after the specified cut-off date.
4. When the Design Professional approves a product submission before receipt of bids, the approval will be included in an Addendum, and Bidders may include the pricing of this product in their bid. Bidders shall not rely on approvals made in any other manner.
 5. In proposing a non-specified product or a substitution, the Bidder represents and warrants that each proposed product will not result in any changes to the Project, including changes to

the Work of other contractors, or any decrease in the performance of any equipment or systems to be installed in the Project and agrees to pay any additional costs incurred by the Owner and the Owner's consultants as a result of a non-specified or substitute product that is accepted.

6. Following the award of the Contract, there shall be no substitutions for specified products, except pursuant to a Change Order. The Owner in its sole discretion may decline to consider a substitution for a Change Order.

L. ALTERNATES

1. The Owner may request bids on alternates. If the Owner requests bids on alternates, the Bidder should include the cost of the alternates requested on its Bid Form.
2. At the time of awarding the contract, the Owner will select or reject alternates as it determines is in its best interest. A Bidder's failure to include on its Bid Form the cost of an alternate selected by the Owner and applicable to the Bidder's work shall render the bid non-responsive and be grounds for the rejection of the bid. Otherwise, the failure to include the cost of an alternate will not be deemed material.
3. The Bidder acknowledges that although there is an estimate for the cost of the Project, the market conditions may and frequently do result in the estimate being different from the sum of the bids received, either higher or lower. The Bidder understands that the Owner may include alternates, which may include deduct alternates as well as add alternates, to give it flexibility to build the Project with the funds available. The Bidder further understands and acknowledges that use of add and deduct alternates is a long held customary practice in the construction industry in the State of Ohio. The Bidder also acknowledges that the Owner will not make a decision about the alternates on which to base the award of contracts until the bids are received, and the Owner can compare its available funds with the base bids and the cost or savings from selecting different alternates. The Bidder understands that the award to the Bidder submitting the lowest and best bid will be based on the lowest base bid plus selected alternates, and may result in an award to a Bidder other than the Bidder that submitted the lowest base bid.
4. If, during the progress of the Work, the Owner desires to reinstate any alternate not included in the Contract, the Owner reserves the right to reinstate the alternate at the price bid by the Contractor provided that such action is taken in sufficient time so as not to delay the progress of the work or cause the Contractor additional expense.

M. UNIT PRICES

1. Where unit prices are requested in the Bid Form for a Prime Contract on which the Bidder submits a bid, the Bidder should quote a unit price. Unless otherwise expressly provided in the Bid Documents, such unit prices shall include all labor, materials, and services necessary for the timely and proper installation of the item for which the unit prices are requested. The unit prices quoted in the bid shall be the basis for any Change Orders entered into under the Owner-Contractor Agreement, unless the Design Professional determines that the use of such unit prices will cause substantial inequity to either the Contractor or the Owner.

N. ADDENDA

1. The Owner reserves the right to issue Addenda changing, altering, or supplementing the Contract Documents prior to the time set for receiving bids. Addenda may be issued to clarify bidders' questions and/or to change, alter, or supplement the Contract Documents.

2. Any explanation, interpretation, correction, or modification of the Contract Documents will be issued in writing in the form of an Addendum, which shall be the only means considered binding; explanations, interpretations, etc., made by any other means shall NOT be legally binding. All Addenda shall become a part of the Contract Documents.
3. Bidders shall submit written questions to the Design Professional in sufficient time in advance of the bid opening to allow sufficient time for the Design Professional to respond. The Owner—after consultation with the Design Professional—shall in its sole discretion determine whether or not an Addendum will be issued. All Addenda will be issued, except as hereafter provided, and emailed (unless a different delivery method is requested) to persons who have obtained Contract Documents for the Project, at least seventy-two (72) hours prior to the published time for the opening of bids, excluding Saturdays, Sundays, and legal holidays. If any Addendum is issued within such seventy-two (72) hour period, then the time for opening of bids shall be extended one (1) week with no further advertising of bids required unless otherwise noted in the Addendum.
4. Copies of each Addendum will be sent only to the Bidders to whom Contract Documents have been issued and to Plan Rooms where copies of the Contract Documents are maintained. Receipt of Addenda shall be indicated by Bidders in the space provided on the Bid Form. Bidders are responsible for acquiring issued Addenda in time to incorporate them into their bid. Bidders should contact the Design Professional prior to the bid opening to verify the number of Addenda issued.
5. Each Bidder shall carefully read and review the Contract Documents and immediately bring to the attention of the Design Professional any error, omission, inconsistency, or ambiguity therein.
6. If a Bidder fails to indicate receipt of all Addenda through the last Addendum issued by the Design Professional on its Bid Form, the bid of such Bidder will be deemed to be responsive only if:
 - a. The bid received clearly indicates that the Bidder received the Addendum, such as where the Addendum added another item to be bid upon and the Bidder submitted a bid on that item; or
 - b. The Addendum involves only a matter of form or is one which has either no effect or has merely a trivial or negligible effect on price, quantity, quality, or delivery of the item bid upon.

O. INTERPRETATION

1. If a Bidder contemplating submitting a bid for the proposed Project is in doubt as to the true meaning of any part of the Contract Documents, it may submit a written request for an interpretation thereof to the Design Professional a minimum of five (5) business days prior to the Bid opening date. Any interpretation of the proposed documents will be made by Addendum only, duly signed by the Design Professional, and a copy of such Addendum will be delivered to each Bidder receiving a set of Contract Documents or that has asked to be added to the plan holders list. Addenda and clarifications will be sent via email, unless a different delivery method is requested. The Owner will not be responsible for any other explanation or interpretation of the proposed documents.
2. In interpreting the Contract Documents, words describing materials that have a well-known technical or trade meaning, unless otherwise specifically defined in the Contract Documents, shall be construed in accordance with the well-known meaning recognized by the trade.

3. Bidders are responsible for notifying the Design Professional in a timely manner of any ambiguities, inconsistencies, errors, or omissions in the Contract Documents. The Bidder shall not, at any time after the execution of the Contract, be compensated for a claim alleging insufficient data, incomplete Contract Documents, or incorrectly assumed conditions regarding the nature or character of the Work, if no request was made by the Bidder prior to the bid opening.

P. STATE SALES AND USE TAXES

1. The Owner is a political subdivision of the State of Ohio and is exempt from taxation under the Ohio Sales Tax and Use Tax Laws. Building materials that the successful Bidder purchases for incorporation into the Project will be exempt from state sales and use taxes if the successful Bidder provides a properly completed Ohio Department of Taxation Construction Contract Exemption Certificate to the vendors or suppliers when the materials are acquired. The Owner will execute properly completed certificates on request.

Q. DATE FOR SUBSTANTIAL COMPLETION/LIQUIDATED DAMAGES

1. Date for Substantial Completion. Each successful Bidder shall have its Work on the Project Substantially Complete (as Substantial Completion is defined in the Contract Documents) by the Date of Substantial Completion set forth in the Coversheet, or within the Contract Time, as applicable to the Bidder's scope of work.

The Contract Time shall run from the date of the Notice to Proceed or if there is no Notice to Proceed from the Effective Date of the Owner- Contractor Agreement. The Date for Substantial Completion Date and the Contract Time may be extended only by Change Order, by other Modification, or by a Claim that is Finally Resolved. By submitting its Bid, each Bidder agrees that the period for performing its Work is reasonable.

2. Liquidated Damages. If the successful Bidder does not have its Work Substantially Complete by its Date for Substantial Completion and/or Finally Complete within forty-five (45) days of achieving Substantial Completion, whichever may be applicable, the successful Bidder shall pay the Owner and the Owner may set off from amounts otherwise due the successful Bidder Liquidated Damages. The daily amounts of Liquidated Damages are set forth in the tables included in the Owner-Contractor Agreement. The total amounts of Liquidated Damages will be calculated based on the total number of calendar days beyond the Date for Substantial Completion that the Bidder's Work is not Substantially Complete and/or to the extent that its Work is not Finally Complete more than forty-five (45) after the Substantial Completion of its Work, i.e., number of late days times the per diem rate(s) for Liquidated Damages in the tables. In addition to such Liquidated Damages, the Bidder shall indemnify, defend, and hold the Owner and its employees and agents harmless from any and all claims, whether or not such claims are proven, and from all costs and expenses incurred as a result of such claims, including but not limited to attorneys' and consultants' fees and expenses, that arise out of or are related to the Bidder's failure to Substantially Complete its Work by its Date for Substantial Completion. The Bidder's obligations under this Section are joint and several.
3. The Bidder acknowledges and agrees, by submitting its bid for the Work and entering into a Contract with the Owner, that such amounts of Liquidated Damages represent a reasonable estimate of the actual damages for loss of or interference with the intended use of the Project that the Owner would incur if the Bidder's Work is not Substantially Complete by its Date for Substantial Completion and/or not Finally Complete by forty-five (45) days of the Date of Substantial Completion. The Bidder further acknowledges, agrees and understands that it may seek an extension of the Contract Time (and its Date for Substantial Completion) to

avoid or reduce Liquidated Damages by properly following the Claim procedures in the Contract Documents.

R. OWNER'S RIGHT TO WAIVE DEFECTS AND IRREGULARITIES

1. The Owner reserves the right to waive any and all irregularities provided that the defects and irregularities do not affect the amount of the bid in any material respect or otherwise give the Bidder a competitive advantage.

S. MODIFICATION/WITHDRAWAL OF BIDS

1. Modification. A Bidder may modify its bid by written communication to the Owner addressed to the Owner's Representative at any time prior to the scheduled closing time for receipt of bids, provided such written communication is received by Owner's Representative prior to the bid deadline. The written communication shall not reveal the bid price, but should provide the addition or subtraction or other modification so that the final prices or terms will not be known until the sealed bid is opened. If the Bidder's written instructions with the change in bid reveal the bid amount in any way prior to the bid opening, the bid may be rejected as non-responsive.
2. Withdrawal Prior to Bid Deadline. A Bidder may withdraw its bid at any time for any reason prior to the bid deadline for the opening of bids established in the Legal Notice. The request to withdraw shall be made in writing to and received by the Owner's Representative prior to the time of the bid opening.
3. Withdrawal after Bid Deadline.
 - a. All bids shall remain valid and open for acceptance for a period of at least 60 days after the bid opening; provided, however, that a Bidder may withdraw its bid from consideration after the bid deadline when all of the following apply:
 - (1) the price bid was substantially lower than the other bids;
 - (2) the reason for the bid being substantially lower was a clerical mistake, rather than a mistake in judgment, and was due to an unintentional and substantial error in arithmetic or an unintentional omission of a substantial quantity of work, labor, or material;
 - (3) the bid was submitted in good faith; and
 - (4) the Bidder provides written notice to the Owner, to the attention of the Owner's Representative, within two (2) business days after the bid opening for which the right to withdraw is claimed.
 - b. No bid may be withdrawn under this provision if the result would be the awarding of the contract on another bid for the bid package from which the Bidder is withdrawing its bid to the same Bidder.
 - c. If a bid is withdrawn under this provision, the Owner may award the Contract to another Bidder determined by the Owner to be the lowest and best bidder or the Owner may reject all bids and advertise for other bids. In the event the Owner advertises for other bids, the withdrawing Bidder shall pay the costs incurred in connection with the rebidding by the Owner, including the cost of printing new Contract Documents, required advertising, and printing and mailing notices to prospective bidders, if the Owner finds that such costs would not have been incurred but for such withdrawal.

T. COMPLIANCE WITH APPLICABLE LAWS

1. By submitting a bid for Work on the Project, the Bidder acknowledges that it is in compliance with applicable federal, state, and local laws and regulations, including, but not limited to, the following:
 - a. Equal Employment Opportunity/Nondiscrimination. The Bidder agrees that if it is awarded a contract that in the hiring of employees for performance of work under the contract or any subcontract, neither it nor any subcontractor, or any person acting on its behalf or its subcontractor's behalf, by reason of race, creed, sex, disability as defined in Section 4112.01 of the Ohio Revised Code, or color, shall discriminate against any citizen of the state in the employment of labor or workers who are qualified and available to perform work to which the employment relates. The Bidder further agrees that neither it nor any subcontractor or any person on its behalf or on behalf of any subcontractor, in any manner, shall discriminate against or intimidate any employees hired for the performance of the work under the contract on account of race, creed, sex, disability as defined in Section 4112.01 of the Ohio Revised Code, or color.
 - b. Ethics Laws. The Bidder represents that it is familiar with all applicable ethics law requirements, including without limitation Sections 102.04 and 3517.13 of the Ohio Revised Code, and certifies that it is in compliance with such requirements.

U. FINDINGS FOR RECOVERY

1. By submitting its bid, each Bidder certifies for reliance of the Owner that it has no unresolved finding for recovery against it issued by the Auditor of the State of Ohio on or after January 1, 2001, except as permitted by Section 9.24 (F) of the Ohio Revised Code.

V. PREVAILING WAGES

1. For "Construction" projects as defined in Section 4115.03 of the Ohio Revised Code, the successful Bidder and all of its subcontractors, regardless of tier, will strictly comply with its obligation to pay a rate of wages on the Project not less than the rate of wages fixed for this Project under Section 4115.04 of the Ohio Revised Code. Additionally, for such "Construction Projects," the successful Bidder will comply with all other provisions of Chapter 4115 of the Ohio Revised Code. Where Federal prevailing wage rates apply the successful Bidder and all of its subcontractors, regardless of tier, will strictly comply with its obligation to pay a rate of wages on the Project not less than the rate of wages fixed for this Project under the applicable Federal law. See **Appendix B**.

W. FEDERAL FUNDING

1. If the Project is subject to terms as a result of federal funding, it will be indicated in the Contract Documents.

X. OHIO PUBLIC WORKS COMMISSION FUNDING

1. For projects funded in whole or in part by the Ohio Public Works Commission, the State of *Ohio Equal Employment Opportunity Requirements and Bid Conditions for OPWC-Assisted Construction Projects* shall apply and Bidders must conform to its requirements, including but not limited to furnishing the required certifications with Bidder's bid. These requirements are included in the bid documents.

REQUEST FOR INFORMATION (PRE-BID)

The person, firm, or corporation submitting a request for information shall be responsible for its prompt delivery and do so in a manner that will allow a sufficient period of time for the issuance and delivery of an Addendum under Section N of the Information and Requirements for Bidders prior to the receipt of bids. Please submit all pre-bid questions in writing to:

City of Gahanna
Department of Public Service and Engineering
200 South Hamilton Road, Gahanna, Ohio 43230
Fax: (614) 342-4100
Attn: Robert Priestas, Director of Public Service and Engineering

Name:	Phone:
Company:	Fax:
<u>Requested Information:</u>	

APPENDIX A

SUPPLEMENTARY SPECIFICATIONS

**2019 STREET PROGRAM, ST-1064
SUPPLEMENTAL SPECIFICATIONS**

PROPOSAL - No extra compensation will be paid to the contractor by reason of compliance with any of the requirements indicated in the specifications, but payment shall be deemed to be included among the several items, as bid upon, unless otherwise specifically provided.

COMPLETION DATE – The work under this contract shall be completed in a manner acceptable to the City on or before the date listed in the notice to bidders unless an extension of time is granted in writing by the Director of Public Service.

REFERENCE SPECIFICATIONS – The requirements of the City of Gahanna, together with the “Construction and Material Specifications, City of Columbus, Ohio” including all supplements thereto in force on the date of the contract, shall govern all materials and workmanship involved in the improvements, except as such specifications are modified herein.

MAINTAINING TRAFFIC – One lane, two-way traffic shall be maintained at all times, except for Douglas Dr, Flintwood Dr, Nob Hill Ct, Lancewood Dr, Jahn Dr, Cotswold Pl, and Headley Park. All traffic control devices, including lights, signs, and barricades shall be constructed, erected, and maintained in accordance with the “Ohio Manual of Traffic Control for Construction and Maintenance”.

The cost of all lights, signs, barricades, police patrolmen, and watchmen necessary to maintain the aforementioned condition shall be included in the price bid for the various items as set forth in the proposal.

Contractor shall perform and finish ALL work relative to sidewalks before performing work in the adjacent roadway. Performing sidewalk work first provides access for the adjacent properties and their residents while the roadway is under construction.

Contractor shall not perform any work and all roads shall be open on Jahn Drive, Olde Ridenour, Morrison Rd, McCutcheon Rd, S. Hamilton Rd, N. Hamilton Rd, and N. High St during the Blues and Jazz Festival (June 14 – 16).

Jahn Dr and Douglas Dr rebuilds cannot start until the sidewalks have been completed and are available for residents to use.

Headley Park parking lot can only be closed during the month of July. Actual start date must be approved by the City of Gahanna.

ITEM 202 SIDEWALK REMOVAL – This item shall include the removal and disposal of existing sidewalks and curb ramps identified for removal in the proposal, where shown on the plans or deteriorated sidewalks marked for replacement by the Engineer. Also included under this item are any saw cuts necessary to provide a clean joint at the removal limits. Payment for this item will be made at the contract unit bid price per square foot.

ITEM 203 EXCAVATION (Douglas Dr, Flintwood Dr, Nob Hill Ct, Lancewood Dr, Jahn Dr, Cotswold Pl, And Headley Park) – This item shall include the removal of existing pavement,

expansion joints, additional subgrade, abandoned gas piping, and curbs as identified by the Engineer, and any other miscellaneous excavation necessary for the reconstruction of the roadway. Disposal of excavated materials shall be the responsibility of the Contractor.

Also included under this item shall be subgrade fine grading and compaction, and any saw cutting necessary between remaining sections and the sections to be removed. Payment for this item will be made at the contract lump sum price.

ITEM 253 FULL DEPTH PAVEMENT REPAIR – In accordance with the City of Columbus Construction and Material Specifications. This work consists of removing existing asphalt concrete, brick, PCC, or aggregate pavement courses, shaping, and compacting the exposed base material.

All repairs shall be left in a condition that is suitable to support traffic at the end of each work day, and during times of non-work periods. All repair areas shall be completed within 3 calendar days from when the work begins. "Bump" signs shall be supplied for all areas of where there is an uneven surface.

Full depth pavement repairs can be made to a minimum width of 3ft.

Also included under this item shall be the correction of any subgrade material as directed by the engineer.

Payment is full compensation for furnishing of all materials, labor, and equipment, including aerosol spray paint and replacement and restoration materials; cutting, removing, and disposing of existing pavement; shaping and compacting the underlying material, subgrade correction, placing new pavement; crack sealing all joints; and restoring the shoulders for all labor, equipment, and incidentals necessary to complete this work.

Replacement pavement sections for roadway types shall adhere to the following:

Base repair as needed, 7" 301 asphalt concrete base (placed in two lifts), and 2" asphalt concrete surface course. The binder shall be PG64-22.

This item shall include crack seal of all seams created by a full depth pavement repair.

Payment for this item will be made at the contract unit price per square yard.

ITEM 254 PLANING – In accordance with the City of Columbus Construction and Material Specifications. Prior to asphalt concrete placement, all loose material shall be removed and disposed of by the Contractor. The edges of the remaining asphalt concrete shall be painted with RS-1, or an approved equal tack coat.

Planing can be made to a minimum width of 3ft.

The procedure for **1" to 3" Planing** shall be to plane the existing asphalt surface down to the existing concrete surface with the exception of streets with Water-Bound Macadam base where a minimum of 1/2" of asphalt is to remain. Payment for this item will be made at the contract unit price per square yard.

Butt joints are to be 6' wide at a depth beginning at 2" and tapering to zero to allow for 2" of asphalt to be feathered into an existing asphalt surface. This item shall be included with the unit price bid for ITEM 254 Planing. No separate payment will be made for Butt Joints.

All planed surfaces shall be overlaid within 7 calendar days of planing completion. After the existing surface is planed, "BUMP" signs shall be provided until the surface is overlaid to provide notification of an uneven surface.

ITEM 306 7" CONCRETE BASE - Item 306 – 7" Concrete Base shall reference Item 452 – Non-Reinforced Portland Cement Concrete Pavement. The concrete proportioning shall meet the requirements of Item 499, Concrete, Class C.

ITEM 410 TRAFFIC COMPACTED SURFACE – This item has been included for use in aiding ingress/egress during the construction activities, Traffic Maintenance, and to achieve proper subgrade densities, as approved by the engineer. Payment for this item will be made at the contract unit price per cubic yard.

ITEM 423 CRACK SEAL – Type I, in accordance with the City of Columbus Construction and Material Specifications. Payment will be made at the contract unit price per square yard.

ITEM 448 ASPHALT CONCRETE – During the installation of the 448 intermediate and surface asphalt courses, the Contractor must be able to obtain compaction test results that are a minimum of 96% of the Maximum Theoretical Density. Prior to the start of production, the asphalt supplier shall submit the JMF (Job Mix Formula) proposed for each mix, including the Maximum Theoretical Density values.

During construction, the contractor shall utilize nuclear gages to continually test the density of the asphalt as it is being installed to ensure that the compaction of the asphalt falls within these ranges. The Contractor shall be responsible for ensuring that proper rolling equipment is utilized to produce the densities specified. In the event the equipment is not capable of producing the densities specified, the placed material shall be removed and replaced at the Contractor's expense. These requirements are in addition to the other requirements contained within the Columbus Construction Materials Specifications.

All pavement seams and joints shall be crack sealed.

Payment for 448 intermediate and surface courses shall be made at the contract unit bid price per cubic yard according to thickness as specified in the proposal.

Patching is intended to allow for 1-1/2" of asphalt to be placed on top of the milled surface to ensure the transition from the curb ramp to the pavement is compliant, as defined by the Engineer. Payment for this item will be made at the contract unit price per square yard.

ITEM 608 CONCRETE WALK – This work shall include the construction of new sidewalks to the lines, grades, and cross sections to meet the requirements of ADA compliant curb ramps identified in the proposal, where shown on the plans or deteriorated sidewalks marked for replacement by the Engineer. Concrete walks shall be 4" in thickness and increased to 6" in thickness for residential driveway aprons, and 8" for commercial driveway aprons.

Sidewalks shall be constructed with a 3/16" per foot (1.56%) cross slope. The sidewalk construction on Jahn Drive and Douglas Drive is to be a 5' wide walk with a 4' green area between the curb and sidewalk. The sidewalk is to be installed in such a manner as to meet the existing drives, in an effort to minimize changes to existing driveways. This item shall include all excavation, removal of existing sidewalk and curb ramps as directed by the project plans or engineer including backfill, topsoil, seeding, and disposal of surplus excavation.

Included under this item shall be the adjustment, to grade, of any valve boxes, manholes, or misc. appurtenances encountered during sidewalk construction. The contractor shall furnish and install expansion material around all existing appurtenances and sidewalks as required by the Engineer. Payment for this item will be made at the contract unit price per square foot.

ITEM 609 CURB RAMPS (ADA COMPLIANT RECONFIGURATION) – Curb ramps shall be constructed to the lines, grades, slopes, and cross sections required to meet ADA compliance. Curb ramps shall conform to the City of Columbus Standard Drawings 2319 DR. A, except as modified herein. All ramps shall have Type E detectable warnings (Armor Tile panels or approved equal) in accordance with City of Columbus Supplemental Specification 1551.01, 1551.02, 1551.03, and 1551.04. The cost of the detectable warnings shall be included in the bid price of the ramp. Completed curb ramps not meeting ADA dimensions and slope requirements shall be reconstructed at the Contractor's expense.

Also included under this item shall be the removal and replacement of any stop signs, street name signs, 80 SF of sidewalk, and 12 LF of curb and gutter necessary due to the reconfiguration of the curb ramps for ADA compliance.

This item shall include all excavation, removal of existing sidewalk, curb ramps, and curb and gutter as directed by the project plans or engineer, backfill, topsoil, hydro-seeding, and disposal of surplus excavation.

Payment for this item shall be made at the unit bid price per ramp. This includes the ramp, detectable warnings, flared sides, curb, all sidewalk, excavation, restoration and rolled edges.

ITEM 609 CURB RAMPS (TRUNCATED DOME REPLACEMENT) – Curb ramps shall be constructed to the lines, grades, slopes, and cross sections required to meet ADA compliance. Curb ramps shall conform to the City of Columbus Standard Drawings 2319 DR. A, except as modified herein. All ramps shall have Type E detectable warnings (Armor Tile panels or approved equal) in accordance with City of Columbus Supplemental Specification 1551.01, 1551.02, 1551.03, and 1551.04. The cost of the detectable warnings shall be included in the bid price of the ramp. Completed curb ramps not meeting ADA dimensions and slope requirements shall be reconstructed at the Contractor's expense.

This item shall include all excavation and removal of curb ramp truncated domes as directed by the project plans or engineer, backfill, topsoil, hydro-seeding, and disposal of surplus excavation.

Payment for this item shall be made at the unit bid price per ramp. This includes the truncated dome, and all appurtenances required for the replacement, which shall include but not be limited to flared sides, ramp removal and replacement, excavation, restoration, and rolled edges.

ITEM 609 CURB REPLACEMENT – This work shall include the removal and the replacement of combination curb and gutter necessary for the construction of compliant curb ramps or replacement of deteriorated combination curb and gutter sections as identified and marked by the Engineer. Sections of curb to be replaced are to be a minimum length of 4 feet.

Combination curb and gutter shall be installed to the original lines, grades, and cross sections, or when near curb ramps, to the lines, grades, and cross sections required to meet ADA requirements for compliant curb ramps or as directed by the Engineer. All existing curb stamps shall be reinstalled in replacement curb sections.

This item shall include all excavation, backfill, topsoil, hydro-seeding, and disposal of surplus excavation and removed curb and gutter, furnishing and installing joint materials, restoration of private utilities including irrigation and invisible dog fences and any asphalt patching.

The joint separating the gutter from the street is required to be saw cut in areas where the concrete extends into the area to be paved. The cost of this work is to be included in this item. Also included in this item are any saw cuts necessary to provide a neat joint at the removal limits, as marked by the Engineer. Roof drain openings shall be provided through the curbs for all existing drain lines. The cost for providing these openings, and extending all existing drain lines through these openings, shall be included in this item.

Payment for this item will be made at the contract unit price per lineal foot of curb replaced.

ITEM 614 MAINTAINING TRAFFIC – All traffic control devices, including lights, signs, and barricades shall be constructed, erected, and maintained in accordance with the "Ohio Manual of Traffic Control for Construction and Maintenance".

The cost of all lights, signs, barricades, police patrolmen and watchmen necessary to maintain the aforementioned condition shall be included in the price bid for this item.

Douglas Dr, Flintwood Dr, Nob Hill Ct, Lancewood Dr, Jahn Dr, Cotswold Pl, and Headley Park, can be closed to traffic as required for removal and reconstruction of the road. The next section of a rebuild cannot start until driveway access is permitted for the previous sections.

Once the road/parking lot is closed, the construction of the new road shall be continuous so that the roadway can be opened as soon as possible to residents. Closure time shall be kept to a minimum and no longer than 16 calendar days per phase. Any exception shall be subject to approval in advance by the City Engineer. Property owners affected by the road closure are to be given 72 hours written notice before closing the road. To minimize disruption to the residents, the contractor is to provide a minimum of (4) golf carts per section of rebuild for the entire duration of the road closure; additional golf carts may be required by the City Engineer.

Performance of work requiring road closures cannot occur prior to May 29th. Performance of minor work such as curb replacement, curb ramps, sidewalks, etc. may occur prior to May 24.

Work cannot be performed on the following streets at the same time: Douglas Dr and Jahn Dr as well as Nob Hill S to the court and Nob Hill S to Nob Hill W.

Jahn Dr and Douglas Dr rebuilds cannot start until the sidewalks have been completed and are available for residents to use.

Headley Park parking lot can only be closed during the month of July. Actual start date must be approved by the City of Gahanna. Reclamite and striping dates are to be approved by the City of Gahanna. All work to be completed by August 16th.

Work cannot be performed on Jahn Drive, Olde Ridenour, Morrison Rd, McCutcheon Rd, S. Hamilton Rd, N. Hamilton Rd, and N. High St during the Blues and Jazz Festival (June 14 – 16).

Striping work cannot be performed during the Blues and Jazz Festival (June 14 – 16), Independence Day (date to be determined), or Vettes, Rod and Classics Car Show (date to be determined).

The contractor shall notify the local Fire Department and the Gahanna Police Department prior to said closings and shall make provisions for access to the roadway should an emergency require access by either the fire or police department. A quantity of **Item 410 Traffic Compacted Surface** has been included for use in providing and maintaining traffic. The use of this item shall be subject to approval by the City Engineer.

After placement of the concrete/roller compacted concrete base, the road shall be opened within 24 hours. In addition, once the concrete/roller compacted concrete base has been placed the intermediate and surface courses for Douglas Dr, Flintwood Dr, Nob Hill Ct, Lancewood Dr, Jahn Dr, Cotswold Pl, and Headley Park shall be completed within 7 calendar days.

ITEM 623 CONSTRUCTION LAYOUT STAKES – The Contractor shall provide all staking required to reconstruct Douglas Dr, Flintwood Dr, Nob Hill Ct, Lancewood Dr, Jahn Dr, Cotswold Pl, and Headley Park on present alignment and profile in accordance with the supplied sections within the Appendix. All staking shall be completed under the field supervision of a Registered Professional Surveyor. A baseline shall be established at 25-foot stations along each side of the existing curbs to establish horizontal alignment. Elevations of existing profile grade shall be obtained at the 25-foot stations and at curb inlets so that the road can be replaced on present alignment and profile. The existing and proposed grades shall be submitted to the Engineer 2 week prior to the start of construction for approval. Payment for this work shall be made at the contract lump sum price.

ITEM 653 & 659 TOPSOIL, SEEDING, AND MULCHING – The Contractor shall provide suitable topsoil material in accordance with Item 653 at a nominal depth of 4" to properly fill all voids and level uneven ground left by construction activities. These areas shall be hydro-seeded and mulched in accordance with Item 659. Repair seeding and mulching is included under this item and shall take place in the fall following the completion of construction and in the spring of the following year. Payment for this item will be made at the contract lump sum price for each project.

REMOVE/REPLACE BASE OF DRIVES – This item includes the removal, all saw cuts required to remove, disposal, and the replacement of the lower portion of each driveway approach or concrete pad adjacent to the existing curb within the roadway reconstruction limits. Limits of removal shall extend from the back of curb to the sidewalk. The drive shall be concrete 6" in thickness for residential driveways and 8" for commercial driveways from curb to walk, maintain the existing drive

depth and material for any removal behind the walk with a minimum depth of 6". Any additional driveway that is to be removed and replaced to create an acceptable slope (15% max slope) specified by the engineer shall be included under this item. Payment for this item will be made at the contract unit price per square yard of concrete drive replaced.

RESTORATION AND CLEANUP – It is the intent of the City to keep inconvenience to the property owners to an absolute minimum. All work prescribed and described in these specifications is situated in improved areas. Any street signs or landscaping features removed during construction by the Contractor must be restored by the Contractor in a timely manner. The cost for removing and replacing signs, mailboxes and landscaping features shall be included in the price bid for the various items as set forth in the proposal. All work is to continue on a uniform basis and on schedule, particularly the restoration and cleanup of disturbed areas after construction. Disturbed areas such as sidewalks and curb ramps must be clearly marked by the contractor until the work can be completed. Restoration of disturbed areas shall to include the entire tree lawn. **All disturbed areas shall be restored within 2 weeks after completion of construction.** The City will pay only for those items that are completed in their entirety as described in the specifications.

TREE AND STUMP REMOVAL – The item includes tree removal, grinding of stumps and surface roots to a minimum depth of 6 inches below ground level. The contractor is responsible for the disposal of all trimmings, cuttings, and chippings. Payment for this work shall be made at the contract lump sum price.

MCCUTCHEON AND STYGLER TRAFFIC SIGNAL IMPROVEMENTS – The item includes the installation and/or replacement of all signal wiring, signal heads, installation of a tether, installation of the Autoscope Vision Detection cameras and all programing, materials, and supplies to complete this item. The signal heads shall be yellow and green polycarbonate with cutaway visors, LED, span wire mounting hardware with balance adjuster/tri-stud, alternating louvered backplates and 2" reflective tape per ODOT specs. The autoscope vision cameras and mounting hardware shall be powder coated Gahanna Green or approved equal.

The new signal heads, wiring, tether, and detection cameras shall be installed in a manner that the existing signal can remain operational until the final connection must be made. The signal is only permitted to be turned off for 1 day between 9am and 3pm and 9pm to 7am. The date of the final connetion must be approved by the City of Gahanna.

All traffic control devices, including lights, signs, and barricades shall be constructed, erected, and maintained in accordance with the "Ohio Manual of Traffic Control for Construction and Maintenance".

The cost of all lights, signs, barricades, police patrolmen and watchmen necessary to maintain the aforementioned condition shall be included in the price bid for this item.

This item shall be completed prior to the resurfacing of McCutcheon Rd.

Payment for this item will be made at the contract lump sum price.

CITY OF COLUMBUS
PUBLIC SERVICE DEPARTMENT
TRANSPORTATION DIVISION
SUPPLEMENTAL SPECIFICATION 1503
SOIL STABILIZATION

JULY 8, 2002

- 1503.01 Description
- 1503.02 Materials
- 1503.03 Laboratory Mixture Design
- 1503.04 Equipment
- 1503.05 Storage and Handling
- 1503.06 Construction Methods
- 1503.07 Curing and Protection
- 1503.08 Maintenance/Defective Areas
- 1503.09 Basis of Payment

SOIL STABILIZATION

1503.01 Description. This supplemental specification outlines the requirements for constructing a stabilized soil structure by uniformly mixing an approved chemical stabilizer, such as Lime, Quicklime, Fly-Ash and/or Cement with the soil and compacting the resulting mixture.

The intended purpose is to permanently strengthen and weather-proof the subgrade soil. Credit may be accorded for this process in pavement design, if all parameters of this specification are complied with.

1503.02 Materials. The materials used shall meet the following requirements:

Lime. Hydrated lime and Quicklime shall meet the requirements of section 712.04 (b) of the CMSC.

Cement. Cement shall meet the requirements of section 701 of the City of Columbus Construction and Material Specifications.

Fly Ash. Fly Ash, Class C or F, shall meet the requirements of section 705.13 and ASTM C 618. Fly Ash not conforming to these requirements may be considered, provided performance requirements of this specification can be proven.

Water. Water shall be clean and clear. If the water is of questionable quality, it shall be tested in accordance with the requirements of AASHTO T 26.

Other Materials. It is not the intent of this document to limit the use of other materials, however, it is beyond the scope of this document to focus on materials for which AASHTO and ASTM standards have not been developed. Materials not conforming to the above, may be considered, provided performance requirements of this specification can be proven.

1503.03 Laboratory Mixture Design. Proposed mix design proportions and recommended depth of application shall be submitted to the City by an approved geotechnical firm, selected by the Contractor, sufficiently in advance of the work for review and approval. If pavement design options are to be considered, submittals must be received no less than 45 days in advance of stabilization operations. A sufficient number of samples shall be taken to insure control data, {moisture-density relationship curve(s)}, developed in the laboratory, represents field conditions,

and to account for any changes in soil type. A mix design shall be submitted for each anticipated soil type.

The proposed mix design shall yield a minimum CBR value of 20 and a minimum average unconfined compressive strength of at least 100 psi at 7 days, and at least 150 psi at 28 days.

1503.04 Equipment. The Contractor shall use equipment that will produce results meeting the requirements for application of materials, compaction, and finishing as

controlled by these Specifications. Mixing shall be performed using an approved power driven rotary type mixer. Prior to construction, all equipment shall be in satisfactory working condition, and available for inspection by the Project Engineer or his designee.

1503.05 Storage and Handling. Admixtures shall be properly stored and handled in closed weatherproof containers until immediately before distribution. Hydrated lime, Quicklime, or Cement in bags shall be properly stored in weather-protected conditions with adequate protection from ground dampness. The storage facilities shall be approved by the City.

1503.06 Construction Methods.

Temperature and Weather Limitations. Stabilization shall be performed only when ambient air temperature is above 40° F, and when the soil is not frozen. Do not perform this work during wet or unsuitable weather, or when freezing weather is anticipated within 24 hours of mixing/compaction.

Preparation of Existing Roadway. Prior to starting the stabilization process all unsuitable materials, such as stumps, roots, and organic material shall be removed. Construct the area to be stabilized to an elevation such that, upon completion of the operations, the subgrade will conform to the lines, grades, and cross-section shown on the plans.

Spreading of Material. The admixture shall be spread using equipment that will provide uniform distribution over the entire repaired area and in such a manner as to limit scattering and loss by wind.

Tailgate spreading of material will not be permitted.

The material may be spread in either a slurry or dry form at the option of the Contractor.

Mixing. Mixing operations shall be such that all ingredients are distributed evenly throughout the required depth, and provide a uniform mixture, free of segregation, that is satisfactory to the Engineer. The moisture content of the mixture shall be maintained at $\pm 2\%$ of the optimum moisture content.

The material shall be pulverized so that 100% passes the 1 inch sieve and 60% passes the #4 sieve.

Compaction. Immediately upon completion of the spreading/mixing operations, the mixture shall be thoroughly compacted to 98% of the maximum dry density established during the preparation of the laboratory mix design. All soil subgrade shall be compacted to 100%. The number, type, and weight of rollers shall be sufficient to compact the mixture to the required density.

If depressions, defective areas or soft spots develop during the compaction operation, they shall be corrected immediately.

After each section is completed, field density tests shall be made in accordance with

COC Supplemental Specification 1501. If the compacted mixture fails to meet the specified density requirements, further evaluation by means of a test roll per section 204.07, may be performed at the discretion of the Project Engineer to evaluate subgrade stability for acceptance. The City may require the area to be reworked as necessary to meet these requirements and may require the Contractor to change compaction equipment and/or methods to obtain the required density.

Finishing. When compaction of the stabilized soil is nearing completion, the surface shall be shaped to the required lines, grades and cross section within the tolerances of item 203.08. Compaction should continue until the required density is obtained.

1503.07 Curing and Protection. After the subgrade has been finished as specified, it shall be cured for a period of at least 5 days above 40°F, or until core samples extracted from the subgrade meet the requirements of 1503.03.

During the curing period, the subgrade shall be protected against drying by applying an approved prime coat or polymer solution to prevent moisture loss.

All traffic or equipment other than curing equipment shall not be allowed on the finished subgrade until completion of curing, unless permitted by the Engineer.

1503.08 Maintenance/Defective Areas. The contractor shall maintain, at his expense the entire stabilized area in a manner satisfactory to the City. Maintenance shall include immediate repairs of any defective or damaged portions of the treated subgrade.

1503.09 Basis of Payment. The accepted quantities of stabilized soil will be paid for at the contract unit price per square yard or cubic yard, (*square meter or cubic meter*), which price and payment shall be full compensation for furnishing and placing all materials.

Item	Unit	Description
1503	Square Yard	Soil Stabilization

CITY OF COLUMBUS
PUBLIC SERVICE DEPARTMENT
TRANSPORTATION DIVISION

SUPPLEMENTAL SPECIFICATION 1551 (*Modified for City of Gahanna*)
DETECTABLE WARNINGS

March 1, 2004

- 1551.01 Description
- 1551.02 Materials
- 1551.03 Dimensions
- 1551.04 Application
- ~~1551.05 Method of Measurement (see page 52)~~
- ~~1551.06 Basis of Payment (see page 52)~~

1551.01 Description.

This work shall consist of furnishing all material, equipment, and labor necessary for the placement of detectable warning devices at curb ramps or other walking surfaces, complete and ready for service at locations shown on the plans. All work shall be in accordance with City of Columbus Standard Drawing 2319 Dr. A and with Section 1108 of the Architectural and Transportation Barriers Compliance Board's "Draft Guidelines For Accessible Public Rights-of-Way", dated June 17, 2002 as amended, supplemented and adopted.

1551.02 Materials.

All products shall receive prior approval by the City Engineer and be included in the City of Columbus, Transportation Division current listing of approved Producers and Products for detectable warning surfaces. New Products shall be submitted for review and approval in accordance with the City's General Policy and Procedures for New Products, Materials, and Construction Procedures.

Detectable warning surfaces shall be textured to provide slip resistance and shall contrast visually with adjacent walking surfaces – either light-on-dark, or dark-on-light. The preferred color for a light background shall be brick red. The preferred color for a dark background shall be safety yellow or light granite. Other colors may be specified or approved by the City Engineer provided that samples are submitted to and approved by the City Engineer at least three (3) working days prior to installation. Color submittals shall include manufacturer's statement of percentage of visual contrast provided according to ADAAG A4.29.2. Color shall be

integral with the detectable warning device and shall not be surface applied. Paints or other surface coatings shall not be used.

Detectable warning surfaces shall be classified by type of material and/or application method:

**Type "A" – Pre-Cast, Manufactured Clay and Concrete Pavers -
Approved for new construction, only.**

Type "B" – Surface-Applied or Surface-Formed Domes – Generally includes truncated domes bonded to the surface of existing curb ramps - **Approved for retrofit, only.**

Type "C" – Stamped, Color Dyed Concrete - **Approved for new construction, only.**

Type "D" – Surface-Mounted, Thin Tile and Thin Molded Sheet Goods – Generally includes tiles or mats (rigid & flexible, with preformed truncated domes), bonded and/or anchored to the surface of existing curb ramps - **Approved for retrofit, only.**

Type "E" – Pre-Manufactured, Wet-Set Products – Generally includes rigid products pressed into freshly formed concrete - **Approved for new construction, only.**

1551.03 Dimensions.

Truncated domes in a detectable warning surface shall have a base diameter of 0.9 inches (23 mm) minimum to 1.4 inches (36 mm) maximum, a top diameter of 50% of the base diameter minimum to 65% of the base diameter maximum, and a height of 0.2 inches (5 mm).

Truncated domes in a detectable warning surface shall have a center-to-center spacing of 1.6 inches (41 mm) minimum and 2.4 inches (61 mm) maximum, and a base-to-base spacing of 0.65 inches (16 mm) minimum, measured between the most adjacent domes on a square grid.

Detectable warning surfaces shall extend 24 inches (610 mm) minimum in the direction of travel and the full width of the curb ramp, landing, or blended transition.

Pavers shall be laid so that the centers of domes align with a straightedge placed both perpendicular and parallel with the direction of travel. Dome Alignment may not differ by more than 1/4-inch.

The detectable warning surface shall be located so that the edge nearest the curb line is 6 inches (150 mm) minimum and 8 inches (205 mm) maximum from the face of the curb line.

Domes shall be aligned on a square grid, aligned in rows parallel and perpendicular to the predominant direction of travel. Domes must be not be skewed diagonally to the direction of travel.

1551.04 Application.

Detectable warning devices shall be installed in accordance with manufacturer's specifications, except as modified by this specification or as otherwise specified on the plans. The finished surface shall be uniformly profiled to match the adjoining surfaces without lips, obstructions and shall drain completely.

The contractor shall warrant the installed surface to last no less

than five years without losing more than two percent of the truncated domes due to delaminating as a result of product failure, and shall further warrant the surface for a minimum of five years against fading, chipping, peeling, cracking, or loss of original shade due to sunlight, salt or exposure to weathering.

Special Application Notes: Type "A" – Pre-Cast, Manufactured Clay and Concrete Pavers:

- Pavers shall be laid on an unreinforced concrete base. Thickness of the base shall be the greater of 4-inches or the specified, nominal thickness of the curb ramp.
- Pavers shall be set into a 1/2-inch thick bed of freshly poured latex or epoxy -modified cement mortar.
- Pavers (exclusive of domes) shall be flush with the surrounding concrete. The surface shall not differ by more than 1/8-inch in height.
- Pavers shall be laid so that the centers of domes align with a straightedge placed both perpendicular and parallel with the direction of travel. Dome Alignment may not differ by more than 1/4-inch.
- Joints between pavers and surrounding concrete surface shall be mortared and shall not exceed 1/4-inch in width. Mortared joints shall be flush with top surface and struck so as to give a smooth surface.
- Joint spacing between pavers shall be no greater than 5/32-inch and not less than 1/16-inch. Pavers shall not be directly touching each other unless they have spacing bars
- Joints between pavers shall be sand-filled. Sand shall be washed, non-plastic, well-graded angular material free from deleterious or foreign matter, with maximum particle size not larger than the specified joint spacing. Gradation shall conform to Item 703.02 fine aggregate for concrete. Sweep this material to fill the joints and water with a fine mist. Repeat as necessary to achieve a sand-filled joint. When requested by the Engineer, the Contractor shall submit gradation analysis of the proposed joint material performed in accordance with ASTM C-136.
- Pavers shall consist of full, completely formed domes and shall be crack-free.
- The face of all pavers shall be clean of cement and protected so as to avoid chipping during construction.
- A minimum of 6-inch horizontal edge restraint shall be provided around the full perimeter of the detectable warning pavers. The restraints shall consist of Class "C" cast in place concrete, (City of Columbus CMS item 499).

**CITY OF COLUMBUS
PUBLIC SERVICE DEPARTMENT
TRANSPORTATION DIVISION
SUPPLEMENTAL SPECIFICATION 1523
ROLLER COMPACTED CONCRETE PAVEMENTS (RCC)
APRIL 15, 2006**

- 1523.01 Description**
- 1523.02 Materials Requirements**
- 1523.03 Mix Design**
- 1523.04 Equipment**
- 1523.05 Placing RCC**
- 1523.06 Compaction and Finishing**
- 1523.07 Small Areas**
- 1523.08 Joints**
- 1523.09 Curing**
- 1523.10 Tolerances**
- 1523.11 Quality Assurance and Control**
- 1523.12 Defective RCC**
- 1523.13 Asphalt Surfacing / Opening to Traffic**
- 1523.14 Warranty**
- 1523.15 Basis of Payment**

**ROLLER COMPACTED CONCRETE PAVEMENTS
(RCC)**

1523.01 Description

This Supplement outlines the requirements for production and construction of Roller Compacted Concrete (R.C.C.) pavement for City streets. In addition to this supplement, items 305, 306, 401, 407, 451, and 700 of the City of Columbus Construction and Material Specifications (CMSC) apply where applicable.

1523.02 Materials Requirements

All materials to be used shall be from approved sources as documented on the "Approved Materials List" on file in the City's testing laboratory.

Cement: Portland Cement shall conform to the standard specification for Portland Cement Type I, ASTM C 150 (latest edition).

Fly Ash: Fly Ash shall conform to ASTM C 618 Class F and section 705.13 of the CMSC.

Aggregates: Fine and course aggregates shall meet the requirements of section 703.02 of the CMSC for Portland Cement Concrete, item 305 and 306. The aggregates shall be well graded to conform to the following composite gradation.

<u>Sieve Size</u>	<u>Percent Passing</u>
1"	100
3/4"	90 – 100
1/2"	70 – 90
3/8"	60 - 85
#4	40 – 70
#16	20 – 40

#100	5 – 20
#200	2 - 8

Water: Clean, potable and free from oil, acid, and strong alkalies or organic materials.

Admixtures (other than fly ash): Meet applicable ASTM standards.

1523.03 Mix Design

The Contractor/Supplier shall develop an R.C.C. mixture proportioned in accordance with this specification and procedures discussed in ACI 325.10R-95 "State-of-the-Art Report on Roller-Compacted Concrete Pavements" sections 4.2 and 4.3. Once the mix has been designed, certified test data shall be submitted in accordance with Section 101.10 of the CMSC from a recognized testing laboratory that shows the proposed mix design will meet the following requirements.

Compressive Strength, Cylinders: 3500 psi @ 28 days
Flexural Strength, Beams: 500 psi @ 14 days
Splitting Tensile Strength, Cores: 400 psi @ 14 days

The minimum Cementitious Material shall be 350 pounds per C.Y.

Fly Ash may only be used between April 1 and November 1 unless otherwise authorized by the Project Engineer.

1523.04 Equipment

Mixing Plants: Mixing plants shall be of a design that can produce an R.C.C. pavement mixture of the proportions defined in the approved mix design and within the specified tolerances in ASTM C 94 and ASTM C 685. The mixing plant may be a Central-Mix Drum or a Stationary Continuous-Mixing Twin-Shaft Pugmill mixer. The plant shall have a minimum manufacturer's rated capacity of 200 tons per hour.

Paver: RCC shall be placed with a high-density or conventional asphalt type paver subject to approval by the Engineer. The paver shall be capable of placing RCC to a minimum of 85% of the maximum wet density in accordance with ASTM D 1557 or equivalent test method. The paver shall be of suitable weight and stability to spread and finish the RCC material, without segregation, to the required thickness, smoothness, surface texture, cross-section and grade.

Alternative Paving Equipment. In areas not accessible to paving machines, alternative paving equipment including graders and dozers may be used, if approved by the Engineer. The equipment shall be capable of producing a finished product that results in a smooth, continuous surface without segregation, excessive tearing, or rock pockets. Work in areas inaccessible to paving machines will be performed according to 1523.07 of these specifications.

Pneumatic Rollers: Pneumatic rollers shall be self-propelled, with overlapping tire positions capable of providing full compaction in a single pass. Static weight shall be no less than 10 tons, or more than 20 tons. Tire configuration shall be 5 front and 6 rear.

Vibratory Rollers: Vibratory rollers shall be self-propelled, double drum, steel wheel vibratory rollers having a static weight of at least 10 tons. Each roller drum shall be equipped with a properly operating scraper and brush. The rollers shall transmit a dynamic impact to the surface through smooth steel drums by means of revolving weights, eccentric shafts or other equivalent methods. The roller drum shall be between 4 and 5-1/2 foot in diameter and 5-1/2 to 8 feet in width.

Finish Rollers: Finish rollers shall be self-propelled, double drum, steel wheel rollers having a static weight of between 3 and 10 tons. Each drum shall be equipped with a properly operating scraper and brush. A single drum vibrator roller with a vulcanized rubber coating may be utilized for finish rolling, at the approval of the engineer.

Equipment for Vertical Cuts in R.C.C. Pavement: To cut vertical joints in fresh R.C.C. pavement, equipment such as a wheel cutter or other approved equipment capable of cutting vertically, the full depth of the layer, shall be used. If the Contractor waits until the R.C.C. hardens to make vertical cuts, concrete sawing equipment shall be used to make the vertical cuts.

1523.05 Placing RCC

Cold Weather Limitations: R.C.C. shall not be placed on any surface containing frost or frozen material. R.C.C. shall only be placed when the ambient temperature is a minimum of 35°F and rising, unless the procedures set forth in section 451.061 "Depositing and Curing Concrete During Cold Weather", of the Construction and Material Specifications, are strictly adhered to. Conformance will be closely monitored and stringently enforced.

Hot Weather Precautions: During periods of hot weather or windy conditions, special precautions shall be taken to minimize moisture loss due to evaporation. Precautions may include cooling of aggregate stockpiles by the use of a water spray, protective covers on dump trucks, temporary windbreaks to reduce wind velocity, cooling of concrete mix water, decreasing the allowable time between mixing and final compaction, and keeping the surface of the newly placed R.C.C. pavement damp with a light spray during compaction and finishing operations.

Rain Limitations: No placement of R.C.C. pavement shall be done while it is raining hard enough to be detrimental to the finished product. Placement may continue during light rain or mist provided the surface of the R.C.C. pavement is not eroded or washed. Dump truck covers must be used during these periods. The Engineer will be the sole judge as to when placement must be stopped due to rain.

Subgrade Preparation: Prepare the subgrade according to Section 204 of the CMSC. If required, construct a granular base according to Section 304.

Moisten the surface of the subgrade or base without creating mud or ponding water, to minimize absorption of water from R.C.C. mix to be deposited.

Transporting: Transport the R.C.C. mixture to the site in dump trucks with boxes cleaned out before loading and provided with protective covers properly secured in place until discharge. The trucks shall dump directly into the hopper of the paver unless placement is by hand as directed by the Engineer. Hauling over the freshly placed R.C.C. will not be permitted.

Continuity: Co-ordinate R.C.C. delivery so the mix can be spread and rolled within the specified time limit and to ensure uniform progress of the paver until the paving operation is complete. The time between mixing, and compacting shall not exceed ninety (90)minutes, for all RCC placed, provided that the temperature of the RCC does not exceed 90 degrees (F). This time limit may be increased or decreased by the Engineer dependent upon ambient conditions of temperature and humidity.

Spreading: Spread the material to a sufficient depth that will produce the specified thickness when compacted and conform to the required cross-sections and grade. Operate the paver in a manner that will prevent segregation and will produce a smooth continuous surface without tearing, pulling or shoving. Placing of the R.C.C. mix shall be done in a pattern so that the water from previously placed R.C.C. will not affect the fresh surface or subgrade. Where required, broadcasting or fanning of R.C.C. must be performed immediately behind the paver. Any R.C.C. surface that has been compacted "rolled" but is not cured, must be scarified at least one inch

deep prior to broadcasting fresh R.C.C. over the top. Broadcasting must be completed in the allotted time within these specifications.

Segregation: If segregation occurs, suspend the paving operation until the cause is determined and corrected. Rake off segregated coarse aggregate before rolling. Broadcasting or fanning of R.C.C. mixture onto areas being compacted is not permitted.

Placing Adjacent Lanes: All R.C.C. on both sides of the longitudinal joint formed by placing an adjacent lane, must be compacted within 90 minutes of plant mixing, unless a cold joint is provided.

1523.06 Compaction and Finishing

Required Density: The Contractor is responsible for achieving 98% of the maximum wet density, as determined in the laboratory according to ASTM D 1557.

Start of Rolling: Begin compaction operations within fifteen (15) minutes after spreading of the R.C.C. mix. Any additional delay will result in the coring of the affected area at the Contractors expense to ensure that it meets the requirements of this specification.

Rolling Pattern: Establish a rolling pattern that will achieve the required density with a minimum number of roller passes.

Vibratory Rolling: During vibratory compaction, the roller shall not be started, stopped, or left standing in vibratory mode. Stagger the stopping point of successive rolling passes to avoid forming depressions on the surface.

Surface Check: Continually check the R.C.C. surface while still plastic to ensure surface and grade tolerances are met. Immediately correct excessive variations in accordance with the spreading requirements.

Finish Rolling: Remove any roller marks on the surface using a steel drum roller in static mode.

Lane Edge: Each edge of each lane shall be constructed with a vertical or a 15-degree from vertical configuration.

1523.07 Small Areas

Spread RCC mix by hand in areas not accessible by the paver, as directed by the Engineer.

Compact the mix to the required density using suitable walk-behind vibratory compaction equipment. The vibratory equipment must have a minimum centrifugal force of 2,200 pounds and/or 70 pounds per square inch. Compaction of these areas must be performed immediately after placement of the R.C.C. in order to avoid moisture loss.

1523.08 Joints

Fresh Joint: A fresh joint is made when R.C.C. on both sides of the joint are compacted within 90 minutes of plant mixing. Ensure that the contact face is moist and not segregated. Before rolling, hand-finish the joint as necessary to produce a tight surface. Roll extra passes as necessary to achieve the required density and smoothness in the joint area.

Cold Joint: A cold joint is made when either side of the joint is not compacted within 90 minutes of plant mixing. Sawcut the edge of previous lane back to sound R.C.C. to form a vertical

face. Trimming by grader blade may be permitted if done at the end of the workday or the first thing the following day. Place fresh grout on the vertical face just before placing fresh R.C.C. against it. Before rolling, hand-finish the joint as necessary to produce a tight surface. Roll extra passes as necessary to achieve the required density and smoothness in the joint area. Every effort shall be made to maintain longitudinal joints as a fresh joint as described in "Fresh Joint" above.

Transverse Joint: May be a Fresh Joint or Cold Joint as described above. They shall be spaced at a maximum of 30 foot intervals, or at intervals directed by the Engineer and cut to a depth 1/3 of the specified pavement thickness.

Longitudinal Joint: Leave the outer 12 to 18 in. of the paving lane uncompacted during the initial rolling operation. This uncompacted edge is then used to set the height of the paver screed for paving the adjacent lane. After the adjacent lane is placed, the joint is compacted by centering the roller drum over the joint and compacting the adjacent lane edges simultaneously.

1523.09 Curing

R.C.C. without Asphalt Surfacing applied within 72 hours: Keep the R.C.C. surface continuously moist by water, fog spray, wet burlap, or an approved membrane-forming curing compound, or polyethylene sheeting for a period of 7 days. Apply curing compound at 1-1/2 times the rate specified by the manufacturer.

R.C.C. with Asphalt Surfacing applied within 72 hours: Immediately after final rolling, apply an asphalt emulsion per item 407 of the CMS. Apply at 1-1/2 times the rate specified by the manufacturer.

1523.10 Tolerances

R.C.C. pavement construction shall be subject to Section 451 of the CMSC.

1523.11 Quality Assurance and Control

Responsibility: Testing at the plant and the paving site is the responsibility of the Contractor or Developer and shall be performed by a private Independent Testing Laboratory approved by the City. The Contractor and Supplier shall provide safe and convenient access, acceptable to the Engineer, for the inspection and sampling of the R.C.C. and constituent materials, at both the production plant and the paving site, and shall cooperate in the inspection and sampling process at all times.

Test Strip: The contractor shall construct a test section of a thickness equal to the design thickness with at least 100 tons of R.C.C. The test strip will be used to resolve anticipated problems with equipment, mix behavior, compaction, and/or strength characteristics. The test strip shall be constructed at a location chosen by the contractor at least 30 days before the start of paving operations. The contractor shall cooperate fully with the Engineer during construction and testing of the test strip. During construction of the test section, the Contractor will establish an optimum rolling pattern and procedure for obtaining a density of not less than 98% of the maximum wet density in accordance with ASTM D 1557. In addition, the Contractor must also demonstrate the ability to achieve a smooth, hard, uniform surface free of excessive tears, ridges, spalls and loose material. After completion of the test section, beams and cores will be extracted to verify mix compliance. This will be performed by the Independent Testing Laboratory, at the expense of the Contractor. During the trial placement, the City's Testing Personnel shall calibrate their nuclear density gauges in accordance with ASTM C 1040, with a sample of the test section mix. Moisture readings of the gauge shall be calibrated using oven dry samples of the plant-

mixed R.C.C. If all aspects of the test strip have been previously satisfied, the engineer may waive this requirement on a project-by- project basis.

Pre-placement: The Contractor shall ensure quality control at the plant, by controlling materials, obtaining test samples and ensuring segregation is not occurring while loading haul trucks.

The private Testing Laboratory will develop a moisture/density relationship of the actual job materials in accordance with ASTM D 1557. Optimum moisture content, maximum dry and wet densities will be established.

Compressive Strength Testing: During the mix design development, the Independent Testing Laboratory shall produce six (6" x 12") diameter cylinders, in accordance with ASTM C 1435, to perform a 28 day compressive strength test of the material to verify mix conformance. Handling and curing shall be in accordance with ASTM C 31. The Engineer may require additional tests at different ages. Compressive strength testing shall be in accordance with ASTM C 39.

During Placement: The Contractor, in cooperation with the Independent Testing Laboratory, shall ensure that compaction and grade specifications are met and time limits are adhered to.

Field Density: The contractors Testing Laboratory shall perform density testing of the R.C.C. in accordance with ASTM C 1040, direct transmission mode, as soon as possible, but no more than 30 minutes, after completion of rolling. Only wet density shall be used for evaluation. The required density shall be a minimum of 98% of the maximum wet density. At least 5 tests shall be performed for each 250 cubic yards placed. The Contractor shall be responsible for verifying required densities are achieved by the paver.

If density tests indicate that the material does not meet the required density, the Engineer, in collaboration with the Contractor and the Independent Testing Laboratory, shall determine the source of the problem, whether mix properties, segregation, or gauge calibration. If mix properties have changed, or the concerns cannot be resolved, placement shall be suspended until the problem is corrected.

After Placement: The contractors Testing Laboratory shall core at least nine (9) 3 1/2 inch diameter cylindrical specimens from the interior of the slab for compliance verification. Length measurements of the cores and compressive strength testing shall be in accordance with ASTM C 42. The actual number of cores will be determined as defined in section 451.16 of the CMSC.

Testing will be conducted as follows:

Compressive Strength Testing: Three (3) of the cores obtained for thickness verification will be tested for compressive strength at 28 days.

Splitting Tensile Strength: Three (3) of the cores obtained for thickness verification will be tested for splitting tensile strength at 14 days.

Density Test: The three (3) core samples obtained for splitting tensile strength will also be tested for density PCF.

The remaining three cores will be held for backup testing and/or further review as necessary.

Flexural Strength Testing: At the option of the project Engineer, the Contractor/Independent Testing Laboratory shall cut at least three (3) rectangular beams from the interior of the slab, in accordance with ASTM C 42, to perform a 14 day flexural strength test of the material. Additional tests at different ages may be required by the Engineer.

1523.12 Defective RCC

Repairs: All repairs are subject to the Engineers approval. Correct deficiencies while R.C.C. is still plastic; otherwise do repairs after seven (7) days. After seven (7) days, the R.C.C. shall be removed by saw cutting full depth before removal. Replace the R.C.C. utilizing a Cast-in-Place concrete meeting the requirements of section 499; Class B or E Concrete as directed by project Engineer. The new concrete shall be doweled into the existing R.C.C. utilizing epoxy coated reinforcing bars unless the RCC option is utilized.

Remove and replace R.C.C. if determined deficient in thickness by following the procedure set forth in section 451.16 of CMSC.

Any R.C.C. pavement found to be of unacceptable thickness, or deficient in any testing done according to 1523.11, may be subject to removal and replacement by the contractor, at no cost to the City, including removal and replacement of any intermediate and surface asphalt courses.

Grind off high surface variations to a finish acceptable to the Engineer.

Filling of low areas with fresh R.C.C. is not permitted.

If asphalt surfacing is specified, low areas shall be made up with additional surfacing material without extra payment.

1523.13 Asphalt Surfacing / Opening to Traffic

The R.C.C. pavement may be asphalt surfaced as specified on the plans once the requirements of Section 1523.06 have been met and all transverse contraction joints have been constructed.

If the R.C.C. pavement is not to be asphalt surfaced immediately, all traffic shall be restricted from using the R.C.C. until seven (7) days has elapsed or all strength requirements of Section 1523.03 have been met. At any time prior to the expiration of the above mentioned seven (7) day period, the R.C.C. may be asphalt surfaced as specified on the plans and then opened to traffic.

1523.14 Warranty

Pavement constructed according to this specification shall be guaranteed by the developer/owner for a period not less than two (2) years from date of acceptance of the street by the City Engineer.

1523.15 Basis of Payment

The accepted quantities of R.C.C. pavement will be paid for at the contract unit price per square yard (*square meter*), which price and payment shall be full compensation for furnishing and placing all materials including reinforcing steel, dowels, and joint materials.

No additional payment over the unit contract bid price will be made for any pavement which has an average thickness in excess of that shown on the plans.

Payment for accepted quantities, complete in place, will be paid for at the contract price for item Supplemental Specification 1523.

<u>Item</u>	<u>Unit</u>	<u>Description</u>
1523	Square Yard	Roller Compacted Concrete

STANDARD SPECIFICATIONS
FOR
ASPHALT SURFACE PRESERVATION
WITH AN
ASPHALT REJUVENATING AGENT

2011 REC STNDRD LT DSR SJD

ASPHALT REJUVENATING AGENT

I. Scope:

This work shall consist of furnishing all labor, material, and equipment necessary to perform all operations for the application of an asphalt rejuvenating agent to asphaltic concrete surface courses. The rejuvenation of surface courses shall be by spray application of a maltene based cationic rejuvenating agent composed of petroleum oils and resins emulsified with water. All work shall be in accordance with the specifications, the applicable drawings, and subject to the terms and conditions of this contract.

II. Material Specifications:

The asphalt rejuvenating agent shall be an emulsion composed of a petroleum resin oil base uniformly emulsified with water. Each bidder must submit with his bid a certified statement from the asphalt rejuvenator manufacturer showing that the asphalt rejuvenating emulsion conforms to the required physical and chemical requirements.

SPECIFICATIONS

<u>Tests</u>	<u>Test Method</u>		<u>Requirements</u>	
	<u>ASTM</u>	<u>AASHTO Min.</u>	<u>Max.</u>	
<u>Tests on Emulsion:</u>				
Viscosity @ 25°C, SFS	D-244	T-59	15	40
Residue, % W ¹		D-244 (Mod.) T-59 (Mod)	60	65
Miscibility Test ²	D-244 (Mod.)	T-59 (Mod)	No Coagulation	
Sieve Test, %W ³	D-244 (Mod.)	T-59 (Mod)	-	0.1
Particle Charge Test	D-244	T-59	Positive	
Percent Light Transmittance ⁴	GB	GB	-	30
<u>Tests on Residue from Distillation:</u>				
Flash Point, COC, °C	D-92	T-48	196	-
Viscosity @ 60°C, cSt	D-445	-	100	200
Asphaltenes, %w	D-2006-70	-	-	1.00
Maltene Dist. Ratio		D-2006-70 -	0.3	0.6
$\frac{PC + A_1^5}{S + A_2}$				
PC/S Ratio ⁵	D-2006-70	-	0.5	-
Saturated Hydrocarbons, S ⁵	D-2006-70	-	21	28

¹ ASTM D-244 Modified Evaporation Test for percent of residue is made by heating 50 gram sample to 149 C (300 F) until foaming ceases, then cool immediately and

calculate results.

² Test procedure identical with ASTM D-244-60 except that .02 Normal Calcium Chloride solution shall be used in place of distilled water.

³ Test procedures identical with ASTM D-244-60 except that distilled water shall be used in place of two percent sodium oleate solution.

⁴ Test procedure is attached.

⁵ Chemical composition by ASTM Method D-2006-70:

PC = Polar Compounds, A₁ = First Acidaffins
A₂ = Second Acidaffins, S = Saturated Hydrocarbons

PROCEDURE FOR DETERMINING PERCENT LIGHT TRANSMITTANCE ON ASPHALT REJUVENATING AGENT

A. SCOPE

This procedure covers the determination of percent light transmittance of the asphalt rejuvenating agent.

B. APPARATUS

- 1) Container may be either glass, plastic or metal having a capacity of 6,000 ml.
- 2) Graduated cylinder, 1,000 ml, or greater
- 3) Light transmittance measuring apparatus, such as Bausch and Lomb or Lumetron spectrophotometer
- 4) Graduated pipette having 1 ml capacity to 0.01 ml accuracy
- 5) Suction bulb for use with pipette
- 6) Test tubes compatible with spectrophotometer, 3/4" X 6, Bausch and Lomb, Catalog No. 33-17- 81, (B&L)

C. CALIBRATION OF SPECTROPHOTOMETER

- 1) Calibrate spectrophotometer as follows: (a) Set wavelength at 580 mu, (b) Allow spectrophotometer to warm-up thirty minutes, (c) Zero percent light transmittance (%LT) scale, (d) Rinse test tube three times with tap water and fill to top of circle marking on B&L test tube or approximately 2/3 full, (e) Place tube in spectrophotometer and set %LT scale at 100, and (f) repeat steps (c) and (e) two times or until no further adjustments are necessary.

D. PROCEDURE

- 1) Shake, stir or otherwise thoroughly mix emulsion to be tested. Place sample of emulsion in beaker and allow to stand one minute.
- 2) Place 2,000 ml tap water in container.
- 3) Suck 1.00 ml emulsion into pipette using suction bulb. Wipe off outside of pipette.
- 4) Using suction bulb, blow emulsion into container.
- 5) Rinse pipette by sucking in diluted emulsion solution and blowing out.
- 6) Clean pipette with soap or solvent and water. Rinse with acetone.
- 7) Stir diluted emulsion thoroughly.
- 8) Rinse out tube to be used with the diluted emulsion three times and fill to top of circle.
- 9) Calibrate spectrophotometer.
- 10) Place diluted emulsion sample tube in spectrophotometer, cover and read %LT to nearest tenth.
- 11) Repeat steps 9 and 10 until three identical consecutive readings are achieved.
- 12) The elapsed time between addition of emulsion to dilution of water and final %LT reading should not exceed 5 minutes.

III. Material Performance: The asphalt rejuvenating agent shall have the capability to penetrate the asphalt pavement surface. The asphalt rejuvenating agent shall be absorbed and incorporated into the asphalt binder. Verification that said incorporation of the asphalt rejuvenating agent into the asphalt binder has been effected shall be by analysis of the chemical properties of said asphalt binder i.e. viscosity shall be improved to the following extent. The viscosity shall be reduced by a minimum of forty, (40%) percent as determined by dynamic shear rheometer (DSR) method for asphalt testing in accord with AASHTO T315-05. This analysis shall apply to extracted asphalt binder, taken from cores extracted fifteen to thirty days following application, in the upper 3/8" of pavement. In addition the treated areas shall be sealed in-depth to the intrusion of air and water.

The rejuvenating agent shall have a record of at least five years of satisfactory service as an asphalt rejuvenating agent and in-depth sealer. Satisfactory service shall be based on the capability of the material to decrease the viscosity of the asphalt binder and provide an in-depth seal. Reclamite[®], manufactured by D&D Emulsion, Inc., Mansfield, Ohio, is a product of know quality and accepted performance.

The bidder must submit with his bid the manufacturer's certification that the material proposed for use is in compliance with the specification requirements. The bidder must submit with his bid previous use documentation and test data conclusively demonstrating that; the rejuvenating agent has been used successfully for a period of five years by government agencies such as Cities, Counties, etc; and that the asphalt rejuvenating agent has been proven to perform, as heretofore required, through field testing by government agencies as to the required change in asphalt binder viscosity. Testing data shall be submitted indicating such

product performance on a sufficient number of projects to insure product consistency. In addition, testing data shall be submitted to indicate said product performance over a testing period of three years to insure reasonable life expectancy.

RECLAMITE®, a product of Golden Bear Oil, a division of Tricor Refining, LLC. is a product of known quality and accepted performance.

IV. Applicator Experience:

The asphalt-rejuvenating agent shall be applied by an experienced applicator of such material. The bidder shall have a minimum of three years experience in applying the product proposed for use. He must submit with his bid a list of five projects on which he applied said rejuvenator. He shall indicate the project dates, number of square yards treated in each and the name and phone number of the government official in charge of each project.

A project superintendent knowledgeable and experienced in application of the asphalt-rejuvenating agent must be in control of each day's work. The bidder shall submit a written experience outline of the project superintendent.

V. PRODUCT STANDARDS AND ALTERNATES:

The product "Reclamite"® for the asphalt rejuvenating agent as manufactured by Golden Bear oil, a division of Tricor Refining, LLC. is the standard for these specifications and the prices quoted on the Bid Sheet Base Bid shall be for this standard. Should a bidder wish to submit a bid for alternates to the Standard, said prices shall be entered on the BID SHEET as the "Alternate Bid" for each item. In the event that the bidder submits no bid for the Standard, only the "Alternate Bids" should be completed.

Bidders may offer an ALTERNATE for the Standard specified in the Specifications provided the bidder adheres to the following and submits same with his bid.

(a) List the proposed alternate on the BID SHEET form giving the product name and price.

(b) Furnish complete specifications and descriptive literature for the alternate as well as a one-gallon sample of the material proposed for use. Such descriptive and detailed information shall be complete and at least equal in detail to the agencies requirements for the standard item for which the alternate is offered.

(c) Submit a current Material Safety Data Sheet for the alternate materials. The agency will give the alternate consideration. The Contractor may furnish only those alternate items included in his proposal and approved by the agency prior to award of a contract.

(d) Furnish all required test data and use documentation as hereto for required.

If no ALTERNATE is indicated on the BID SHEET, the Contractor shall furnish the STANDARD (brand) specified in the attached specifications.

Should the ALTERNATE offered be found unacceptable by the agency based on the data submitted with the bid and no bid is entered on the BID SHEET for the Standard, then said bid will be considered non-responsive.

VI. APPLICATION TEMPERATURE/WEATHER LIMITATIONS:

The temperature of the asphalt rejuvenating emulsion, at the time of application shall be as recommended by the manufacturer. The asphalt-rejuvenating agent shall be applied only when the existing surface to be treated is thoroughly dry and when it is not threatening to rain. The asphalt-rejuvenating agent shall not be applied when the ambient temperature is below 40° F.

VII. HANDLING OF ASPHALT REJUVENATING AGENT:

Contents in tank cars or storage tanks shall be circulated at least forty-five minutes before withdrawing any material for application. When loading the distributor, the asphalt rejuvenating agent concentrate shall be loaded first and then the required amount of water shall be added. The water shall be added into the distributor with enough force to cause agitation and thorough mixing of the two materials. To prevent foaming, the discharge end of the water hose or pipe shall be kept below the surface of the material in the distributor that shall be used as a spreader. The distributor truck will be cleaned of all of its asphalt materials, and washed out to the extent that no discoloration of the emulsion may be perceptible. Cleanliness of the spreading equipment shall be subject to the approval and satisfaction of the Engineer.

VIII. RESIDENT NOTIFICATION:

The contractor shall distribute by hand, a typed notice to all residences and businesses on the street to be treated. The notice will be delivered no more than 24 hours prior to the treatment of the road. The notice will have a local phone number that residents may call to ask questions. The notice shall be of the door hanger type that secures to the door handle of each dwelling. Unsecured notices will not be allowed. The contractor shall also place the notice on the windshield of any parked cars on the street. Hand distribution of this notice will be considered incidental to the contract.

IX. APPLICATING EQUIPMENT:

The distributor for spreading the emulsion shall be self-propelled, and shall have pneumatic tires. The distributor shall be designed and equipped to distribute the asphalt rejuvenating agent uniformly on variable widths of surface at readily determined and controlled rates from 0.05 to 0.5 gallons per square yard of surface, and with an allowable variation from any specified rate not to exceed 5 percent of the specified rate.

Distributor equipment shall include full circulation spray bars, pump tachometer, volume measuring device and a hand hose attachment suitable for application of the emulsion manually to cover areas inaccessible to the distributor. The distributor shall be equipped to circulate and agitate the emulsion within the tank. The distributor shall have a computerized system, acceptable to the Engineer that controls the rate of product application.

A check of distributor equipment as well as application rate accuracy and uniformity of distribution shall be made when directed by the Engineer.

The truck used for applying slag screenings, or other aggregate approved by the Engineer, shall be equipped with a spreader that allows the slag screenings to be uniformly distributed onto the pavement. The spreader shall be able to apply 1/2 pound to 3 pounds of slag screenings per square yard in a single pass. The spreader shall be adjustable so as not to broadcast the slag screenings onto driveways or

tree lawns.

The slag screenings to be used shall be free flowing, without any leaves, dirt, stones, etc. Any wet slag screenings shall be rejected from the job site.

Any equipment that is not maintained in full working order, or is proven inadequate to obtain the results prescribed, shall be repaired or replaced at the direction of the Engineer.

X. APPLICATION OF REJUVENATING AGENT:

The asphalt-rejuvenating agent shall be applied by a distributor truck at the temperature recommended by the manufacturer and at the pressure required for the proper distribution. The emulsion shall be so applied that uniform distribution is obtained at all points of the areas to be treated. Distribution shall be commenced with a running start to insure full rate of spread over the entire area to be treated. Areas inadvertently missed shall receive additional treatment as may be required by hand sprayer application.

Application of asphalt rejuvenating agent shall be on one-half width of the pavement at a time. When the second half of the surface is treated, the distributor nozzle nearest the center of the road shall overlap the previous application by at least one-half the width of the nozzle spray. In any event the centerline construction joint of the pavement shall be treated in both application passes of the distributor truck.

Before spreading, the asphalt rejuvenating agent shall be blended with water at the rate of two (2) parts rejuvenating agent to one (1) part water, by volume or as specified by the manufacturer for jobsite conditions. The combined mixture of asphalt rejuvenating agent and water shall be spread at the rate of 0.05 to 0.10 gallons per square yard, or as approved by the Engineer following field testing.

Where more than one application is to be made, succeeding applications shall be made as soon as penetration of the preceding application has been completed and the Engineer grants approval for additional applications.

Grades or super elevations of surfaces that may cause excessive runoff, in the opinion of the Engineer, shall have the required amounts applied in two or more applications as directed.

After the rejuvenating emulsion has penetrated, a light coating of dry slag screenings, or other aggregate approved by the Engineer, shall be applied to the surface in sufficient amount to protect the traveling public as required by the Engineer. The slag screenings shall be swept and removed from the streets and properly disposed of at the Contractor's expense within 24 hours of application.

The Contractor shall furnish a quality inspection report showing the source, manufacturer, and the date shipped, for each load of asphalt rejuvenating agent. When directed by the Engineer, the Contractor shall take representative samples of material for testing.

XI. STREET SWEEPING:

The Contractor shall be responsible for sweeping and cleaning of the streets prior to, and after treatment.

Prior to treatment, the street will be cleaned of all standing water, dirt, leaves, foreign materials, etc. This work shall be accomplished by hand brooming, power blowing or other approved methods. If in the opinion of the Engineer the hand cleaning is not sufficient than a self-propelled street sweeper shall be used.

All slag screenings used during the treatment must be removed no later than 24 hours after treatment of the street. This shall be accomplished by a combination of hand and mechanical sweeping. All turnouts, cul-de-sacs, etc. must be cleaned of any material to the satisfaction of the Engineer. Street sweeping will be included in the price bid per square yard for asphalt rejuvenating agent.

If, in the opinion of the Engineer, additional slag screenings is required said material shall be applied by the contractor. Said slag screenings shall be swept up no later than 24 hours following reapplication. No additional compensation will be allowed for reapplication and removal of slag screenings.

XII. TRAFFIC CONTROL:

The Contractor shall schedule his operations and carry out the work in a manner to cause the least disturbance and/or interference with the normal flow of traffic over the areas to be treated. Treated portions of the pavement surfaces shall be kept closed and free from traffic until penetration, in the opinion of the Engineer, has become complete and the area is suitable for traffic.

When, in the opinion of the Engineer, traffic must be maintained at all times on a particular street, then the Contractor shall apply asphalt rejuvenating agent to one lane at a time. Traffic shall be maintained in the untreated lane until the traffic may be switched to the completed lane.

The Contractor shall be responsible for all traffic control and signing required to permit safe travel. The contractor shall notify the police and fire departments as to the streets that are to be treated each day.

If, in the opinion of the Engineer, proper signing is not being used, the Contractor shall stop all operations until safe signing and barricading is achieved.

XIII. METHOD OF MEASUREMENT:

Asphalt rejuvenating agent will be measured by the square yard as provided for in the Contract Documents.

XIV. BASIS FOR PAYMENT:

The accepted quantities, measured as provided for above, will be paid for at the contract unit price for asphalt rejuvenating agent.

Asphalt rejuvenating agent shall be paid for PER SQUARE YARD, which shall be full compensation for furnishing all materials; equipment, labor and incidentals to complete the work as specified and required.

APPENDIX B

PREVAILING WAGE

AND

FEDERAL FUNDING

Prevailing Wage Contract

Yes* No

If yes:

State

Federal**

*If yes, current applicable Prevailing Wage Rates can be found on an enclosed CD-ROM disk. Please request a hard copy from the City if needed.

**If Federal, Contract Documents with contract terms relating to the federal funding are attached. (Please request documents from the City if none are attached.)

STATE OF OHIO REQUEST FOR PREVAILING WAGE RATES

Important: If you wish to retain a copy of this form for your records, please print it prior to clicking on the "Submit" button. When you click the "Submit" button, a prompt should appear which will allow you to obtain the necessary wage rates by clicking on the "view wage rates" button. Submitting this form notifies the Bureau of Labor and Worker Safety of your project. Wage rates will not be sent to you by mail as a result of the submission, rather you should obtain them by clicking on the "view wage rates" button.

Public Authority Information

Owner/Public Authority Name:	City of Gahanna	Date: 03/11/2019 This form must be filled out completely & correctly for us to process your request. Forms not completed correctly will be returned to the sender.
Department Division or Agency:	Engineering Dept.	
Street Address:	200 S. Hamilton Rd.	
Address 2:		ODOC Date Stamp
City, OH	Gahanna, OH	
ZIP:	43230	
Email:	jill.webb@gahanna.gov It is required that you list your e-mail address here.	
County of Public Authority:	FRANKLIN ▼	
P.A. Phone:	614-342-4050	

Project Information

Project Name:	2019 Street Program, ST-1064	ODOC Date Stamp (Bld Tab)
Site Address:	Various locations throughout Gahanna	
City, OH	Gahanna, OH	
ZIP:	43230	
County of Project:	FRANKLIN ▼	
Prevailing Wage Coordinator Name	Jill Webb	
Address:	Various locations throughout	
City,	Gahanna, OH	
ZIP:	43230	
Phone:	614-342-4050	
Issuing Authority of Bonds:		
Estimated Total Overall Project Cost:	\$3,657,879.20	
Type of Financing:	Local Funds	
Type of Construction:	<input type="radio"/> New Construction <input checked="" type="radio"/> Old Construction	
This Project is	<input type="radio"/> Residential <input checked="" type="radio"/> Commercial	

Expected Date of Contract Award:	<input type="text" value="05/01/19"/> example 05/31/98
Projected Completion Date:	<input type="text" value="08/13/19"/> example 05/31/98
Project Comments:	<input type="text"/> (optional)

Important: If you wish to retain a copy of this form for your records, please print it prior to clicking on the "Submit" button. When you click the "Submit" button, a prompt should appear which will allow you to obtain the necessary wage rates by clicking on the "view wage rates" button. Submitting this form notifies the Bureau of Labor and Worker Safety of your project. Wage rates will not be sent to you by mail as a result of the submission, rather you should obtain them by clicking on the "view wage rates" button.

Please contact our [Webmaster](#) with questions or comments.

LAW 1002

Prevailing Wage Determination Cover Letter

County: ▼
 Determination Date: 03/11/2019
 Expiration Date: 06/11/2019

THE FOLLOWING PAGES ARE PREVAILING RATES OF WAGES ON PUBLIC IMPROVEMENTS FAIRLY ESTIMATED TO BE MORE THAN THE AMOUNT IN O.R.C. SEC. 4115.03 (b) (1) or (2), AS APPLICABLE.

Section 4115.05 provides, in part: "Where contracts are not awarded or construction undertaken within ninety days from the date of the establishment of the prevailing wages, there shall be a redetermination of the prevailing rate of wages before the contract is awarded." The expiration date of this wage schedule is listed above for your convenience only. This wage determination is not intended as a blanket determination to be used for all projects during this period without prior approval of this Department.

Section 4115.04, Ohio Revised Code provides, in part: "Such schedule of wages shall be attached to and made a part of the specifications for the work, and shall be printed on the bidding blanks where the work is done by contract..."

The contract between the letting authority and the successful bidder shall contain a statement requiring that mechanics and laborers be paid a prevailing rate of wage as required in Section 4115.06, Ohio Revised Code.

The contractor or subcontractor is required to file with the contracting public authority upon completion of the project and prior to final payment therefore an affidavit stating that he has fully complied with Chapter 4115 of the Ohio Revised Code.

The wage rates contained in this schedule are the "Prevailing Wages" as defined by Section 4115.03, Ohio Revised Code (the basic hourly rates plus certain fringe benefits). These rates and fringes shall be a minimum to be paid under a contract regulated by Chapter 4115 of the Ohio Revised Code by contractors and subcontractors. The prevailing wage rates contained in this schedule include the effective dates and wage rates currently on file. In cases where future effective dates are not included in this schedule, modifications to the wage schedule will be furnished to the Prevailing Wage Coordinator appointed by the public authority as soon as prevailing wage rates increases are received by this office.

"There shall be posted in a prominent and accessible place on the site of work a legible statement of the Schedule of Wage Rates specified in the contract to the various classifications of laborers, workmen, and mechanics employed, said statement to remain posted during the life of such contract." Section 4115.07, Ohio Revised Code.

Apprentices will be permitted to work only under a bona fide apprenticeship program if such program exists and if such program is registered with the Ohio Apprenticeship Council.

Section 4115.071 provides that no later than ten days before the first payment of wages is due to any employee of any contractor or subcontractor working on a contract regulated by Chapter 4115, Ohio Revised Code, the contracting public authority shall appoint one of his own employees to act as the prevailing wage coordinator for said contract. The duties of the prevailing wage coordinator are outlined in Section 4115.071 of the Ohio Revised Code.

Section 4115.05 provides for an escalator in the prevailing wage rate. Each time a new rate is established, that rate is required to be paid on all ongoing public improvement projects.

A further requirement of Section 4115.05 of the Ohio Revised Code is: "On the occasion of the first pay date under a contract, the contractor shall furnish each employee not covered by a collective bargaining agreement or understanding between employers and bona fide organizations of Labor with individual written notification of the job classification to which the employee is assigned, the prevailing wage determined to be applicable to that classification, separated into the hourly rate of pay and the fringe payments, and the identity of the prevailing wage Coordinator appointed by the public authority. The contractor or subcontractor shall furnish the same notification to each affected employee every time the job classification of the employee is changed."

Work performed in connection with the installation of modular furniture may be subject to prevailing wage.

THIS PACKET IS NOT TO BE SEPARATED BUT IS TO REMAIN COMPLETE AS IT IS SUBMITTED TO YOU. (Reference guidelines and forms are included in this packet to be helpful in the compliance of the Prevailing Wage law.)
 wh1500

PREVAILING WAGE THRESHOLD LEVELS

IMPORTANT NOTICE

Before advertising for bids, contracting, or undertaking construction with its own forces, to construct a public improvement, the Public Authority shall have the Ohio Department of Commerce-Division of Industrial Compliance, Bureau of Wage and Hour Administration determine the prevailing rates of wages for workers employed on the public improvement. The wage determination must be included in the project specifications and printed on the bidding blanks where work is done by contract.

“New” construction threshold for <i>Building Construction</i>:	\$250,000
---	------------------

“Reconstruction, enlargement, alteration, repair, remodeling, renovation, or painting” threshold level for <i>Building Construction</i>:	\$75,000
---	-----------------

As of January 1, 2018:

“New” construction that involves <i>roads, streets, alleys, sewers, ditches and other works connected to road or bridge construction</i> threshold level has been adjusted to:	\$91,150
---	-----------------

“Reconstruction, enlargement, alteration, repair, remodeling, renovation, or painting” that involves <i>roads, streets, alleys, sewers, ditches and other works connected to road or bridge construction</i> threshold level has been adjusted to:	\$27,309
---	-----------------

- A) Thresholds are to be adjusted biennially by the Director of the Ohio Department of Commerce.
- B) Biennial adjustments to threshold levels are made according to the Building Cost for Skilled Labor Index published by McGraw-Hill’s Engineering News-Record, but may not increase or decrease more than 3% for any year.

If there are questions concerning this notification, please contact:

Ohio Department of Commerce
Division of Industrial Compliance
Bureau of Wage and Hour Administration
6606 Tussing Road, PO Box 4009
Reynoldsburg, Ohio 43068-9009
Phone: 614-644-2239
Fax: 614-728-8639
www.com.ohio.gov



**Department
of Commerce**

Division of Industrial Compliance

John R. Kasich, Governor
Jacqueline T. Williams, Director

Bureau of Wage and Hour Administration
6606 Tussing Road - PO Box 4009
Reynoldsburg, OH 43608-9009
Phone 614-644-2239 | Fax 614-728-8639
TTY/TDD 800-750-0750
com.ohio.gov

An Equal Opportunity Employer and Service Provider

PREVAILING WAGE CONTRACTOR RESPONSIBILITIES

This is a summary of prevailing wage contractors' responsibilities. For more detailed information please refer to Chapter 4115 of the Ohio Revised Code

General Information

Ohio's prevailing wage laws apply to all public improvements financed in whole or in part by public funds when the total overall project cost is fairly estimated to be more than \$250,000 for new construction or \$75,000 for reconstruction, enlargement, alteration, repair, remodeling, renovation, or painting.

Ohio's prevailing wage laws apply to all public improvements financed in whole or in part by public funds when the total overall project cost is fairly estimated to be more than \$91,150 for new construction that involves roads, streets, alleys, sewers, ditches and other works connected to road or bridge construction or \$27,309 for reconstruction, enlargement, alteration, repair, remodeling, renovation, or painting of a public improvement that involves roads, streets, alleys, sewers, ditches and other works connected to road or bridge construction.

- a) Thresholds are to be adjusted biennially by the Administrator of Ohio Department of Commerce, Division of Industrial Compliance and Labor, Bureau of Wage and Hour Administration
- b) Biennial adjustments to threshold levels are made according to the Price Deflator for Construction Index, United States Department of Commerce, Bureau of the Census*, but may not increase or decrease more than 3% for any year

Penalties for violation

Violators are to be assessed the wages owed, plus a penalty of 100% of the wages owed.

Intentional Violations

If an intentional violation is determined to have occurred, the contractor is prohibited from contracting directly or indirectly with any public authority for the construction of a public improvement. Intentional violation means "a willful, knowing, or deliberate disregard for any provision" of the prevailing wage law and includes but is not limited to the following actions:

- Intentional failure to submit payroll reports as required, or knowingly submitting false or erroneous reports.
- Intentional misclassification of employees for the purpose of reducing wages.
- Intentional misclassification of employees as independent contractors or as apprentices.
- Intentional failure to pay the prevailing wage.
- Intentional failure to comply with the allowable ratio of apprentices to skilled workers as required by the regulations established by Ohio Department of Commerce, Division of Industrial Compliance and Labor, Bureau of Wage and Hour Administration.
- Intentionally employing an officer, of a contractor or subcontractor, that is known to be prohibited from contracting, directly or indirectly, with a public authority.

Responsibilities

- A. Pay the prevailing rate of wages as shown in the wage rate schedules issued by the Ohio Department of Commerce, Division of Industrial Compliance and Labor, Bureau of Wage and Hour Administration, for the classification of work being performed.
 1. Wage rate schedules include all modifications, corrections, escalations, or reductions to wage rates issued for the project.

2. Overtime must be paid at time and one-half the employee's base hourly rate. Fringe benefits are paid at straight time rate for all hours including overtime.
 3. Prevailing wages must be paid in full without any deduction for food, lodging, transportation, use of tools, etc.; unless, the employee has voluntarily consented to these deductions in writing. The public authority and the Director of Ohio Department of Commerce, Division of Industrial Compliance and Labor, Bureau of Wage and Hour Administration - must approve these deductions as fair and reasonable. Consent and approval must be obtained before starting the project.
- B. Use of Apprentices and Helpers cannot exceed the ratios permitted in the wage rate schedules.
1. Apprentices must be registered with the U.S. Department of Labor Bureau of Apprenticeship and Training.
 2. Contractors must provide the Prevailing Wage Coordinator a copy of the Apprenticeship Agreement for each apprentice on the project.
- C. Keep full and accurate payroll records available for inspection by any authorized representative of the Ohio Department of Commerce, Division of Industrial Compliance, and Labor, Bureau of Wage and Hour Administration or the contracting public authority, including the Prevailing Wage Coordinator. Records should include but are not limited to:
1. Time cards, time sheets, daily work records, etc.
 2. Payroll ledger/journals and canceled checks/check register.
 3. Fringe benefit records must include program, address, account number, & canceled checks.
 4. Records made in connection with the public improvement must not be removed from the State for one year following the completion of the project.
 5. Out-of-State Corporations must submit to the Ohio Secretary of State the full name and address of their Statutory Agent in Ohio.
- D. Prevailing Wage Rate Schedule must be posted on the job site where it is accessible to all employees.
- E. Prior to submitting the initial payroll report, supply the Prevailing Wage Coordinator with your project dates to schedule reporting of your payrolls.
- F. Supply the Prevailing Wage Coordinator a list of all subcontractors including the name, address, and telephone number for each.
1. **Contractors are responsible for their subcontractors' compliance with requirements of Chapter 4115 of the Ohio Revised Code.**
- G. Before employees start work on the project, supply them with written notification of their job classification, prevailing wage rate, fringe benefit amounts, and the name of the Prevailing Wage Coordinator for the project. A copy of the completed signed notification should be submitted to Prevailing Wage Coordinator.
- H. Supply all subcontractors with the Prevailing Wage Rates and changes.
- I. Submit certified payrolls within two (2) weeks after the initial pay period. Payrolls must include the following information:
1. Employees' names, addresses, and social security numbers.
 - (a) Corporate officers/owners/partners and any salaried personnel who do physical work on the project are considered employees. All rate and reporting requirements are applicable to these individuals.
 2. Employees' work classification.
 - (a) Be specific about the laborers and/or operators (Group)
 - (b) For all apprentices, show level/year and percent of journeyman's rate
 3. Hours worked on the project for each employee.

- (a) The number of hours worked in each day and the total number of hours worked each week.
 4. Hourly rate for each employee.
 - (a) The minimum rate paid must be the wage rate for the appropriate classification. The Department's Wage Rate Schedule sets this rate.
 - (b) All overtime worked is to be paid at time and one-half for all hours worked more than forty (40) per week.
 5. Where fringes are paid into a bona fide plan instead of cash, list each benefit and amount per hour paid to program for each employee.
 - (a) When the amount contributed to the fringe benefit plan and the total number of hours worked by the employee on all projects for the year are documented, the hourly amount is calculated by dividing the total contribution of the employer by the total number of hours worked by the employee.
 - (b) When the amount contributed to the fringe benefit is documented but not the total hours worked, the hourly amount is calculated by **dividing the total yearly contribution by 2080**.
 6. Gross amount earned on all projects during the pay period.
 7. Total deductions from employee's wages.
 8. Net amount paid.
- J. The reports shall be certified by the contractor, subcontractor, or duly appointed agent stating that the payroll is correct and complete; and that the wage rates shown are not less than those required by the O.R.C. 4115.
- K. Provide a Final Affidavit to the Prevailing Wage Coordinator upon the completion of the project.



PLEASE NOTE: The Ohio Department of Commerce web services will be intermittently unavailable from March 15, 2019 @ 5 PM until March 18, 2019 @ 8 AM

INSTRUCTIONS FOR PREPARING CERTIFIED PAYROLL REPORTS

General

Contractors and subcontractors are required by law to submit certified payroll reports for work on projects covered by Ohio's Prevailing Wage Law. This form meets the reporting requirements established by Ohio Revised Code Chapter 4115. The use of this form is not mandatory, employers may submit their own forms provided that all of the required information is included. This form may be reproduced, or additional copies obtained from:

Ohio Department of Commerce Division of Industrial Compliance and Labor Bureau of Wage & Hour Administration 6606 Tussing Rd, P. O. Box 4009 Reynoldsburg, OH 43068-9009 Phone: (614) 644-2239

Certified Payroll Heading

Employer name and address: Company's full name and address. Indicate if the company is a subcontractor, if so list the name of the General or Prime. Project: Name and location of the project, including county. Contracting Public Authority: Name and address of the contracting public authority. Week Ending: Month, day, and year for last day of reporting period. Payroll #: Indicates first, second, third, etc. payroll filed by the company for the project. Page Indicator: number of pages included in the report. Project Number: Determined by the public authority. If there is no number leave blank.

Information by Column

- 1. Employee Name, Address and Social Security number: This information must be provided for all employees that perform physical labor on the project. Corporate officers, partners, and salaried employees are considered employees and must be paid the prevailing rate. Individual sole proprietors do not have to pay themselves prevailing rate but must report their hours on the project.
- 2. Work Class: List classification of work actually performed by employee. If unsure of work classification, consult the Ohio department of Commerce, Wage and Hour Bureau. Employees working more than one classification should have separate line entries for each classification. Indicate what year/level for Apprentices. Be specific when using laborer and operator classifications; for example, Backhoe Operator or Asphalt Laborer.
- 3. Hours Worked, Day & Date: In the first row of column 3 enter days of pay period example: M T W T H F S S. The second row is for the date that corresponds with each day for the pay period. In the employee information section enter the number of hours worked on the prevailing wage project and which day the hours were worked. Separate rows are labeled for (ST) straight time hours and (OT) overtime hours. All hours worked after 40, must be paid at the appropriate overtime rate.
- 4. Project Total Hours : Total the hours entered for pay period.
- 5. Base Rate: Enter actual rate per hour paid to the employee. The overtime hourly rate is time and one-half the base rate listed in the prevailing wage schedule plus fringe benefits at straight time rate. The prevailing wage schedule lists the base rate plus fringe benefit amounts. These amounts added together equal the total prevailing wage rate. Employers must pay this total amount in one of three ways,
 - Total rate may be paid in entirety in the base rate to the employee; in which case, the cash designation will be checked for fringe benefits.
 - Total rate may be paid as listed in prevailing wage rate schedule with total fringe amounts paid approved plans,
 - Total rate may be paid with a combination of base rate and fringe payments to approved plans in amounts other than those listed in schedule.
- 6. Project Gross: Enter total gross wages earned on the project for straight time and overtime. Project hours X base rate should equal project gross.
- 7. Fringes: If fringe benefits are paid in the hourly base rate, indicate this by marking the cash space. If fringe benefits are paid to approved plans as listed in the prevailing wage rate schedule, mark the space Approved Plans. If fringe benefits are paid partially in the base rate and partially to approved plans, mark the space Cash & Approved plans. List the hourly amount paid to approved plans for each fringe. If payments are not made on a per hour basis, calculate the hourly fringe credit by dividing the yearly employer contribution by the lesser of: hours actually worked in the year (these must be documented) or 2080. Fringe benefits include: Employer's share of health insurance, life insurance, retirement plan, bonus/profit sharing, sick pay, holiday pay, personal leave, vacation, and education/training programs.
- 8. Total Hours All Jobs: Total all hours worked during the pay period including non-prevailing wage jobs.
- 9. Total Gross All Jobs: Gross amount earned in the pay period for all hours worked.
- 10. Self explanatory.
- 11. Self explanatory.
- 12. Self explanatory.

CONTACT US

Division of Industrial Compliance & Labor
6606 Tussing Road
Reynoldsburg, OH 43068

Phone 614.644.2223
Fax 614.644.2618
Email IC@com.state.oh.us

Webmaster
Contact the Webmaster for Questions
or Comments on the Website:
webmaster@com.state.oh.us

CONNECT WITH US



LOOKUP SERVICES

Registered Contractor List
Boiler Information Database
Building Code Compliance Electronic Plan
Submission
Board Of Building Appeals Case Lookup
Elevator Database Lookup

RESOURCES

Federal Wage and Hour
U.S. Consumer Product Safety
Commission
National Electric, Fire Alarm and Sprinkler
Codes
Minor Labor Law Poster
2017 Minimum Wage Poster
2018 Minimum Wage Poster

**ABOUT INDUSTRIAL
COMPLIANCE**

Director Sheryl Maxfield
Interim Superintendent Geoff Eaton



Copyright©2012 Ohio Department of Commerce. All Rights Reserved.



**Department
of Commerce**

Division of Industrial Compliance

Affidavit of Compliance

Prevailing Wages

I, _____
(Name of person signing affidavit) (Title)

do hereby certify that the wages paid to all employees of

(Company Name)

for all hours worked on the

(Project name and location)

project, during the period from _____ to _____ are in
(Project Dates)

compliance with prevailing wage requirements of Chapter 4115 of the Ohio Revised Code. I further certify that no rebates or deductions have been or will be made, directly or indirectly, from any wages paid in connection with this project, other than those provided by law.

(Signature of Officer or Agent)

Sworn to and subscribed in my presence this _____ day of _____, 20_____.

(Notary Public)

The above affidavit must be executed and sworn to by the officer or agent of the contractor or subcontractor who supervises the payment of employees. This affidavit must be submitted to the owner (public authority) before the surety is released or final payment due under the terms of the contract is made.



- ▶ forms
- ▶ contacts
- ▶ about LAWS
- ▶ search

[Consumers](#)[Business](#)[License/Permit Holders & Applicants](#)[Other Government Agencies](#)

Submitting Union Contract Information

The Ohio Department of Commerce, Bureau of Wage & Hour, will no longer take union contract information for the establishment of prevailing wage rates via the web. The majority of information from the unions submitted in this manner was not supported with an associated mailing of the actual union contract and an affidavit as required. The Bureau will continue to make every effort to post up to date wage rates as efficiently as possible. In order to do so, those submitting information to the Bureau on behalf of the unions must:

- 1) submit contract information in a timely manner via fax, regular US Mail, or other non-electronic method
- 2) contract information submitted must be the actual signed union contract

Please send the appropriate information to:

Bureau of Wage & Hour
Attn: Kathy Peck
6606 Tussing Road, P.O. Box 4009
Reynoldsburg, Ohio 43068-9009

[commerce home](#) / [forms](#) / [contacts](#) / [press room](#) / [feedback](#) / [privacy policy](#)

APPENDIX C

DOCUMENTS TO BE SUBMITTED WITH BID

CONTRACTOR'S QUALIFICATION STATEMENT

ORGANIZATION:

LICENSING:

EXPERIENCE:

REFERENCES:

FINANCING:

The bidder is required to state the following in full detail as will enable the Director of Public Service and Engineering and Council of the City of Gahanna to judge its responsibility, experience, skill and financial standing to meet the obligations of the Contract.

(a) Number of years your organization has been in business as a Contractor: *

65

(b) Number of years your organization has been in business under its present business name. List any other or former names your organization has operated under. *

65

(c) If your organization is a corporation, list the following: date of incorporation, state of incorporation, President's name, Vice President's name(s), Secretary's name and Treasurer's name. If not applicable, state "not applicable." *

3/1/54...Ohio...John Strawser, President...Kyle Strawser, Vice President...Mark Pollock, Secretary/Treasurer

(d) If your organization is a partnership, list the following: date of organization, type of partnership (if applicable) and name(s) of general partner(s). If not applicable, state "not applicable." *

n/a

(e) If your organization is individually owned, list the following: date of organization and name of owner. If not applicable, state "not applicable." *

n/a

(f) If the form of your organization is other than those listed above, describe it and name the principals. If not applicable, state "not applicable." *

n/a

(a) List jurisdictions and trade categories in which your organization is legally qualified to do business, and indicate registration or license numbers, if applicable. *

Columbus..General Contractor #G02223
Sewer/Water Contractor #SW00179

(b) List jurisdictions in which your organization's partnership or trade name is filed. *

none

(a) List the categories of work that your organization normally performs with its own forces. *

milling, concrete, asphalt paving

(b) List all details of any work your organization has failed to complete. If none, state "none." *

none

(c) List any Claims that your organization or any of its officers have initiated, any Claims initiated against your organization or any of its officers, any mediation or arbitration proceedings or lawsuits related to any contract your organization or any of its officers have been involved in or is currently involved in, or any judgements or awards outstanding against your organization or any of its officers within the last five (5) years. Please give details for each Claim, including the names and telephone numbers of the persons who are parties, the amount of the Claim, the type of Claim and basis for the Claim, and the outcome. If none, state "none." *

none

Note: As used in this document "Claim" means a Claim initiated under the Contract Documents for a contract.

(d) List any officer or principal of your organization that has ever been an officer or principal of another organization when it failed to complete a contract within the last five (5) years. Please give details for each instance, including the names and telephone numbers of the persons who are parties to the contract, and the reason(s) the contract was not completed. If none, state "none." *

none

(e) List contracts your organization has in progress with an original contract sum of more than \$100,000.00, giving the name of contract, owner and its telephone number, design professional and its telephone number if applicable, contract amount, percent complete and scheduled completion date. State total amount of work in progress and under contract. If none, state "none." *

attached in financial statement upload section

(f) Provide the following information for each contract your organization has had during the last five (5) years, including current contracts, where the contract sum is fifty percent (50%) or more of the bid amount for this Contract, including add alternates: name of contract, scope of work, contract sum, name of owner's representative and owner's telephone number. *

attached in financial statement upload section

Note: If there are more than ten (10) of these contracts, only provide information on the most recent ten (10) contracts, including current contracts.

(g) Provide the following information for each contract your organization has had during the last five (5) years, which your organization believes is of comparable or greater size and complexity than the Owner's contract: name of contract, scope of work, contract sum, name of owner's representative and owner's telephone number. *

attached in financial statement upload section

Note: If there are more than five (5) of these contracts, only provide information on the most recent five (5) contracts, including current contracts.

(h) State the average annual amount of contracts your organization has performed during the last five (5) years. *

44,000,000.00

(i) If any of the following members of your organization's management, president, chairman of the board, or any director, operates or has operated another company during the last five (5) years, identify the member of management and the name of the company. If none, state "none." *

none

(j) If your organization is operating under a trade name registration with the Secretary of State for the State of Ohio, identify the entity for which the trade name is registered. If none, state "none." *

n/a

(k) If your organization is a division or wholly-owned subsidiary of another entity or has another relationship with another entity, identify the entity of which it is a division or wholly-owned subsidiary or with which it has another relationship and also identify the nature of the relationship. If not applicable, state "not applicable." *

n/a

(l) List the education, training and experience for each person who will fill a management role on the Contract, including without limitation the Contract Executive, Contract Manager and Contract Superintendent. For each person listed, include with the other information the last three contracts on which the person worked and the name and telephone number of the owner. *

Corey Strawser
11 years of experience
civil engineering degree from osu

(a) List all trade references. *

attached in financial statement upload

(b) List all bank references. *

attached in financial statement upload

(c) List the name of your surety bonding company along with the name and address of your surety agent. *

Fidelity & Deposit Company of Maryland
Kernan Insurance Agency
9932 Brewster Lane Powell, Ohio

(a) Attach a financial statement, preferably audited, including your organization's latest balance sheet and income statement showing the following items: current assets (e.g., cash, joint venture accounts, accounts receivable, notes receivable, accrued income, deposits, materials inventory and prepaid expenses), net fixed assets, other assets, current liabilities (e.g., accounts payable, notes payable, accrued expenses, provision for income taxes, advances, accrued salaries and accrued payroll taxes) and other liabilities (e.g., capital, capital stock, authorized and outstanding shares par values, earned surplus and retained earnings). (To upload - Refer to Financial Statements Upload area after the Contractor's Qualification Statement of this solicitation).

(b) List the name and address of the firm preparing attached financial statement, and date thereof. *

odot prequalification 4/232018

(c) State if the attached financial statement for the identical organization is named on page one. If not, explain the relationship and financial responsibility of the organization whose financial statement is provided (e.g., parent-subsidiary). *

organization is named on page one

(d) State if the organization whose financial statement is attached will act as guarantor of the Contract. *

organization will act as guarantor

CERTIFICATION:

The undersigned certifies for the reliance of the Owner that after diligent investigation, to the best of the undersigned's belief, the information provided with this Contractor's Qualification Statement is true, accurate and not misleading.

Company Name: *

Strawser Paving Company

Signature: *

Corey Strawser

Date: *

3/29/2019

Printed Name and Title: *

Corey Strawser, Assistant Secretary/Treasurer

CONTRACTOR'S QUALIFICATION STATEMENT (FINANCIAL STATEMENT UPLOAD)

Name	Omission Terms	Submitted File
Financial Statement Upload Financial Statement Upload		bid docs2.pdf

1 Required Document

Office of Risk Assessment
50 West Town Street
Third Floor - Suite 300
Columbus, Ohio 43215
(614)644-2658
Fax(614)644-3256
www.insurance.ohio.gov

Ohio Department of Insurance

John R. Kasich - Governor

Jillian Froment - Director



Certificate of Compliance

Issued 03/06/2018

Effective 04/02/2018

Expires 04/01/2019

I, Jillian Froment, hereby certify that I am the Director of Insurance in the State of Ohio and have supervision of insurance business in said State and as such I hereby certify that

FIDELITY AND DEPOSIT COMPANY OF MARYLAND, THE

of Maryland is duly organized under the laws of this State and is authorized to transact the business of insurance under the following section(s) of the Ohio Revised Code:

Section 3929.01 (A)

Allied Lines

Workers Compensation

Boiler & Machinery

Burglary & Theft

Commercial Auto - Liability

Commercial Auto - No Fault

Commercial Auto - Physical Damage

Credit

Earthquake

Fidelity

Financial Guaranty

Fire

Glass

Inland Marine

Multiple Peril - Commercial

Multiple Peril - Homeowners

Other Liability

Surety

FIDELITY AND DEPOSIT COMPANY OF MARYLAND, THE certified in its annual statement to this Department as of December 31, 2017 that it has admitted assets in the amount of \$214,027,811, liabilities in the amount of \$42,816,584, and surplus of at least \$171,211,226.

IN WITNESS WHEREOF, I have hereunto subscribed my name and caused my seal to be affixed at Columbus, Ohio, this day and date.

Handwritten signature of Jillian Froment in cursive script.

Jillian Froment, Director



**ZURICH AMERICAN INSURANCE COMPANY
COLONIAL AMERICAN CASUALTY AND SURETY COMPANY
FIDELITY AND DEPOSIT COMPANY OF MARYLAND
POWER OF ATTORNEY**

KNOW ALL MEN BY THESE PRESENTS: That the ZURICH AMERICAN INSURANCE COMPANY, a corporation of the State of New York, the COLONIAL AMERICAN CASUALTY AND SURETY COMPANY, a corporation of the State of Maryland, and the FIDELITY AND DEPOSIT COMPANY OF MARYLAND a corporation of the State of Maryland (herein collectively called the "Companies"), by **DAVID MCVICKER, Vice President**, in pursuance of authority granted by Article V, Section 8, of the By-Laws of said Companies, which are set forth on the reverse side hereof and are hereby certified to be in full force and effect on the date hereof, do hereby nominate, constitute, and appoint **Gerald A. KERNAN, Cheryl CRAMER, Laura BATCHELDER, Thomas J. LITMAN and Steven D. WILLIS, all of Powell, Ohio, EACH** its true and lawful agent and Attorney-in-Fact, to make, execute, seal and deliver, for, and on its behalf as surety, and as its act and deed: **any and all bonds and undertakings**, and the execution of such bonds or undertakings in pursuance of these presents, shall be as binding upon said Companies, as fully and amply, to all intents and purposes, as if they had been duly executed and acknowledged by the regularly elected officers of the ZURICH AMERICAN INSURANCE COMPANY at its office in New York, New York., the regularly elected officers of the COLONIAL AMERICAN CASUALTY AND SURETY COMPANY at its office in Owings Mills, Maryland., and the regularly elected officers of the FIDELITY AND DEPOSIT COMPANY OF MARYLAND at its office in Owings Mills, Maryland., in their own proper persons.

The said Vice President does hereby certify that the extract set forth on the reverse side hereof is a true copy of Article V, Section 8, of the By-Laws of said Companies, and is now in force.

IN WITNESS WHEREOF, the said Vice-President has hereunto subscribed his/her names and affixed the Corporate Seals of the said **ZURICH AMERICAN INSURANCE COMPANY, COLONIAL AMERICAN CASUALTY AND SURETY COMPANY, and FIDELITY AND DEPOSIT COMPANY OF MARYLAND**, this 7th day of December, A.D. 2018.

ATTEST:

**ZURICH AMERICAN INSURANCE COMPANY
COLONIAL AMERICAN CASUALTY AND SURETY COMPANY
FIDELITY AND DEPOSIT COMPANY OF MARYLAND**



Dawn E. Brown

By:

*Assistant Secretary
Dawn E. Brown*

David McVicker

*Vice President
David McVicker*

State of Maryland
County of Baltimore

On this 7th day of December, A.D. 2018, before the subscriber, a Notary Public of the State of Maryland, duly commissioned and qualified, **DAVID MCVICKER, Vice President, and DAWN E. BROWN, Assistant Secretary**, of the Companies, to me personally known to be the individuals and officers described in and who executed the preceding instrument, and acknowledged the execution of same, and being by me duly sworn, depose and saith, that he/she is the said officer of the Company aforesaid, and that the seals affixed to the preceding instrument are the Corporate Seals of said Companies, and that the said Corporate Seals and the signature as such officer were duly affixed and subscribed to the said instrument by the authority and direction of the said Corporations.

IN TESTIMONY WHEREOF, I have hereunto set my hand and affixed my Official Seal the day and year first above written.

Constance A. Dunn



Constance A. Dunn, Notary Public
My Commission Expires: July 9, 2019

EXTRACT FROM BY-LAWS OF THE COMPANIES

"Article V, Section 8, Attorneys-in-Fact. The Chief Executive Officer, the President, or any Executive Vice President or Vice President may, by written instrument under the attested corporate seal, appoint attorneys-in-fact with authority to execute bonds, policies, recognizances, stipulations, undertakings, or other like instruments on behalf of the Company, and may authorize any officer or any such attorney-in-fact to affix the corporate seal thereto; and may with or without cause modify or revoke any such appointment or authority at any time."

CERTIFICATE

I, the undersigned, Vice President of the ZURICH AMERICAN INSURANCE COMPANY, the COLONIAL AMERICAN CASUALTY AND SURETY COMPANY, and the FIDELITY AND DEPOSIT COMPANY OF MARYLAND, do hereby certify that the foregoing Power of Attorney is still in full force and effect on the date of this certificate; and I do further certify that Article V, Section 8, of the By-Laws of the Companies is still in force.

This Power of Attorney and Certificate may be signed by facsimile under and by authority of the following resolution of the Board of Directors of the ZURICH AMERICAN INSURANCE COMPANY at a meeting duly called and held on the 15th day of December 1998.

RESOLVED: "That the signature of the President or a Vice President and the attesting signature of a Secretary or an Assistant Secretary and the Seal of the Company may be affixed by facsimile on any Power of Attorney...Any such Power or any certificate thereof bearing such facsimile signature and seal shall be valid and binding on the Company."

This Power of Attorney and Certificate may be signed by facsimile under and by authority of the following resolution of the Board of Directors of the COLONIAL AMERICAN CASUALTY AND SURETY COMPANY at a meeting duly called and held on the 5th day of May, 1994, and the following resolution of the Board of Directors of the FIDELITY AND DEPOSIT COMPANY OF MARYLAND at a meeting duly called and held on the 10th day of May, 1990.

RESOLVED: "That the facsimile or mechanically reproduced seal of the company and facsimile or mechanically reproduced signature of any Vice-President, Secretary, or Assistant Secretary of the Company, whether made heretofore or hereafter, wherever appearing upon a certified copy of any power of attorney issued by the Company, shall be valid and binding upon the Company with the same force and effect as though manually affixed.

IN TESTIMONY WHEREOF, I have hereunto subscribed my name and affixed the corporate seals of the said Companies, this 29 day of March, 2019.



Brian M. Hodges

Brian M. Hodges, Vice President

TO REPORT A CLAIM WITH REGARD TO A SURETY BOND, PLEASE SUBMIT ALL REQUIRED INFORMATION TO:

Zurich American Insurance Co.
Attn: Surety Claims
1299 Zurich Way
Schaumburg, IL 60196-1056

THE FIDELITY AND DEPOSIT COMPANY

OF MARYLAND

600 Red Brook Blvd., Suite 600, Owings Mills, MD 21117

Statement of Financial Condition

As Of December 31, 2017

ASSETS

Bonds	\$ 131,463,323
Stocks	23,365,385
Cash and Short Term Investments.....	15,943,690
Reinsurance Recoverable.....	7,520,824
Federal Income Tax Recoverable.....	62,266
Other Accounts Receivable.....	<u>35,672,323</u>
TOTAL ADMITTED ASSETS	<u>\$ 214,027,811</u>

LIABILITIES, SURPLUS AND OTHER FUNDS

Reserve for Taxes and Expenses.....	\$ 580,990
Ceded Reinsurance Premiums Payable	42,235,595
Securities Lending Collateral Liability	0
TOTAL LIABILITIES	<u>\$ 42,816,584</u>
Capital Stock, Paid Up	\$ 5,000,000
Surplus	<u>166,211,227</u>
Surplus as regards Policyholders.....	<u>171,211,226</u>
TOTAL	<u>\$ 214,027,811</u>

Securities carried at \$62,198,396 in the above statement are deposited with various states as required by law.

Securities carried on the basis prescribed by the National Association of Insurance Commissioners. On the basis of market quotations for all bonds and stocks owned, the Company's total admitted assets at December 31, 2017 would be \$213,515,173 and surplus as regards policyholders \$170,698,588.

I, DENNIS F. KERRIGAN, Corporate Secretary of the FIDELITY AND DEPOSIT COMPANY OF MARYLAND, do hereby certify that the foregoing statement is a correct exhibit of the assets and liabilities of the said Company on the 31st day of December, 2017.

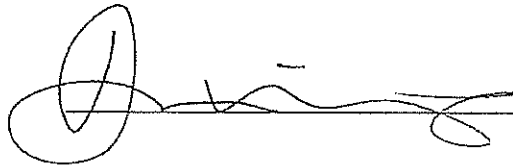

 Corporate Secretary

State of Illinois }
 City of Schaumburg } SS:

Subscribed and sworn to, before me, a Notary Public of the State of Illinois, in the City of Schaumburg, this 9th day of March, 2018.



 Notary Public



CONTRACTOR'S QUALIFICATION STATEMENT

On a separate sheet, the bidder is required to state the following in full detail as will enable the Director of Public Service and Engineering and Council of the City of Gahanna to judge its responsibility, experience, skill and financial standing to meet the obligations of the Contract.

ORGANIZATION.

- (a) Number of years your organization has been in business as a Contractor.
- (b) Number of years your organization has been in business under its present business name. List any other or former names your organization has operated under.
- (c) If your organization is a corporation, list the following: date of incorporation, state of incorporation, President's name, Vice President's name(s), Secretary's name and Treasurer's name. If not applicable, state "not applicable."
- (d) If your organization is a partnership, list the following: date of organization, type of partnership (if applicable) and name(s) of general partner(s). If not applicable, state "not applicable."
- (e) If your organization is individually owned, list the following: date of organization and name of owner. If not applicable, state "not applicable."
- (f) If the form of your organization is other than those listed above, describe it and name the principals. If not applicable, state "not applicable."

LICENSING.

- (a) List jurisdictions and trade categories in which your organization is legally qualified to do business, and indicate registration or license numbers, if applicable.
- (b) List jurisdictions in which your organization's partnership or trade name is filed.

EXPERIENCE.

- (a) List the categories of work that your organization normally performs with its own forces.
- (b) List all details of any work your organization has failed to complete. If none, state "none."
- (c) List any Claims that your organization or any of its officers have initiated, any Claims initiated against your organization or any of its officers, any mediation or arbitration proceedings or lawsuits related to any contract your organization or any of its officers have been involved in or is currently involved in, or any judgements or awards outstanding against your organization or any of its officers within the last five (5) years. Please attach details for each Claim, including the names and telephone numbers of the persons who are parties, the amount of the Claim, the type of Claim and basis for the Claim, and the outcome. If none, state "none."

Note: As used in this document "Claim" means a Claim initiated under the Contract Documents for a contract.

(d) List any officer or principal of your organization that has ever been an officer or principal of another organization when it failed to complete a contract within the last five (5) years. Please attach details for each instance, including the names and telephone numbers of the persons who are parties to the contract, and the reason(s) the contract was not completed. If none, state "none."

(e) List contracts your organization has in progress with an original contract sum of more than \$100,000.00, giving the name of contract, owner and its telephone number, design professional and its telephone number if applicable, contract amount, percent complete and scheduled completion date. State total amount of work in progress and under contract. If none, state "none."

(f) Provide the following information for each contract your organization has had during the last five (5) years, including current contracts, where the contract sum is fifty percent (50%) or more of the bid amount for this Contract, including add alternates: name of contract, scope of work, contract sum, name of owner's representative and owner's telephone number.

Note: If there are more than ten (10) of these contracts, only provide information on the most recent ten (10) contracts, including current contracts.

(g) Provide the following information for each contract your organization has had during the last five (5) years, which your organization believes is of comparable or greater size and complexity than the Owner's contract: name of contract, scope of work, contract sum, name of owner's representative and owner's telephone number.

Note: If there are more than five (5) of these contracts, only provide information on the most recent five (5) contracts, including current contracts.

(h) State the average annual amount of contracts your organization has performed during the last five (5) years.

(i) If any of the following members of your organization's management, president, chairman of the board, or any director, operates or has operated another company during the last five (5) years, identify the member of management and the name of the company. If none, state "none."

(j) If your organization is operating under a trade name registration with the Secretary of State for the State of Ohio, identify the entity for which the trade name is registered. If none, state "none."

(k) If your organization is a division or wholly-owned subsidiary of another entity or has another relationship with another entity, identify the entity of which it is a division or wholly-owned subsidiary or with which it has another relationship and also identify the nature of the relationship. If none, state "not applicable."

(l) List the education, training and experience for each person who will fill a management role on the Contract, including without limitation the Contract Executive, Contract Manager and Contract Superintendent. For each person listed, include with the other information the last three contracts on which the person worked and the name and telephone number of the owner.

REFERENCES.

(a) List all trade references.

(b) List all bank references.

(c) List the name of your surety bonding company along with the name and address of your surety agent.

FINANCING.

(a) Attach a financial statement, preferably audited, including your organization's latest balance sheet and income statement showing the following items: current assets (e.g., cash, joint venture accounts, accounts receivable, notes receivable, accrued income, deposits, materials inventory and prepaid expenses), net fixed assets, other assets, current liabilities (e.g., accounts payable, notes payable, accrued expenses, provision for income taxes, advances, accrued salaries and accrued payroll taxes) and other liabilities (e.g., capital, capital stock, authorized and outstanding shares par values, earned surplus and retained earnings).

(b) List the name and address of the firm preparing attached financial statement, and date thereof.

(c) State if the attached financial statement for the identical organization is named on page one. If not, explain the relationship and financial responsibility of the organization whose financial statement is provided (e.g., parent-subsiary).

(d) State if the organization whose financial statement is attached will act as guarantor of the Contract.

CERTIFICATION.

The undersigned certifies for the reliance of the Owner that after diligent investigation, to the best of the undersigned's belief, the information provided with this Contractor's Qualification Statement is true, accurate and not misleading.

Company Name

Signature

Date

Printed Name and Title

_____, being duly sworn, deposes and says that the information provided herein is true and sufficiently complete so as not to be misleading.

Sworn to and subscribed in my presence this ____ day of _____, 20____.

Notary Public

My Commission Expires: _____

Seal:

SUBCONTRACTORS LIST

The bidder is required to state, in detail, in the space provided below, the name, address, experience and the work to be performed by subcontractors in this Contract, including approximate percentage of the Contract cost by subcontractor. If no subcontractors are to be used, so state. *

phenix stabilization - stabilization (Gahanna street program previous years) 1595 frank rd. Columbus, oh 43223
griffin pavement striping- striping (Gahanna street program previous years) 2383 Harrison rd. Columbus, oh 43204
complete general construction - rcc (Gahanna street program previous years) 1221 e fifth ave. Columbus, oh

Note: The bidder shall perform within its own organization, work amounting to not less than fifty percent (50%) of the total Contract cost.

CORPORATE AFFIDAVIT

Optional: Vendor is not required to complete.

To be filled in and executed if the contractor is a corporation.

State of: *

Ohio

County of (ss): *

Franklin

_____ ,
being first duly sworn, *

Mark Pollock

deposes and says that he or she is Secretary of

_____, *
Strawser Paving Co., Inc.

a corporation organized and existing under and by virtue of the laws of the state of

_____, *
ohio

and having its principal office at

_____, *
1595 frank rd., columbus, oh 43223

(Address), *

(City), *

columbus

(County), *

franklin

(State). *

ohio

Affiant further says he or she is familiar with the records, minutes, books and by-laws of the _____
(Name of Corporation). *

strawser paving co., inc.

Affiant further says that

_____, *
corey strawsers

(Name of Officer), *

(Title) *

assistant secretary/assistant treasurer

of the Corporation is duly authorized to sign the Contract for the _____ (Contract) *

2019 Street Program ST-1064

for said Corporation by virtue of _____ (state whether a provision of by-laws or a resolution of the Board of Directors), *

by laws

_____ (if by resolution, give date of adoption).

Signature: *

Mark Pollock

CORPORATE AFFIDAVIT

To be filled in and executed if the contractor is a corporation.

STATE OF _____,

COUNTY OF _____, ss:

_____, being first duly sworn, deposes and says that he or she is Secretary of _____, a corporation organized and existing under and by virtue of the laws of the state of _____ and having its principal office at: _____ (Address), _____ (City), _____ (County), _____ (State).

Affiant further says he or she is familiar with the records, minutes, books and by-laws of the _____ (Name of Corporation).

Affiant further says that _____ (Name of Officer), _____ (Title) of the Corporation is duly authorized to sign the Contract for the _____ (Contract) for said Corporation by virtue of _____ (state whether a provision of by-laws or a resolution of the Board of Directors), _____ (if by resolution, give date of adoption).

Signature

Sworn to and subscribed in my presence this _____ day of _____, 20_____.

Notary Public

My Commission Expires: _____

Seal:

CONTRACTOR'S PERSONAL PROPERTY TAX AFFIDAVIT (O.R.C. § 5719.042)

being first duly sworn, deposes and says:

the Contractor:

State of: *

Ohio

County of (ss): *

Franklin

_____, **Affiant, ***

Corey Strawser

1. I am the (Title): *

Assistant Secretary/Treasurer

of (Contractor): *

Strawser Paving Company

2. The Contractor's offices are located at: *

1595 Frank Road Columbus, Ohio 43223

3. I am the Contractor's duly authorized representative for making this affidavit.

4. Effective this _____ day: *

29th

of _____: *

march

20 _____: *

19

is charged with delinquent personal property taxes on the general list of personal property as set forth below:

County:

Amount (include total amount, with penalties and interest thereon):

County:

Amount (include total amount, with penalties and interest thereon):

County:

Amount (include total amount, with penalties and interest thereon):

County:

Amount (include total amount, with penalties and interest thereon):

is not charged with delinquent personal property taxes on the general list of personal property in any Ohio county.

Signature: *

Corey Strawser

CONTRACTOR'S PERSONAL PROPERTY TAX AFFIDAVIT
(O.R.C § 5719.042)

STATE OF _____,

COUNTY OF _____, ss:

_____, Affiant, being first duly sworn, deposes and says:

1. I am the _____ (Title) of _____ (Contractor).
2. The Contractor's offices are located at _____

3. I am the Contractor's duly authorized representative for making this affidavit.
4. Effective this _____ day of _____, 20____, the Contractor:

() is charged with delinquent personal property taxes on the general list of personal property as set forth below:

County	Amount (include total amount, with penalties and interest thereon)
_____ County	\$ _____
_____ County	\$ _____
_____ County	\$ _____
_____ County	\$ _____

() is not charged with delinquent personal property taxes on the general list of personal property in any Ohio county.

Affiant Signature

Sworn to and subscribed in my presence this _____ day of _____, 20_____.

Notary Public

My Commission Expires: _____

Seal:

NONCOLLUSION AFFIDAVIT

State of: *

Ohio

County of (ss): *

Franklin

Contractor, *

Corey Strawser

being first duly sworn, deposes and says that he or she is

*

secretary

of

(company name), *

Strawser Paving Company

the party making the foregoing bid; that such bid is not made in the interest of or on behalf of any undisclosed person, partnership, company, association, organization, or corporation; that such bid is genuine and not collusive or sham; that said bidder has not directly or indirectly induced or solicited any other bidder to put in a false or sham bid, and has not directly or indirectly colluded, conspired, connived, or agreed with any bidder or anyone else to put in a sham bid, or that any one shall refrain from bidding; that said bidder has not in any manner, directly or indirectly, sought by agreement, communication or conference with anyone to fix any overhead, profit, or cost element of such bid price, or of that of any other bidder, or to secure any advantage against the Owner awarding the Contract to anyone interested in the proposed Contract; that all statements contained in such bid are true; and further, that said bidder has not, directly or indirectly, submitted its bid price or any breakdown thereof, or the contents thereof, or divulged information or data relative thereto, or paid and will not pay any fee in connection therewith, to any corporation, partnership, company, association, organization, bid depository, or to any member or agent thereof, or to any other individual except to such person or persons as have a partnership or other financial interest with said bidder in its general business.

Signature: *

Corey Strawser

NONCOLLUSION AFFIDAVIT

STATE OF _____,

COUNTY OF _____, ss:

_____, Contractor, being first duly sworn, deposes and says that he or she is _____ (sole owner, a partner, president, secretary, etc.) of _____, the party making the foregoing bid; that such bid is not made in the interest of or on behalf of any undisclosed person, partnership, company, association, organization, or corporation; that such bid is genuine and not collusive or sham; that said bidder has not directly or indirectly induced or solicited any other bidder to put in a false or sham bid, and has not directly or indirectly colluded, conspired, connived, or agreed with any bidder or anyone else to put in a sham bid, or that any one shall refrain from bidding; that said bidder has not in any manner, directly or indirectly, sought by agreement, communication or conference with anyone to fix any overhead, profit, or cost element of such bid price, or of that of any other bidder, or to secure any advantage against the Owner awarding the Contract to anyone interested in the proposed Contract; that all statements contained in such bid are true; and further, that said bidder has not, directly or indirectly, submitted its bid price or any breakdown thereof, or the contents thereof, or divulged information or data relative thereto, or paid and will not pay any fee in connection therewith, to any corporation, partnership, company, association, organization, bid depository, or to any member or agent thereof, or to any other individual except to such person or persons as have a partnership or other financial interest with said bidder in its general business.

Signature

Sworn to and subscribed in my presence this _____ day of _____, 20_____.

Notary Public

My Commission Expires: _____

Seal:

ESCROW WAIVER

Contractor, *

Strawser Paving Co., Inc.

agrees to abide by City of Gahanna Ordinance No. 0077-2017. Pursuant to such ordinance and the City's home rule authority, Contractor waives the requirements of Sections 153.13, 153.14 and 153.63 of the Ohio Revised Code that an escrow account be established relating to the Contract and that interest be paid on retainage.

Signature: *

Corey strawser

ESCROW WAIVER

_____ (Contractor), agrees to abide by City of Gahanna Ordinance No. 0077-2017. Pursuant to such ordinance and the City's home rule authority, Contractor waives the requirements of Sections 153.13, 153.14 and 153.63 of the Ohio Revised Code that an escrow account be established relating to the Contract and that interest be paid on retainage.

Signature

Sworn to and subscribed in my presence this ____ day of _____, 20____.

Notary Public

My Commission Expires: _____

Seal:

BID GUARANTY AND CONTRACT BOND (O.R.C § 153.571)

Know all persons by these presents, that we, the undersigned
_____ (Contractor) *

Strawser Paving Co., Inc.

as principal and
_____ (Surety
Company) *

fidelity and deposit company of maryland

as surety are hereby held and firmly bound unto the City of Gahanna, as obligee in the penal sum of the dollar amount of the bid submitted by the principal to the obligee on

_____ (Month & Day), *

march 29th

20_____ (Year), *

19

to undertake the the construction of _____ (Project Name) *

2019 Street Program ST-1064

The penal sum referred to herein shall be the dollar amount of the principal's bid to the obligee, incorporating any additive or deductive Alternates made by the principal on the date referred to above to the obligee, which are accepted by the obligee. In no case shall the penal sum exceed the amount of _____ Dollars (in words)

\$:

(If the foregoing blank is not filled in, the penal sum will be the full amount of the principal's bid, including add alternates. Alternatively, if the blank is filled in the amount stated must not be less than the full amount of the bid including add alternates, in dollars and cents. A percentage is not acceptable.) For the payment of the penal sum well and truly to be made, we hereby jointly and severally bind ourselves, our heirs, executors, administrators, successors, and assigns.

Signed this _____ day: *

29th

of _____: *

march

20_____: *

19

The condition of the above obligations is such that whereas the above named principal has submitted a bid for work on the Contract.

Now, therefore, if the obligee accepts the bid of the principal and the principal fails to enter into a proper contract in accordance with the bid, plans, details, specifications and bills of material; and in the event the principal pays to the obligee the difference not to exceed ten percent (10%) of the penalty hereof between the amount specified in the bid and such larger amount for which the obligee may in good faith contract with the next lowest bidder to perform the work covered by the bid; or in the event the obligee does not award the contract to the next lowest bidder and resubmits the contract for bidding, the principal pays to the obligee the difference not-to-exceed ten percent (10%) of the penalty hereof between the amount specified in the bid, or the costs, in connection with the resubmission, of printing new contract documents, required advertising, and printing and mailing notices to prospective bidders, whichever is less, then this obligation shall be null and void, otherwise to remain in full force and effect; if the obligee accepts the bid of the principal and the principal within ten (10) days after the awarding of the contract enters into a proper contract in accordance with the bid, plans, details, specifications and bills of material, which said contract is made a part of this bond the same as though set forth herein.

Now also, if the said principal shall well and faithfully do and perform the things agreed by said principal to be done and performed according to the terms of said contract; and shall pay all lawful claims of subcontractors, materialmen, and laborers, for labor performed and materials furnished in the carrying forward, performing, or completing of said contract; we agreeing and assenting that this undertaking shall be for the benefit of any materialman or laborer having a just claim, as well as for the obligee herein; then this obligation shall be void; otherwise the same shall remain in full force and effect; and surety shall indemnify the obligee against all damage suffered by failure of the principal to perform the contract according to its provisions and in accordance with the plans, details, specifications and bills of material therefor and to pay all lawful claims of subcontractors, materialmen, and laborers for labor performed or material furnished in carrying forward, performing, or completing the contract and surety further agrees and assents that this undertaking is for the benefit of any subcontractor, materialman, or laborer having a just claim, as well as for the obligee; it being expressly understood and agreed that the liability of the surety for any and all claims hereunder shall in no event exceed the penal amount of this obligation as herein stated.

The said surety hereby stipulates and agrees that no modifications, omissions, or additions in or to the terms of the said contract or in or to the plans or specifications therefore shall in any wise affect the obligations of said surety on its bond, and does hereby waive notice of any such modifications, omissions or additions to the terms of the contract or to the work or to the specifications.

Signed and sealed this _____ day: *

29th

of _____: *

march

20 _____: *

19

Principal *

strawser paving co., inc.

Signature *

Corey Strawser

Printed Name and Title *

corey strawser assistant secretary/assistant treasurer

**BID GUARANTY AND CONTRACT BOND
(SURETY SIGNATURE PAGE)**

SURETY COMPANY

Fidelity and Deposit Company of Maryland

Surety

Laura M. Batchelder

Signature

Laura M. Batchelder / Attorney-in-Fact

Printed Name and Title

Six PPG Place, Suite 800, Pittsburgh, PA 15222

Surety's Address

412-937-5462

Surety's Telephone Number

412-263-2144

Surety's Fax Number

SURETY AGENT

Kernan Insurance Agency, Inc.

Surety's Agent

9932 Brewster Lane, Powell, OH 43065

Surety Agent's Address

614-764-0121

Surety Agent's Telephone Number

614-764-6914

Surety Agent's Fax Number

BID GUARANTY AND CONTRACT BOND (ATTACHMENT LIST)

Surety Signature Page

Contact information and signatures of surety company and surety agent

BID GUARANTY AND CONTRACT BOND (SURETY UPLOADS)

Name	Omission Terms	Submitted File
Surety Signature Page (refer to attachment listed above) Contact information and signatures of surety company and surety agent		surety signature page.pdf
Power of Attorney Power of attorney		surety poa.pdf
Surety Financial Statement Surety financial statement		surety financials.pdf
Certificate of Compliance for Ohio Certificate of compliance for Ohio		surety coc.pdf
4 Required Documents		

BID FORM & BIDDER CERTIFICATION

When the Bidder is a partnership or a joint venture, state name and address of each partner in the partnership or participant in the joint venture below:

Having carefully reviewed the Information and Requirements for Bidders, Drawings, Specifications and other Contract Documents for the Project including having also received, read, and taken into account any Addenda and likewise having inspected the site and the conditions affecting and governing the Project and confirmed the location of the site utilities and all existing structures, the undersigned hereby proposes to furnish all materials and to perform all labor, as specified and described in the said Specifications and/or as shown on the said Drawings for all Work necessary to complete the Project on a timely basis and in accordance with the Contract Documents regardless of whether expressly provided for in such Specifications and Drawings.

Before completing the Bid Form, the undersigned represents that it has carefully reviewed the Notice to Bidders, Information and Requirements for Bidders, this Bid Form, Form of Bid Guaranty and Contract Bond, Contractor's Affidavit (O.R.C. 5719.042), Owner-Contractor Agreement, General Conditions of the Contract (EJCDC C-700, 2013) (as modified), Drawings, Project Specifications, and all other Contract Documents. Failure to comply with provisions of the Contract Documents may be cause for disqualification of the bid.

BONDS AND CONTRACT: If the undersigned is notified of bid acceptance, it agrees to furnish required bonds as indicated in the Information and Requirements for Bidders.

COMPLETION OF WORK: In submitting a bid, the undersigned agrees to execute the Owner-Contractor Agreement in the form included in the Contract Documents and to substantially complete its Work as required by the Contract Documents.

NOTE A: The wording of the Bid Form shall be used throughout, without change, alteration, or addition. Any change may cause it to be rejected.

NOTE B: Bidder is cautioned to bid only on the Brands or Standards specified.

NOTE C: If there is an inconsistency or conflict in the Bid amount, the lowest amount shall control, whether expressed in numbers or words.

INSTRUCTIONS FOR SIGNING

A. The person signing for a sole proprietorship must be the sole proprietor or his authorized representative. The name of the sole proprietor must be shown below.

B. The person signing for a partnership must be a partner or his authorized representative.

C. The person signing for a corporation must be the president, vice president or other authorized representative; or he must show authority, by affidavit, to bind the corporation.

D. The person signing for some other legal entity must show his authority, by affidavit, to bind the legal entity.

BIDDER CERTIFICATIONS. The Bidder hereby acknowledges that the following representations in this bid are material and not mere recitals:

1. The Bidder acknowledges that this is a public project involving public funds, and that the Owner expects and requires that each successful Bidder adhere to the highest ethical and performance standards. The Bidder by submitting its bid pledges and agrees that (a) it will act at all times with absolute integrity and truthfulness in its dealings with the Owner and the Design Professional, (b) it will use its best efforts to cooperate with the Owner and the Design Professional and all other Contractors on the Project and at all times will act with professionalism and dignity in its dealings with the Owner, Design Professional and other Contractors, (c) it will assign only competent supervisors and workers to the Project, each of whom is fully qualified to perform the tasks that are assigned to him/her, and (d) it has read, understands and will comply with the terms of the Contract Documents.
2. The Bidder represents that it has had a competent person carefully and diligently review each part of the Contract Documents, including the Divisions of the Specifications and parts of the Drawings that are not directly applicable to the Work on which the Bidder is submitting its bid. By submitting its bid, each Bidder represents and agrees, based upon its careful and diligent review of the Contract Documents, that it is not aware of any conflicts, inconsistencies, errors or omissions in the Contract Documents for which it has not notified the Design Professional in writing at least seven (7) days prior to the bid opening. If there are any such conflicts, inconsistencies, errors or omissions in the Contract Documents, the Bidder (i) will provide the labor, equipment or materials of the better quality or greater quantity of Work; and/or (ii) will comply with the more stringent requirements. The Bidder will not be entitled to any additional compensation for any conflicts, inconsistencies, errors or omissions that would have been discovered by such careful and diligent review, unless it has given such prior written notice to Design Professional.
3. The Bidder represents that it has had a competent person carefully and diligently inspect and examine the entire site for the Project and the surrounding area, including all parts of the site applicable to the Work for which it is submitting its bid, including the location, condition and layout of the site and the location of utilities, and carefully correlate the results of the inspection with the requirements of the Contract Documents. The Bidder agrees that its bid shall include all costs attributable to site and surrounding area conditions that would have been discovered by such careful and diligent inspection and examination of the site and the surrounding area, and the Bidder shall not be entitled to any Change Order, additional compensation, or additional time on account of conditions that could not have been discovered by such an investigation.
4. The Bidder represents, understands and agrees that a) the Change Proposal and Claim procedures in the Modified Standard General Conditions are material terms of the Contract Documents, b) if it has a Change Proposal or Claim, it will have its personnel provide complete and accurate information to complete and submit the Change Proposal and / or Statement of Claim form on a timely basis, c) the proper completion and timely submission of a Change Proposal or Statement of Claim form is a condition precedent to any change in the Contract Sum or the Contract Time(s), and d) the proper and timely submission of the Change Proposal or Statement of Claim form provides the Owner and the Design Professional with necessary information so that the Owner may investigate the Claim and mitigate its damages.
5. The Bidder represents that the bid contains the name of every person interested therein and is based upon the Standards specified by the Contract Documents.
6. The Bidder and each person signing on behalf of the Bidder certifies, and in the case of a bid by joint venture, each member thereof certifies as to such member's entity, under penalty of perjury, that to the best of the undersigned's knowledge and belief: (a) the Base Bid, any Unit Prices, Lump Sum Items, and any Alternate bids in the bid have been arrived at independently without collusion, consultation, communication or agreement, or for the purpose of restricting competition as to any matter relating to such Base Bid, Unit Prices, Lump Sum Items, or Alternate bids with any other Bidder; (b) unless otherwise required by law, the Base Bid, any Unit Prices, Lump Sum Items, and any Alternate bids in the bid have not been knowingly disclosed by the Bidder and will not knowingly be disclosed by the Bidder prior to the bid opening, directly or indirectly, to any other Bidder who would have any interest in the Base Bid, Unit Prices, Lump Sum Items, or Alternate bids; (c) no attempt has been made or will be made by the Bidder to induce any other Person to submit or not to submit a bid for the purpose of restricting competition; and (d) the statements made in this Bid Form are true and correct.
7. The Bidder will execute the form of Owner/Contractor Agreement in the form included with the Contract Documents, if a Contract is awarded on the basis of this bid, and if the Bidder does not execute the Contract Form for any reason, other than as authorized by law, the Bidder and the Bidder's Surety are liable to the Owner.
8. The Bidder certifies that upon the award of a Contract, the Contractor will ensure that all of the Contractor's employees, while working on the Project site, will not purchase, transfer, use or possess illegal drugs or alcohol or abuse prescription drugs in any way.
9. The Bidder agrees to furnish any information requested by the Design Professional or the Owner's authorized representative to evaluate that the Bidder is the best bidder and that the bid is responsive to the specifications.
10. The Bidder certifies that it has no unresolved findings for recovery issued by the Auditor of State.

11. The Bidder certifies that it is aware of and in compliance with the requirements of Ohio Revised Code Section 3517.13 regarding campaign contributions.

Legal Name of Bidder: *

Strawser Paving Company

Bidder is: *

corporation

Name and Title of Person Legally Authorized to Bind Bidder to a Contract: *

corey strawser assistant secretary/assistant treasurer

Address: *

1595 Frank Road Columbus, Ohio 43223

Telephone Number: *

(614) 276-5273

Fax Number:

(614) 276-7565

Federal Tax ID Number: *

314412354

Signature: *

corey strawser

Date: *

3/29/2019

Name and Address:

BID GUARANTY AND CONTRACT BOND
(O.R.C § 153.571)

Know all persons by these presents, that we, the undersigned _____
(Contractor) as principal and _____ as surety are hereby
held and firmly bound unto the City of Gahanna, as obligee in the penal sum of the dollar amount of the
bid submitted by the principal to the obligee on _____, 20____, to undertake the
_____ (Project).

The penal sum referred to herein shall be the dollar amount of the principal's bid to the obligee,
incorporating any additive or deductive alternates made by the principal on the date referred to above to
the obligee, which are accepted by the obligee. In no case shall the penal sum exceed the amount of
_____ dollars (\$_____).

(If the foregoing blank is not filled in, the penal sum will be the full amount of the principal's bid,
including add alternates. Alternatively, if the blank is filled in the amount stated must not be less than the
full amount of the bid including add alternates, in dollars and cents. A percentage is not acceptable.) For
the payment of the penal sum well and truly to be made, we hereby jointly and severally bind ourselves,
our heirs, executors, administrators, successors, and assigns.

Signed this _____ day of _____, 20_____.

The condition of the above obligations is such that whereas the above named principal has submitted a
bid for work on the Contract.

Now, therefore, if the obligee accepts the bid of the principal and the principal fails to enter into a proper
contract in accordance with the bid, plans, details, specifications and bills of material; and in the event the
principal pays to the obligee the difference not to exceed ten percent (10%) of the penalty hereof
between the amount specified in the bid and such larger amount for which the obligee may in good faith
contract with the next lowest bidder to perform the work covered by the bid; or in the event the obligee
does not award the contract to the next lowest bidder and resubmits the contract for bidding, the
principal pays to the obligee the difference not-to-exceed ten percent (10%) of the penalty hereof
between the amount specified in the bid, or the costs, in connection with the resubmission, of printing
new contract documents, required advertising, and printing and mailing notices to prospective bidders,
whichever is less, then this obligation shall be null and void, otherwise to remain in full force and effect; if
the obligee accepts the bid of the principal and the principal within ten (10) days after the awarding of the
contract enters into a proper contract in accordance with the bid, plans, details, specifications and bills of
material, which said contract is made a part of this bond the same as though set forth herein.

Now also, if the said principal shall well and faithfully do and perform the things agreed by said principal
to be done and performed according to the terms of said contract; and shall pay all lawful claims of
subcontractors, materialmen, and laborers, for labor performed and materials furnished in the carrying
forward, performing, or completing of said contract; we agreeing and assenting that this undertaking shall
be for the benefit of any materialman or laborer having a just claim, as well as for the obligee herein; then
this obligation shall be void; otherwise the same shall remain in full force and effect; and surety shall
indemnify the obligee against all damage suffered by failure of the principal to perform the contract
according to its provisions and in accordance with the plans, details, specifications and bills of material
therefor and to pay all lawful claims of subcontractors, materialmen, and laborers for labor performed or
material furnished in carrying forward, performing, or completing the contract and surety further agrees
and assents that this undertaking is for the benefit of any subcontractor, materialman, or laborer having a

just claim, as well as for the obligee; it being expressly understood and agreed that the liability of the surety for any and all claims hereunder shall in no event exceed the penal amount of this obligation as herein stated.

The said surety hereby stipulates and agrees that no modifications, omissions, or additions in or to the terms of the said contract or in or to the plans or specifications therefore shall in any wise affect the obligations of said surety on its bond, and does hereby waive notice of any such modifications, omissions or additions to the terms of the contract or to the work or to the specifications.

Signed and sealed this _____ day of _____, 20_____.

Principal

Signature

Printed Name and Title

Surety

Signature

Printed Name and Title

Surety's Address

Surety's Telephone Number

Surety's Fax Number

Surety's Agent

Surety Agent's Address

Surety Agent's Telephone Number

Surety Agent's Fax Number

BID FORM

Having carefully reviewed the Information and Requirements for Bidders, Drawings, Specifications and other Contract Documents for the Project including having also received, read, and taken into account any Addenda and likewise having inspected the site and the conditions affecting and governing the Project and confirmed the location of the site utilities and all existing structures, the undersigned hereby proposes to furnish all materials and to perform all labor, as specified and described in the said Specifications and/or as shown on the said Drawings for all Work necessary to complete the Project on a timely basis and in accordance with the Contract Documents regardless of whether expressly provided for in such Specifications and Drawings.

Before completing the Bid Form, the undersigned represents that it has carefully reviewed the Notice to Bidders, Information and Requirements for Bidders, this Bid Form, Form of Bid Guaranty and Contract Bond, Contractor's Affidavit (O.R.C. 5719.042), Owner-Contractor Agreement, General Conditions of the Contract (EJCDC C-700, 2013) (as modified), Drawings, Project Specifications, and all other Contract Documents. Failure to comply with provisions of the Contract Documents may be cause for disqualification of the bid.

If the undersigned is notified of bid acceptance, it agrees to furnish required bonds as indicated in the Information and Requirements for Bidders and agrees to execute the Owner-Contractor Agreement in the form included in the Contract Documents and to furnish all equipment, labor and materials to complete the said work as required by the Contract Documents. If the undersigned shall fail to furnish required bonds as indicated in the Information and Requirements for Bidders, then the Owner, in its sole discretion, may determine that the undersigned had abandoned the Contract and thereupon its bid shall be null and void and the bond accompanying its bid shall be forfeited to and become the property of the Owner, otherwise the bond accompanying its bid shall be returned to the undersigned on demand.

BIDDER CERTIFICATINS. The Bidder hereby acknowledges that the following representations in this bid are material and not mere recitals:

1. The Bidder acknowledges that this is a public project involving public funds, and that the Owner expects and requires that each successful Bidder adhere to the highest ethical and performance standards. The Bidder by submitting its bid pledges and agrees that (a) it will act at all times with absolute integrity and truthfulness in its dealings with the Owner and the Design Professional, (b) it will use its best efforts to cooperate with the Owner and the Design Professional and all other Contractors on the Project and at all times will act with professionalism and dignity in its dealings with the Owner, Design Professional and other Contractors, (c) it will assign only competent supervisors and workers to the Project, each of whom is fully qualified to perform the tasks that are assigned to him/her, and (d) it has read, understands and will comply with the terms of the Contract Documents.
2. The Bidder represents that it has had a competent person carefully and diligently review each part of the Contract Documents, including the Divisions of the Specifications and parts of the Drawings that are not directly applicable to the Work on which the Bidder is submitting its bid. By submitting its bid, each Bidder represents and agrees, based upon its careful and diligent review of the Contract Documents, that it is not aware of any conflicts, inconsistencies, errors or omissions in the Contract Documents for which it has not notified the Design Professional in writing at least seven (7) days prior to the bid opening. If there are any such conflicts, inconsistencies, errors or omissions in the Contract Documents, the Bidder (i) will provide the labor, equipment or materials of the better quality or greater quantity of Work; and/or (ii) will

comply with the more stringent requirements. The Bidder will not be entitled to any additional compensation for any conflicts, inconsistencies, errors or omissions that would have been discovered by such careful and diligent review, unless it has given such prior written notice to Design Professional.

3. The Bidder represents that it has had a competent person carefully and diligently inspect and examine the entire site for the Project and the surrounding area, including all parts of the site applicable to the Work for which it is submitting its bid, including the location, condition and layout of the site and the location of utilities, and carefully correlate the results of the inspection with the requirements of the Contract Documents. The Bidder agrees that its bid shall include all costs attributable to site and surrounding area conditions that would have been discovered by such careful and diligent inspection and examination of the site and the surrounding area, and the Bidder shall not be entitled to any Change Order, additional compensation, or additional time on account of conditions that could not have been discovered by such an investigation.

4. The Bidder represents, understands and agrees that a) the Change Proposal and Claim procedures in the Modified Standard General Conditions are material terms of the Contract Documents, b) if it has a Change Proposal or Claim, it will have its personnel provide complete and accurate information to complete and submit the Change Proposal and / or Statement of Claim form on a timely basis, c) the proper completion and timely submission of a Change Proposal or Statement of Claim form is a condition precedent to any change in the Contract Sum or the Contract Time(s), and d) the proper and timely submission of the Change Proposal or Statement of Claim form provides the Owner and the Design Professional with necessary information so that the Owner may investigate the Claim and mitigate its damages.

5. The Bidder represents that the bid contains the name of every person interested therein and is based upon the Standards specified by the Contract Documents.

6. The Bidder and each person signing on behalf of the Bidder certifies, and in the case of a bid by joint venture, each member thereof certifies as to such member's entity, under penalty of perjury, that to the best of the undersigned's knowledge and belief: (a) the Base Bid, any Unit Prices, Lump Sum Items, and any Alternate bids in the bid have been arrived at independently without collusion, consultation, communication or agreement, or for the purpose of restricting competition as to any matter relating to such Base Bid, Unit Prices, Lump Sum Items, or Alternate bids with any other Bidder; (b) unless otherwise required by law, the Base Bid, any Unit Prices, Lump Sum Items, and any Alternate bids in the bid have not been knowingly disclosed by the Bidder and will not knowingly be disclosed by the Bidder prior to the bid opening, directly or indirectly, to any other Bidder who would have any interest in the Base Bid, Unit Prices, Lump Sum Items, or Alternate bids; (c) no attempt has been made or will be made by the Bidder to induce any other Person to submit or not to submit a bid for the purpose of restricting competition; and (d) the statements made in this Bid Form are true and correct.

7. The Bidder will execute the form of Owner/Contractor Agreement in the form included with the Contract Documents, if a Contract is awarded on the basis of this bid, and if the Bidder does not execute the Contract Form for any reason, other than as authorized by law, the Bidder and the Bidder's Surety are liable to the Owner.

8. The Bidder certifies that upon the award of a Contract, the Contractor will ensure that all of the Contractor's employees, while working on the Project site, will not purchase, transfer, use or possess illegal drugs or alcohol or abuse prescription drugs in any way.

9. The Bidder agrees to furnish any information requested by the Design Professional or the Owner's authorized representative to evaluate that the Bidder is the best bidder and that the bid is responsive to the specifications.

10. The Bidder certifies that it has no unresolved findings for recovery issued by the Auditor of State.

11. The Bidder certifies that it is aware of and in compliance with the requirements of Ohio Revised Code Section 3517.13 regarding campaign contributions.

INSTRUCTIONS FOR SIGNING. The person signing for a sole proprietorship must be the sole proprietor or his or her authorized representative. The name of the sole proprietor must be shown below. The person signing for a partnership must be a partner or his or her authorized representative. The person signing for a corporation must be the president, vice president or other authorized representative; or he or she must show authority, by affidavit, to bind the corporation. The person signing for some other legal entity must show his or her authority, by affidavit, to bind the legal entity.

Legal Name of Bidder

Bidder is (check one): sole proprietor partnership corporation other legal entity

Name and Title of Person Legally Authorized to Bind Bidder to a Contract

Address

Telephone Number

Fax Number

Federal Tax ID Number

Signature

Date

When the Bidder is a partnership or a joint venture, state name and address of each partner in the partnership or participant in the joint venture below:

Name and Address

Name and Address

BID FORM (INSTRUCTIONS)

Include the cost of all labor and material for the bid items listed below. Bidder is to fill in all blanks related to the bid items for which a bid is being submitted. If there is a difference between the total bid amount and the total of the individual amounts for labor and materials stated under a bid item, the total of the individual amounts shall be the amount deemed to be inserted in the blank for the total labor and materials for each bid item. If there is an inconsistency or conflict in the bid amount, the lowest amount shall control, whether expressed in numbers or words.

The pricing of the alternate is mandatory. The City may select the base bid only, or a combination of the base bid with the alternate bid to determine the lowest and best bidder.

BID FORM

Include the cost of all labor and material for the bid items listed below. Bidder is to fill in all blanks related to the bid items for which a bid is being submitted. If there is a difference between the total bid amount and the total of the individual amounts for labor and materials stated under a bid item, the total of the individual amounts shall be the amount deemed to be inserted in the blank for the total labor and materials for each bid item. If there is an inconsistency or conflict in the bid amount, the lowest amount shall control, whether expressed in numbers or words.

The pricing of the alternate is mandatory. The City may select the base bid only, or a combination of the base bid with the alternate bid to determine the lowest and best bidder.

BID FORM

\$3,486,489.41

REF #	ITEM #	DESCRIPTION	QTY	UNIT	MATERIAL	LABOR	Extension
1	203	Excavation	1.00	LS	\$0.00	\$170,000.00	\$170,000.00
2	SPEC	Cement Stabilization	26,033.00	SY	\$3.00	\$7.25	\$266,838.25
3	254	1" to 3" Planing	62,460.15	SY	\$0.00	\$1.75	\$109,305.26
4	SPEC	7" Roller Compacted Concrete Base	13,836.00	SY	\$10.00	\$14.75	\$342,441.00
5	407	Tack Coat (Trackless)	8,853.00	GAL	\$3.00	\$1.50	\$39,838.50
6	410	Traffic Compacted Surface	450.00	CY	\$5.00	\$5.00	\$4,500.00
7	413	Crack Seal	122,857.00	SY	\$0.20	\$0.25	\$55,285.65
8	418	Sawing & Sealing Asphalt Concrete Pavement Joint	1.00	LS	\$1,000.00	\$21,000.00	\$22,000.00
9	448	1-1/2" Asphalt Concrete, Intermediate Course	3,426.00	CY	\$109.00	\$39.00	\$507,048.00
10	448	1-1/2" Asphalt Concrete, Surface Course	3,540.00	CY	\$126.00	\$42.00	\$594,720.00
11	448	1-1/2" Asphalt Concrete, Surface Course 70-22M	865.00	CY	\$142.00	\$39.00	\$156,565.00
12	608	5' Concrete Walk	25,750.00	SF	\$1.50	\$5.25	\$173,812.50
13	608	Curb Ramp, Type C (ADA Compliant Reconfiguration)	74.00	EA	\$300.00	\$1,150.00	\$107,300.00
14	609	Combination Curb & Gutter Inc. 4" Underdrain	9,314.00	LF	\$8.00	\$11.00	\$176,966.00
15	609	Curb Replacement	7,503.00	LF	\$7.00	\$25.00	\$240,096.00
16	614	Maintenance of Traffic	1.00	LS	\$0.00	\$44,000.00	\$44,000.00
17	623	Construction Layout Stakes	1.00	LS	\$200.00	\$9,800.00	\$10,000.00
18	644	Crosswalk 12"	5,169.00	LF	\$1.00	\$1.50	\$12,922.50
19	644	Crosswalk 24"	140.00	LF	\$2.00	\$4.00	\$840.00
20	644	Stop Line	1,201.00	LF	\$2.00	\$3.50	\$6,605.50

REF #	ITEM #	DESCRIPTION	QTY	UNIT	MATERIAL	LABOR	Extension
21	653 & 659	Topsoil, Seeding & Mulching	1.00	LS	\$10,000.00	\$12,000.00	\$22,000.00
22	608	Curb Ramp, Type C (Truncated Dome Replacement)	15.00	EA	\$150.00	\$300.00	\$6,750.00
23	SPEC	Asphalt Expansion Joints	14.00	EA	\$300.00	\$1,150.00	\$20,300.00
24	SPEC	Remove/Replace Base of Concrete Drives	914.00	SY	\$25.00	\$48.50	\$67,179.00
25	SPEC	Remove/Reset Curb Inlet	13.00	EA	\$50.00	\$245.00	\$3,835.00

BID FORM

\$3,486,489.41

REF #	ITEM #	DESCRIPTION	QTY	UNIT	MATERIAL	LABOR	Extension
26	644	Edge Line, White	1.14	MI	\$1,000.00	\$1,300.00	\$2,622.00
27	644	Edge Line, Yellow	0.08	MI	\$1,000.00	\$1,300.00	\$184.00
28	644	Lane Line	1.34	MI	\$750.00	\$750.00	\$2,010.00
29	644	Center Line	3.20	MI	\$2,000.00	\$2,000.00	\$12,800.00
30	644	Channelizing Line	2,203.00	LF	\$0.50	\$1.00	\$3,304.50
31	644	Transverse Line, White	495.00	LF	\$1.00	\$4.25	\$2,598.75
32	644	Chevron	33.00	LF	\$1.50	\$4.50	\$198.00
33	644	School Symbol Marking	2.00	EA	\$200.00	\$350.00	\$1,100.00
34	644	Lane Arrow	62.00	EA	\$50.00	\$40.00	\$5,580.00
35	644	Word on Pavement, 96"	13.00	EA	\$50.00	\$55.00	\$1,365.00
36	644	Island Marking	60.00	SF	\$1.00	\$2.00	\$180.00
37	644	Dotted Line Double Yellow	180.00	LF	\$0.75	\$1.25	\$360.00
38	644	Dotted Line, 6"	550.00	LF	\$0.50	\$1.00	\$825.00
39	644	Parking Line	7,440.00	LF	\$0.50	\$1.00	\$11,160.00
40	644	Handicap Symbol	7.00	EA	\$50.00	\$55.00	\$735.00
41	304	Embankment using Item 304 8"	2,740.00	CY	\$19.00	\$16.00	\$95,900.00
42	617	Aggregate Berm	9,716.00	LF	\$0.50	\$1.00	\$14,574.00
43	SPEC	Full Depth Pavement Repair	1,505.00	SY	\$30.00	\$39.00	\$103,845.00
44	SPEC	McCutcheon and Stygler Traffic Signal Improvement	1.00	EA	\$40,000.00	\$26,000.00	\$66,000.00
Total:							\$3,486,489.41

BID FORM (ALTERNATE BID)

REF #	ITEM #	DESCRIPTION	QTY	UNIT	MATERIAL	LABOR	Extension
45	SPEC	Reclamite Asphalt Rejuvenating Agent	88,494.00	SY	\$0.50	\$0.45	\$84,069.30
Alternate Total: \$84,069.30							
Total:							

Bid Tab

Name of Project: 2019 STREET PROGRAM, ST-1064

Contractor: _____

Address: _____

Bid Opening: March 29, 2019 @ 11:00 am

Phone Number: () - _____

Base Bid								
Ref #	Item #	Description	Unit	Qty	Labor	Material	Unit Price	Bid Price
1	203	Excavation	LS	1			\$ -	\$ -
2	SPEC	Cement Stabilization	SY	26,033			\$ -	\$ -
3	254	1" to 3" Planing	SY	62,460.15			\$ -	\$ -
4	SPEC	7" Roller Compacted Concrete Base	SY	13,836			\$ -	\$ -
5	407	Tack Coat (Trackless)	GAL	8,853			\$ -	\$ -
6	410	Traffic Compacted Surface	CY	450			\$ -	\$ -
7	413	Crack Seal	SY	122,857			\$ -	\$ -
8	418	Sawing & Sealing Asphalt Concrete Pavement Joint	LS	1			\$ -	\$ -
9	448	1-1/2" Asphalt Concrete, Intermediate Course	CY	3,426			\$ -	\$ -
10	448	1-1/2" Asphalt Concrete, Surface Course	CY	3,540			\$ -	\$ -
11	448	1-1/2" Asphalt Concrete, Surface Course 70-22M	CY	865			\$ -	\$ -
12	608	5' Concrete Walk	SF	25,750			\$ -	\$ -
13	608	Curb Ramp, Type C (ADA Compliant Reconfiguration)	EA	74			\$ -	\$ -
14	609	Combination Curb & Gutter Inc. 4" Underdrain	LF	9,314			\$ -	\$ -
15	609	Curb Replacement	LF	7,503			\$ -	\$ -
16	614	Maintenance of Traffic	LS	1			\$ -	\$ -
17	623	Construction Layout Stakes	LS	1			\$ -	\$ -
18	644	Crosswalk 12"	LF	5,169			\$ -	\$ -
19	644	Crosswalk 24"	LF	140			\$ -	\$ -
20	644	Stop Line	LF	1,201			\$ -	\$ -
21	653 & 659	Topsoil, Seeding & Mulching	LS	1			\$ -	\$ -
22	608	Curb Ramp, Type C (Truncated Dome Replacement)	EA	15			\$ -	\$ -
23	SPEC	Asphalt Expansion Joints	EA	14			\$ -	\$ -
24	SPEC	Remove/Replace Base of Concrete Drives	SY	914			\$ -	\$ -
25	SPEC	Remove/Reset Curb Inlet	EA	13			\$ -	\$ -
26	644	Edge Line, White	MI	1.14			\$ -	\$ -
27	644	Edge Line, Yellow	MI	0.08			\$ -	\$ -
28	644	Lane Line	MI	1.34			\$ -	\$ -
29	644	Center Line	MI	3.20			\$ -	\$ -
30	644	Channelizing Line	LF	2,203.00			\$ -	\$ -
31	644	Transverse Line, White	LF	495.00			\$ -	\$ -
32	644	Chevron	LF	33			\$ -	\$ -
33	644	School Symbol Marking	EA	2			\$ -	\$ -
34	644	Lane Arrow	EA	62			\$ -	\$ -

Bid Tab

Name of Project: 2019 STREET PROGRAM, ST-1064

Contractor: _____

Address: _____

Bid Opening: March 29, 2019 @ 11:00 am

Phone Number: () - _____

35	644	Word on Pavement, 96"	EA	13			\$ -	\$ -
36	644	Island Marking	SF	60			\$ -	\$ -
37	644	Dotted Line Double Yellow	LF	180			\$ -	\$ -
38	644	Dotted Line, 6"	LF	550			\$ -	\$ -
39	644	Parking Line	LF	7,440			\$ -	\$ -
40	644	Handicap Symbol	EA	7			\$ -	\$ -
41	304	Embankment using Item 304 8"	CY	2,740			\$ -	\$ -
42	617	Aggregate Berm	LF	9,716			\$ -	\$ -
43	SPEC	Full Depth Pavement Repair	SY	1,505			\$ -	\$ -
44	SPEC	McCutcheon and Stygler Traffic Signal Improvement	EA	1			\$ -	\$ -

TOTAL (BASE BID): \$ -

Bid Tab

Name of Project: 2019 STREET PROGRAM, ST-1064

Contractor: _____

Address: _____

Bid Opening: March 29, 2019 @ 11:00 am

Phone Number: () - _____

ALTERNATE BID

The pricing of the alternate is mandatory. The City may select the base bid only, or a combination of the base bid with the alternate bid to determine the lowest and best bidder.

ALTERNATE 1

Ref #	Item #	Description	Unit	Qty	Labor	Material	Unit Price	Total
45	SPEC	Reclamite Asphalt Rejuvenating Agent	SY	88,494			\$ -	\$ -

TOTAL (Alternate 1): \$ -

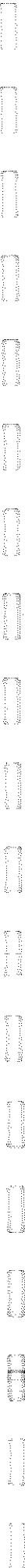

APPENDIX D

Detail Sheets Typical Section 2019 Street Program Map

Detroit Street Rebuild Details

Name of Project: 2019 STREET PROGRAM - ST 1064

Street Name

Detroit Rebuilds

Spec Item	Description	Unit	2019 QTY's	Douglas Dr		Headley Parking Lot		Healey Parking Lot		Flintwood Dr	Quantity
				Quantity	Quantity	Quantity	Quantity				
304	Embankment using Item 304 8"	CY	2740.00								
203	Excavation	LS	11.00	1.00	2.00						1.00
SPEC	Cement Stabilization	SY	26033.00	2,500.00	9,160.00						1,593.00
SPEC	7" Roller Compacted Concrete Base	SY	13836.00	2,493.00							1,591.00
407	Tack Coat (Trackless)	GAL	2603.00	249.00	916.00						160.00
410	Traffic Compacted Surface	CY	450.00	50.00							50.00
418	Sawing & Sealing Asphalt Concrete Pavement Joint	LS	7.50	1.00							1.00
448	1-1/2" Asphalt Concrete, Intermediate Course	CY	1594.00	104.00	763.00						66.00
448	1-1/2" Asphalt Concrete, Surface Course	CY	1088.00	104.00	382.00						66.00
608	5' Concrete Walk	SF	21240.00	8,720.00	1,450.00						
608	Curb Ramp, Type C (ADA Compliant Reconfiguration)	EA	26.00	2.00							6.00
609	Combination Curb & Gutter Inc. 4" Underdrain	LF	9314.00	1,795.00							1,170.00
614	Maintenance of Traffic	LS	7.50	1.00							1.00
623	Construction Layout Stakes	LS	7.50	1.00							1.00
644	Parking Line	LF	7440.00		5,460.00						
644	Handicap Symbol	EA	7.00	0.00	4.00						
644	Crosswalk 12"	LF	676.00	52.00							156.00
644	Stop Line	LF	182.00	28.00							28.00
653 & 659	Topsoil, Seeding & Mulching	LS	7.70	1.00	0.10						1.00
SPEC	Asphalt Expansion Joints	EA	14.00	2.00							2.00
SPEC	Remove/Replace Base of Concrete Drives	SY	914.00	142.00							96.00
SPEC	Remove/Reset Curb Inlet	EA	13.00	3.00							3.00

From

To

Nob Hill Ct S
Cherrybottom Rd
Nob Hill Dr. S +

Flintwood Dr
McCUTCHEON Rd
Baywood Dr

Douglas Dr
Gary Lee Dr
Jahn Dr

Headley Parking Lot
Large Lot

Healey Parking Lot
Small Lot

Quantity	Quantity	Quantity	Quantity
679.00	1.50	3,016.00	302.00

Quantity	Quantity	Quantity	Quantity
2,061.00	2.00	9,160.00	916.00

Quantity	Quantity	Quantity	Quantity
840.00	0.50	0.50	4.00

Quantity	Quantity	Quantity	Quantity
1,170.00	1.00	1.00	6.00

Quantity	Quantity	Quantity	Quantity
156.00	28.00	0.50	1.00

Quantity	Quantity	Quantity	Quantity
2.00	1.00	64.00	3.00

Detroit Street Rebuild Details

Name of Project: 2019 STREET PROGRAM - ST 1064

Street Name

Detroit Rebuilds

Spec Item	Description	Unit	Quantity
304	Embankment using Item 304 8"	CY	
203	Excavation	LS	0.50
SPEC	Cement Stabilization	SY	1,002.00
SPEC	7" Roller Compacted Concrete Base	SY	1,001.00
407	Tack Coat (Trackless)	GAL	100.00
410	Traffic Compacted Surface	CY	50.00
418	Sawing & Sealing Asphalt Concrete Pavement Joint	LS	0.50
448	1-1/2" Asphalt Concrete, Intermediate Course	CY	43.00
448	1-1/2" Asphalt Concrete, Surface Course	CY	43.00
608	5' Concrete Walk	SF	
608	Curb Ramp, Type C (ADA Compliant Reconfiguration)	EA	
609	Combination Curb & Gutter Inc. 4" Underdrain	LF	555.00
614	Maintenance of Traffic	LS	0.50
623	Construction Layout Stakes	LS	0.50
644	Parking Line	LF	
644	Handicap Symbol	EA	
644	Crosswalk 12"	LF	
644	Stop Line	LF	
653 & 659	Topsoil, Seeding & Mulching	LS	0.50
SPEC	Asphalt Expansion Joints	EA	1.00
SPEC	Remove/Replace Base of Concrete Drives	SY	90.00
SPEC	Remove/Reset Curb Inlet	EA	

From	To	Quantity
Nob Hill Ct N	Nob Hill Dr S	
Nob Hill Ct	Nob Hill Dr W	
End of Ct		

From	To	Quantity
Nob Hill Dr S	Nob Hill Dr W	
Nob Hill Ct	Nob Hill Dr W	
End of Ct		

From	To	Quantity
Lancewood Dr	Denwood Dr N	
Denwood Dr N	McCutcheson Rd	
McCutcheson Rd		

From	To	Quantity
Jahn Dr	Granville St	
Granville St	Jahn Ct++	
Jahn Ct++		

From	To	Quantity
Jahn Dr	Jahn Ct-	
Jahn Ct-	Gary Lee Dr	
Gary Lee Dr		

Spec Item	Description	Unit	Quantity
304	Embankment using Item 304 8"	CY	
203	Excavation	LS	0.50
SPEC	Cement Stabilization	SY	1,430.00
SPEC	7" Roller Compacted Concrete Base	SY	1,428.00
407	Tack Coat (Trackless)	GAL	143.00
410	Traffic Compacted Surface	CY	50.00
418	Sawing & Sealing Asphalt Concrete Pavement Joint	LS	1.00
448	1-1/2" Asphalt Concrete, Intermediate Course	CY	60.00
448	1-1/2" Asphalt Concrete, Surface Course	CY	60.00
608	5' Concrete Walk	SF	
608	Curb Ramp, Type C (ADA Compliant Reconfiguration)	EA	
609	Combination Curb & Gutter Inc. 4" Underdrain	LF	1,020.00
614	Maintenance of Traffic	LS	1.00
623	Construction Layout Stakes	LS	1.00
644	Parking Line	LF	
644	Handicap Symbol	EA	0.00
644	Crosswalk 12"	LF	
644	Stop Line	LF	
653 & 659	Topsoil, Seeding & Mulching	LS	1.00
SPEC	Asphalt Expansion Joints	EA	1.00
SPEC	Remove/Replace Base of Concrete Drives	SY	135.00
SPEC	Remove/Reset Curb Inlet	EA	2.00

Spec Item	Description	Unit	Quantity
304	Embankment using Item 304 8"	CY	
203	Excavation	LS	0.50
SPEC	Cement Stabilization	SY	998.00
SPEC	7" Roller Compacted Concrete Base	SY	997.00
407	Tack Coat (Trackless)	GAL	100.00
410	Traffic Compacted Surface	CY	50.00
418	Sawing & Sealing Asphalt Concrete Pavement Joint	LS	0.50
448	1-1/2" Asphalt Concrete, Intermediate Course	CY	42.00
448	1-1/2" Asphalt Concrete, Surface Course	CY	42.00
608	5' Concrete Walk	SF	
608	Curb Ramp, Type C (ADA Compliant Reconfiguration)	EA	4.00
609	Combination Curb & Gutter Inc. 4" Underdrain	LF	644.00
614	Maintenance of Traffic	LS	0.50
623	Construction Layout Stakes	LS	0.50
644	Parking Line	LF	
644	Handicap Symbol	EA	0.00
644	Crosswalk 12"	LF	
644	Stop Line	LF	
653 & 659	Topsoil, Seeding & Mulching	LS	104.00
SPEC	Asphalt Expansion Joints	EA	1.00
SPEC	Remove/Replace Base of Concrete Drives	SY	52.00
SPEC	Remove/Reset Curb Inlet	EA	2.00

Spec Item	Description	Unit	Quantity
304	Embankment using Item 304 8"	CY	
203	Excavation	LS	1.00
SPEC	Cement Stabilization	SY	1,984.00
SPEC	7" Roller Compacted Concrete Base	SY	1,982.00
407	Tack Coat (Trackless)	GAL	198.00
410	Traffic Compacted Surface	CY	50.00
418	Sawing & Sealing Asphalt Concrete Pavement Joint	LS	1.00
448	1-1/2" Asphalt Concrete, Intermediate Course	CY	83.00
448	1-1/2" Asphalt Concrete, Surface Course	CY	83.00
608	5' Concrete Walk	SF	
608	Curb Ramp, Type C (ADA Compliant Reconfiguration)	EA	5,765.00
609	Combination Curb & Gutter Inc. 4" Underdrain	LF	1,211.00
614	Maintenance of Traffic	LS	1.00
623	Construction Layout Stakes	LS	1.00
644	Parking Line	LF	
644	Handicap Symbol	EA	
644	Crosswalk 12"	LF	
644	Stop Line	LF	
653 & 659	Topsoil, Seeding & Mulching	LS	156.00
SPEC	Asphalt Expansion Joints	EA	3.00
SPEC	Remove/Replace Base of Concrete Drives	SY	74.00
SPEC	Remove/Reset Curb Inlet	EA	2.00

Spec Item	Description	Unit	Quantity
304	Embankment using Item 304 8"	CY	
203	Excavation	LS	1.00
SPEC	Cement Stabilization	SY	1,560.00
SPEC	7" Roller Compacted Concrete Base	SY	1,558.00
407	Tack Coat (Trackless)	GAL	156.00
410	Traffic Compacted Surface	CY	50.00
418	Sawing & Sealing Asphalt Concrete Pavement Joint	LS	1.00
448	1-1/2" Asphalt Concrete, Intermediate Course	CY	65.00
448	1-1/2" Asphalt Concrete, Surface Course	CY	65.00
608	5' Concrete Walk	SF	
608	Curb Ramp, Type C (ADA Compliant Reconfiguration)	EA	5,305.00
609	Combination Curb & Gutter Inc. 4" Underdrain	LF	2.00
614	Maintenance of Traffic	LS	1,117.00
623	Construction Layout Stakes	LS	1.00
644	Parking Line	LF	1.00
644	Handicap Symbol	EA	
644	Crosswalk 12"	LF	
644	Stop Line	LF	
653 & 659	Topsoil, Seeding & Mulching	LS	0.00
SPEC	Asphalt Expansion Joints	EA	
SPEC	Remove/Replace Base of Concrete Drives	SY	52.00
SPEC	Remove/Reset Curb Inlet	EA	14.00
SPEC	Remove/Reset Curb Inlet	EA	1.00
SPEC	Remove/Reset Curb Inlet	EA	2.00
SPEC	Remove/Reset Curb Inlet	EA	91.00
SPEC	Remove/Reset Curb Inlet	EA	2.00

Detroit Street Rebuild Details

Name of Project: 2019 STREET PROGRAM - ST 1064

Street Name: Cotswold Pl

Detroit Rebuilds

Spec Item	Description	Unit	Quantity
304	Embankment using Item 304.8"	CY	
203	Excavation	LS	1.00
SPEC	Cement Stabilization	SY	1,607.00
SPEC	7" Roller Compacted Concrete Base	SY	1,605.00
407	Tack Coat (Trackless)	GAL	161.00
410	Traffic Compacted Surface	CY	50.00
418	Sawing & Sealing Asphalt Concrete Pavement Joint	LS	1.00
448	1-1/2" Asphalt Concrete, Intermediate Course	CY	67.00
448	1-1/2" Asphalt Concrete, Surface Course	CY	67.00
608	5' Concrete Walk	SF	
608	Curb Ramp, Type C (ADA Compliant Reconfiguration)	EA	2.00
609	Combination Curb & Gutter Inc. 4" Underdrain	LF	962.00
614	Maintenance of Traffic	LS	1.00
623	Construction Layout Stakes	LS	1.00
644	Parking Line	LF	
644	Handicap Symbol	EA	0.00
644	Crosswalk 12"	LF	52.00
644	Stop Line	LF	14.00
653 & 659	Topsoil, Seeding & Mulching	LS	1.00
SPEC	Asphalt Expansion Joints	EA	1.00
SPEC	Remove/Replace Base of Concrete Drives	SY	170.00
SPEC	Remove/Reset Curb Inlet	EA	

From	Moorfield Dr
To	End of Ct

Resurfacing Details

Name of Project: 2019 STREET PROGRAM - ST 1064

Street Name

Resurfacing Projects

From	To
Taylor Rd	500 ft South of Hamilton Rd

Bid Opening:

Spec Item	Description	Unit	2019 QTY'S	Quantity
254	1" to 3" Planning	SY	62,460.15	
407	Tack Coat (Trackless)	GAL	6,250.00	
448	1-1/2" Asphalt Concrete, Intermediate Course	CY	1,832.00	
448	1-1/2" Asphalt Concrete, Surface Course	CY	2,452.00	
448	1-1/2" Asphalt Concrete, Surface Course 70-22M	CY	865.00	
608	Curb Ramp, Type C (ADA Compliant Reconfiguration)	EA	48.00	
609	Curb Replacement	LF	7,503.00	2,548.00
644	Crosswalk 12"	LF	2,303.00	
644	Stop Line	LF	479.00	
608	Curb Ramp, Type C (Truncated Dome Replacement)	EA	15.00	
617	Aggregate Berm	LF	9,716.00	
SPEC	Full Depth Pavement Repair	SY	1,505.00	245

Goshen Ln Base Repair	Quantity
Hermitage	
W. Johnstown	
	190

Taylor Station Base Repair	Quantity
Research Rd	
Taylor Rd	
	235.00

Resurfacing Details

Name of Project: 2019 STREET PROGRAM - ST 1064

Resurfacing Projects

Bid

Opening:

Spec Item	Description	Unit	Quantity	Street Name
				From To
254	1" to 3" Planing	SY	5,320.00	Rice Avenue
407	Tack Coat (Trackless)	GAL	532.00	Taylor Rd
448	1-1/2" Asphalt Concrete, Intermediate Course	CY	222.00	Howland Dr
448	1-1/2" Asphalt Concrete, Surface Course	CY	222.00	
448	1-1/2" Asphalt Concrete, Surface Course 70-22M	CY		
608	Curb Ramp, Type C (ADA Compliant Reconfiguration)	EA	2.00	
609	Curb Replacement	LF	240.00	
644	Crosswalk 12"	LF		
644	Stop Line	LF	14.00	
608	Curb Ramp, Type C (Truncated Dome Replacement)	EA		
617	Aggregate Berm	LF		
SPEC	Full Depth Pavement Repair	SY		

Quantity	Street Name
4,945.00	Helmbright Dr
495.00	Trifecta Ct +
207.00	Leaflock Ct -
207.00	
8.00	
880.00	
340.00	
56.00	
6.00	

Quantity	Street Name
1,725.00	Caroway Blvd
173.00	Farm Creek Dr
72.00	Cloverly Dr
72.00	
115.00	
200.00	
35.00	
2.00	

Quantity	Street Name
3,306.00	Uxbridge Ave
331.00	Clark St Rd
138.00	Picadilly Ct -
138.00	
2.00	
900.00	
200.00	
35.00	
2.00	

Resurfacing Details

Name of Project: 2019 STREET PROGRAM - ST 1064

Resurfacing Projects

Bid

Opening:

Spec Item	Description	Unit	Quantity	Street Name	
				From	To
				Riva Ridge Blvd	
				Sugar Hill Pl	
				Woodtown Dr	
254	1" to 3" Planing	SY	3,625.00		
407	Tack Coat (Trackless)	GAL	363.00		
448	1-1/2" Asphalt Concrete, Intermediate Course	CY	151.00		
448	1-1/2" Asphalt Concrete, Surface Course	CY	151.00		
448	1-1/2" Asphalt Concrete, Surface Course 70-22M	CY			
608	Curb Ramp, Type C (ADA Compliant Reconfiguration)	EA	4.00		
609	Curb Replacement	LF	150.00		
644	Crosswalk 12"	LF	104.00		
644	Stop Line	LF	28.00		
608	Curb Ramp, Type C (Truncated Dome Replacement)	EA			
617	Aggregate Berm	LF			
SPEC	Full Depth Pavement Repair	SY			

Beecher Rd		Quantity
	N. Hamilton Rd	2,004.00
	Ridge Crest Dr -	201.00
		84.00
		84.00
		150.00

Cannonade Ct		Quantity
	Arcaro Dr	2,955.00
	End of Ct	296.00
		128.00
		128.00
		2.00
		120.00
		52.00
		14.00

Highmeadow Dr		Quantity
	Ashburnham Dr	3,020.00
	Brookhill Dr/Greencroft Rd	302.00
		126.00
		126.00
		4.00
		180.00
		112.00
		28.00

Resurfacing Details

Name of Project: 2019 STREET PROGRAM - ST 1064

Resurfacing Projects

Bid

Opening:

Spec Item	Description	Unit	Quantity
254	1" to 3" Planing	SY	5,266.00
407	Tack Coat (Trackless)	GAL	527.00
448	1-1/2" Asphalt Concrete, Intermediate Course	CY	220.00
448	1-1/2" Asphalt Concrete, Surface Course	CY	220.00
448	1-1/2" Asphalt Concrete, Surface Course 70-22M	CY	
608	Curb Ramp, Type C (ADA Compliant Reconfiguration)	EA	10.00
609	Curb Replacement	LF	350.00
644	Crosswalk 12"	LF	320.00
644	Stop Line	LF	46.00
608	Curb Ramp, Type C (Truncated Dome Replacement)	EA	
617	Aggregate Berm	LF	
SPEC	Full Depth Pavement Repair	SY	

Street Name	From	To	Quantity
Brookhill Dr	Glenhurst Ct	Cherry Bottom Rd	
			4,406.00
			441.00
			245.00
			5,778.00

Street Name	From	To	Quantity
McCutcheon Rd	Stygler Rd	Corp Limit	
			14,716.15
			1,472.00
			620.00
			620.00
			10.00
			850.00
			715.00
			132.00

Street Name	From	To	Quantity
S. Hamilton Rd	Techcenter	270 South off Ramp	
			665.00
			66.00
			30.00
			30.00
			80.00

Resurfacing Details

Name of Project: 2019 STREET PROGRAM - ST 1064

Resurfacing Projects

Bid

Opening:

Spec Item	Description	Unit	Quantity	Street Name
				From
				Lindenhaven Rd
				Lindenhaven Ct
				Woodmark Run
254	1" to 3" Planing	SY	2,312.00	
407	Tack Coat (Trackless)	GAL	231.00	
448	1-1/2" Asphalt Concrete, Intermediate Course	CY	97.00	
448	1-1/2" Asphalt Concrete, Surface Course	CY	97.00	
448	1-1/2" Asphalt Concrete, Surface Course 70-22M	CY		
608	Curb Ramp, Type C (ADA Compliant Reconfiguration)	EA		
609	Curb Replacement	LF	160.00	
644	Crosswalk 12"	LF	52.00	
644	Stop Line	LF	14.00	
608	Curb Ramp, Type C (Truncated Dome Replacement)	EA	2.00	
617	Aggregate Berm	LF		
SPEC	Ful Depth Pavement Repair	SY		

Quantity	Street Name
1,950.00	Imperial Dr
195.00	Baroness Way +
82.00	Prince of Wales Dr +
82.00	
450.00	
156.00	
56.00	
5.00	

Quantity	Street Name
1,386.00	S. High St
139.00	Clark St
60.00	Granville St
60.00	
6.00	
40.00	
200.00	
42.00	

Quantity	Street Name
3,723.00	Olde Ridenour
372.00	Stonegate
165.00	Carlin Ct
165.00	
260.00	
3,938.00	
755.00	

Resurfacing Details

Name of Project: 2019 STREET PROGRAM - ST 1064

Street Name: Amcliff Ct

Resurfacing Projects

From: Moorfield Dr
To: End of Ct

Bid Opening:

Spec Item	Description	Unit	Quantity
254	1" to 3" Planing	SY	1,136.00
407	Tack Coat (Trackless)	GAL	114.00
448	1-1/2" Asphalt Concrete, Intermediate Course	CY	50.00
448	1-1/2" Asphalt Concrete, Surface Course	CY	50.00
448	1-1/2" Asphalt Concrete, Surface Course 70-22M	CY	
608	Curb Ramp, Type C (ADA Compliant Reconfiguration)	EA	
609	Curb Replacement	LF	110.00
644	Crosswalk 12"	LF	52.00
644	Stop Line	LF	14.00
608	Curb Ramp, Type C (Truncated Dome Replacement)	EA	
617	Aggregate Berm	LF	
SPEC	Full Depth Pavement Repair	SY	

Striping Details

Name of Project: 2019 STREET PROGRAM - ST 1064

Resurfacing Projects

From

Bid Opening:

Spec Item	Description	Unit	QTY Totals	Quantity	Street Name
644	Edge Line, White	MI	1.14	1.10	Morrison Rd
644	Edge Line, Yellow	MI	0.08		Claycraft Rd
644	Lane Line	MI	1.34		Techcenter Dr
644	Center Line	MI	3.20	0.55	
644	Channelizing Line	LF	2,203.00		
644	Stop Line	LF	540.00		
644	Crosswalk 12"	LF	2,190.00		
644	Crosswalk 24"	LF	140.00		
644	Transverse Line, White	LF	495.00		
644	Chevron	LF	33.00		
644	School Symbol Marking	EA	2.00		
644	Lane Arrow	EA	62.00		
644	Word on Pavement, 96"	EA	13.00		
644	Island Marking	SF	60.00		
644	Dotted Line Double Yellow	LF	180.00		
644	Dotted Line, 6"	LF	550.00		

Quantity	Street Name
0.08	Granville St
1.34	Mill St
0.99	Hamilton Rd
1,293.00	
335.00	
1,204.00	
140.00	
95.00	
33.00	
2.00	
28.00	
8.00	
60.00	
180.00	
550.00	

Quantity	Street Name
0.35	Beecher Rd
735.00	
74.00	
257.00	
140.00	
95.00	
12.00	
4.00	

Striping Details

Name of Project: 2019 STREET PROGRAM - ST 1064

Resurfacing Projects

		Street Name	McCutcheon Rd
		From	IR 270 Bridge
		Opening:	Styglar Rd
Spec Item	Description	Unit	Quantity
644	Edge Line, White	MI	0.04
644	Edge Line, Yellow	MI	
644	Lane Line	MI	
644	Center Line	MI	1.31
644	Channelizing Line	LF	175.00
644	Stop Line	LF	131.00
644	Crosswalk 12"	LF	729.00
644	Crosswalk 24"	LF	
644	Transverse Line, White	LF	85.00
644	Chevron	LF	
644	School Symbol Marking	EA	
644	Lane Arrow	EA	22.00
644	Word on Pavement, 96"	EA	1.00
644	Island Marking	SF	
644	Dotted Line Double Yellow	LF	
644	Dotted Line, 6"	LF	

Crack Seal Detail

Name of Project: 2019 STREET PROGRAM - ST 1064

Crack Sealing

Bid Opening:

Spec Item	Description	Unit	Quantity
413	Crack Seal	SY	407.00

Street Name	Haversham Ct N
From	Haversham Dr
	End of Ct

Sycamore Mill Dr	
100 West of Millwood	
Clotts Rd	
Quantity	3,848.00

Picadilly Ct	
Uxbridge Ave	
End of Ct	
Quantity	812.00

Parliament Ave	
Uxbridge Ave	
Theori Ave	
Quantity	1,693.00

Torch Ct	
Uxbridge Ave	
End of Ct	
Quantity	795.00

Dark Star Ave	
Riva Ridge Blvd	
Venetian Way	
Quantity	7,104.00

Ridge Crest (Entire loop)	
Ridge Crest	
Ridge Crest	
Quantity	9,588.00

Crossing Creek Dr	
Deer Meadow Dr	
Trapp Dr	
Quantity	3,908.00

Crack Seal Detail

Name of Project: 2019 STREET PROGRAM - ST 1064

Crack Sealing

Bid Opening:

Street Name	From	To	Quantity	Unit
Eastchester Dr	Eastchester Ct	South End of Ct	2,113.00	SY

Street Name	From	To	Quantity	Unit
Brookhill Dr	Glenhurst Ct	Hightmeadow Dr	5,072.00	

Street Name	From	To	Quantity	Unit
Savern Pl	Havens Corners Rd	End of Ct	2,835.00	

Street Name	From	To	Quantity	Unit
Caro Ln	Caroway Blvd	End of Ct	1,350.00	

Street Name	From	To	Quantity	Unit
Technology Ct	Taylor Station Rd	End of Ct	2,877.00	

Street Name	From	To	Quantity	Unit
Denison Ct	Denison Ave	End of Ct	384.00	

Street Name	From	To	Quantity	Unit
Watling Rd	Styler Rd	Moorfield Dr	2,176.00	

Street Name	From	To	Quantity	Unit
Trabalgis Ct	Watling Rd	End of Ct	1,340.00	

Spec Item	Description	Unit	Quantity
413	Crack Seal	SY	

Crack Seal Detail

Name of Project: 2019 STREET PROGRAM - ST 1064

Crack Sealing

Bid

Opening:

Street Name	From	To	Quantity	Unit
Creighton Ct	Ridenour Rd	End of Ct	1,673.00	SY

Street Name	From	To	Quantity	Unit
McDonnell Pl	Ainsworth Ave	End of Ct	890.00	SY

Street Name	From	To	Quantity	Unit
Windbourne St	Bluestem Ave	Shaker Dr	1,564.00	SY

Street Name	From	To	Quantity	Unit
Crownhill Ct	Lincolnshire Rd	Lincolnshire Rd	2,938.00	SY

Street Name	From	To	Quantity	Unit
N High St	Granville St	Carpenter Rd	6,310.00	SY

Street Name	From	To	Quantity	Unit
N Hamilton Rd	US 62	675 S Stoneridge Ln	96,978.00	SY

Street Name	From	To	Quantity	Unit
Headley Park	Entire Park	Lots, and Driveway	14,590.00	SY

Spec Item	Description	Unit	Quantity
413	Crack Seal	SY	

Sidewalk Detail

2019 STREET PROGRAM - ST 1064		Street Name		Rathburn Park
Curb Ramp and Bike Path		From		Howland
				Cloverly
Spec Item	Description	Unit	QTY Total	Quantity
608	5' Concrete Walk	SF	4510.00	4,510.00



CITY OF GAHANNA

200 S. Hamilton Road
Gahanna, Ohio 43230

Phone: (614) 342-4000
Fax: (614) 342-4100
www.gahanna.gov

Douglas Dr, Flintwood Dr, Nob Hill Ct, Nob Hill Dr, Lancewood Dr,
Jahn Dr, Cotswold Pl, Headley Parking Lot

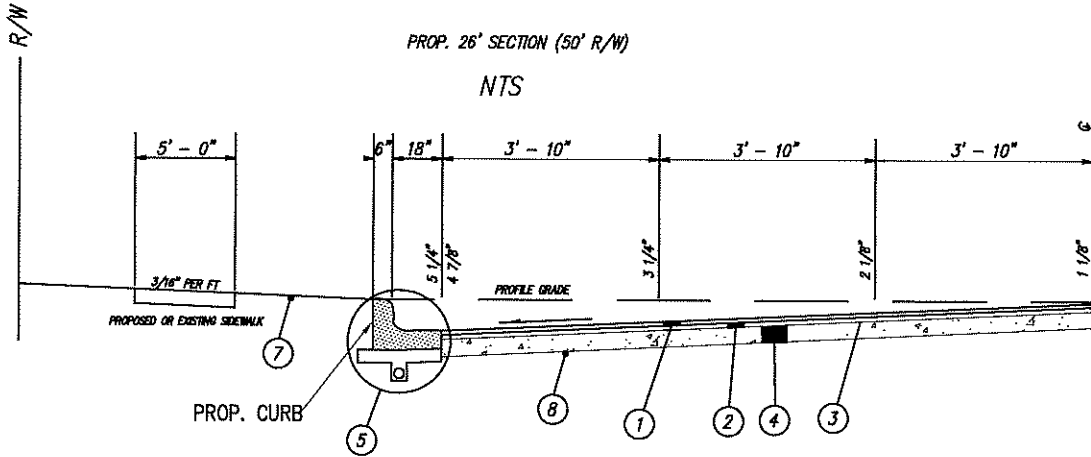

LEGEND

- ① 1-1/2" ASPHALT SURFACE COURSE, ITEM 448
- ② 1-1/2" ASPHALT INTERMEDIATE COURSE, ITEM 448
- ③ TACK COAT, ITEM 407 (APPLIED AT A RATE OF 0.1 GAL/SY)
- ④ 7" PORTLAND CEMENT CONCRETE BASE, ITEM 306
- ⑤ CONCRETE COMBINED CURB AND GUTTER INC. 4" UNDERDRAIN, ITEM 609 (SEE DETAIL)
- ⑥ 7" BITUMINOUS AGGREGATE BASE, ITEM 301 (APPLIED IN TWO 3-1/2" LIFTS)
- ⑦ TOPSOIL, SEEDING AND MULCHING, ITEM 653 & 659
- ⑧ 12" CEMENT BASE STABILIZATION, SPEC

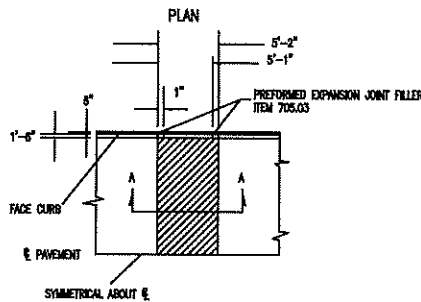

EXPANSION JOINT
NTS

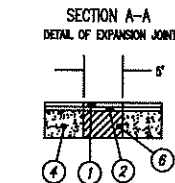

EXPANSION JOINTS SHALL BE CONSTRUCTED WHERE SHOWN ON THE PLANS.
PAYMENT FOR THIS WORK WILL BE MADE AT THE UNIT BID PRICE PER ASPHALT EXPANSION JOINT.

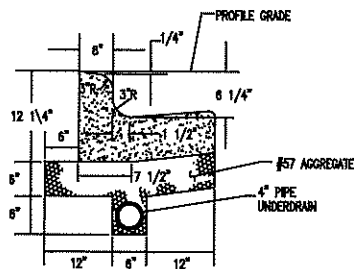

COMBINATION CURB & GUTTER INC. 4" UNDERDRAIN
NTS

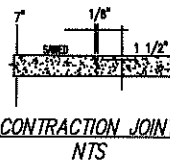

CONTRACTION JOINT
NTS

MAXIMUM SPACING OF SAWED JOINTS SHALL BE 20'
PAYMENT FOR THIS ITEM SHALL BE INCLUDED IN THE PRICE BID FOR ITEM 306, 7" CONCRETE BASE

Note: The contraction joint shall include the application of a self-adhering waterproofing membrane over the contraction joint immediately prior to surfacing. The membrane shall consist of a composite geotextile and rubberized asphalt material. The membrane shall extend over either side of the joint a minimum of six inches.

CITY OF GAHANNA/FRANKLIN COUNTY, OHIO

RECONSTRUCTION

Douglas Dr, Flintwood Dr, Nob Hill Ct, Nob Hill Dr,
Lancewood Dr, Jahn Dr, Cotswold Pl, Headley Parking
Lot

Project No.: **ST-1064**

Date: **02/28/19**

Scale: **NONE**

Drawn By: **DGC**

Checked By:

1

2019 Street Program ST-1064



200 S Hamilton Rd | Gahanna, OH 43230 | 614-342-4005 | www.gahanna.gov

REBUILD

- Douglas Dr (Gary Lee Dr to John Dr)
- Flintwood Dr (McCutcheon Rd to Baywood Dr)
- Nob Hill Ct S (Cherrybottom Rd to Nob Hill Dr S)
- Nob Hill Ct N (Nob Hill Dr S to End of Ct)
- Nob Hill Dr S (Nob Hill Ct to Nob Hill Dr W)
- Lancewood Dr (Denwood Dr N to McCutcheon Rd)
- John Dr (Granville St to John Ct)
- John Dr (John Ct to Gary Lee Dr)
- Cotswold Pl (Moorfield Dr to End of Ct)
- Headley Parking Lot (Entire Lot)

OVERLAY

- Rice Ave (Taylor Rd to Howland Dr)
- Helmbright Dr (Trifecta Ct to Leafcock Ct)
- Caroway Blvd (Farm Creek Dr to Cloverly Dr)
- Uxbridge Av (Clark St Rd to Pleadilly Ct)
- Riva Ridge Blvd (Sugar Hill Pl to Woodtown Dr)
- Beecher Rd (N Hamilton Rd to Ridge Crest Dr)
- Cannomade Ct (Arco Dr to End of Court)
- Highmeadow Dr (Ashburnham Dr to Brookhill Dr/Greencroft Rd)
- Brookhill Dr (Cherry Bottom Rd to Glenhurst Ct)
- Lindenhaven Rd (Lindenhaven Ct to Woodmark Run)
- Imperial Dr (Baroness Wy to Prince of Wales Dr)
- S. High St (Clark St to Granville St)
- Antcliff Ct (Moorfield Dr to End of Ct)
- Olde Ridenour Rd (Stonigate Circle to Carlin Ct E)
- Morrison Rd (Claycraft Rd to Techcenter Dr)
- McCutcheon Rd (Styler Rd to Corp Limit)
- S. Hamilton Rd -- Seam Repairs Only (Techcenter Dr to IR270 Ramp)
- Monison Rd -- Curb and Base Repairs Only (Taylor Rd to Hamilton Rd)
- Goshen Ln -- Base Repairs Only (Hermitage St to W. Johnstown)
- Taylor Station -- Base Repairs Only (Research Rd to Taylor Rd)

CRACK SEAL

- Milan Dr (Andalus Dr to Heil Dr)
- Invicata Pl (Andalus Dr to Colony Pl)
- Colony Pl (Invicata Pl to End of Ct)
- Rivers End Rd (Rocky Fork Dr to Rocky Fork Dr)
- Allanby Ct (Hamilton Rd to End of Ct)
- Sledway Ct (Whickham Way to End of Ct)
- Haversham Ct S (Whickham Way to End of Ct)
- Haversham Ct N (Haversham Dr to End of Ct)
- Sycamore Mill Dr (Millwood Ct to Clotis Rd)
- Pleasidly Ct (Uxbridge Ave to End of Ct)
- Parliament Ave (Uxbridge Ave to Theont Ave)
- Torch Ct (Uxbridge Ave to End of Ct)
- Dark Star Ave (Riva Ridge Blvd to Venetian Way)
- Ridge Crest Dr (Ridge Crest to Ridge Crest)
- Crossing Creek Dr (Deer Meadow Dr to Trapp Dr)
- Eastchester Dr (Eastchester Ct to S End of Ct)
- Brookhill Dr (Glenhurst Ct to Highmeadow Dr)
- Savem Pl (Havens Corners Rd to End of Ct)
- Caro Ln (Caroway Blvd to End of Ct)
- Technology Ct (Taylor Station Rd to End of Ct)
- Denison Ct (Denison Ave to End of Ct)
- Waiting Rd (Styler Rd to Moorfield Dr)
- Trafalgar Ct (Waiting Rd to End of Ct)
- Creighton Ct (Ridenour Rd to End of Ct)
- McDonnell Pl (Ainsworth Ave to End of Ct)
- Windbourne St (Bluestem Ave to Shaker Dr)
- Crownhill Ct (Lincolnshire Rd to Lincolnshire Rd)
- N. High St (Granville St to Carpenter Rd)
- N Hamilton Rd (US62 to Stoneridge Ln)

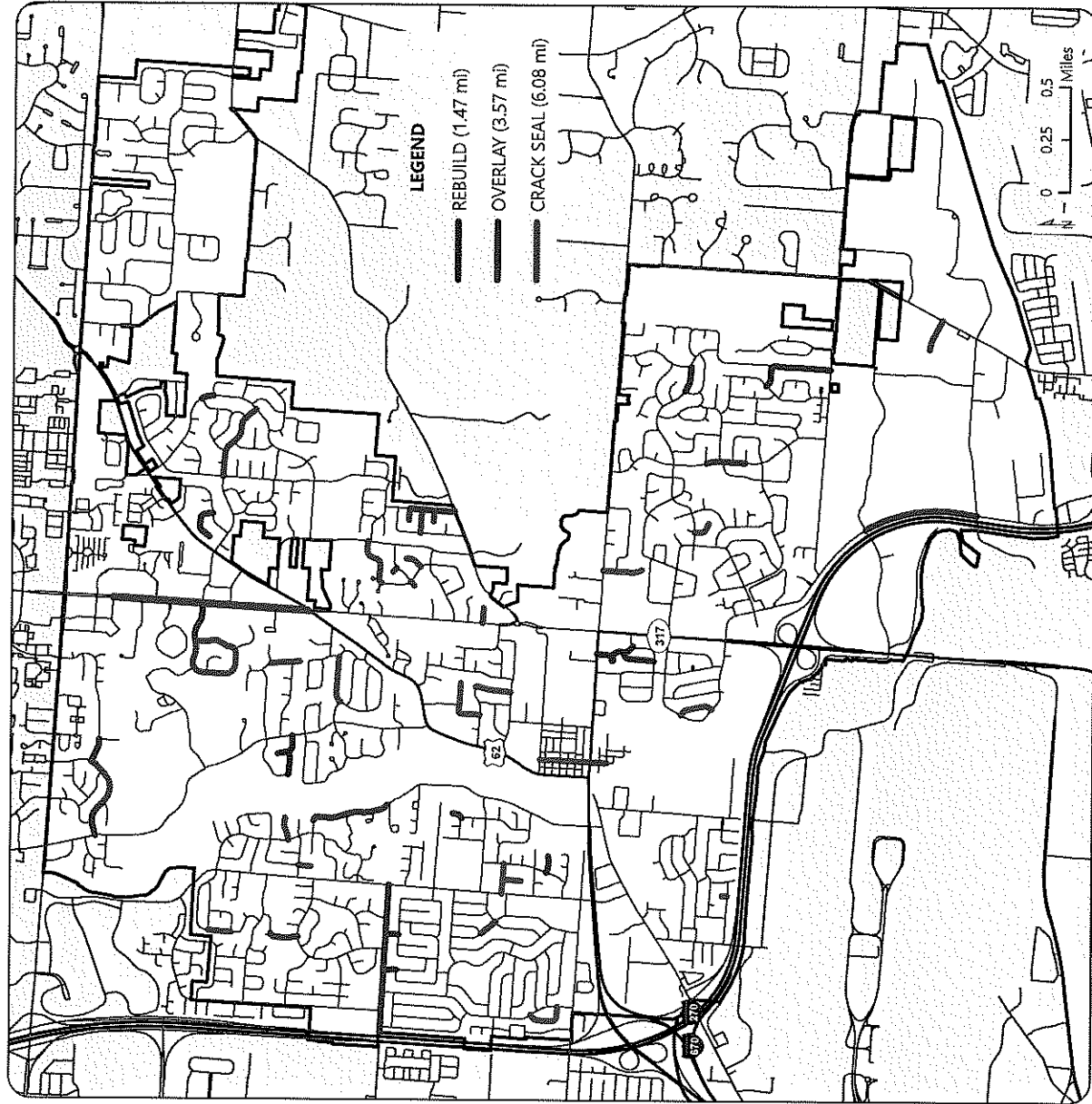

NOTE: This map is a resource to be used for general information purposes only. The City of Gahanna shall assume no liability for any errors, omissions, or inaccuracies in the information provided. All GIS data layers are referenced in the Ohio State Plane Coordinate System, Horizontal - North American Datum (NAD) 83 (95) Vertical - North American Datum (NAD) 83. Units - Surveyors Feet. All data has been developed from public records that are constantly undergoing change and is not warranted for content, completeness, or accuracy. The City of Gahanna does not warrant, guarantee or represent the data to be fit for a particular use or purpose.

S:\Project_Efiles\YearlyStreetPrograms\2019\Mapa\StreetProgram-2019.mxd

Created: 03/05/2019